

Product Specification

Model Name	S043QWQ26HG-DC06
Description	Standard LCD Module 4.3" WQVGA 480(RGB)x272 Dots
Date	2017/4/22
Version	1.0

Approved by/Date	Check by/Date	Prepared by/Date
Sam 2017/4/22	Borger 2017/4/22	Jack Guo 2017/4/22

Customer Approval	
Date	

Table of Contents

1. Record of Revision	3
2. General Specifications	4
3. Input/Output Terminals	5
4. Absolute Maximum Rating	6
5. Electrical Characteristics	6
6. Interface Timing	8
7. Optical Characteristics	13
8. Environmental / Reliability Tests	17
9. Mechanical Drawing	18
10. Packing	19
11. Precautions for Use of LCD modules	20

2. General Specifications

Feature		Spec
Characteristics	Size	4.3 inch
	Resolution	480(horizontal)*272(Vertical)
	Interface	RGB-24bit
	Connect type	Connector
	Technology type	a-Si
	Pixel pitch (mm)	0.198 x 0.198
	Pixel Configuration	R.G.B.-Stripe
	Display Mode	Normally White
	Driver IC	ILI6480
	CTP Driver IC	FT5306
	Viewing Direction	12 O'clock
Mechanical	LCM (W x H x D) (mm)	105.5*67.2*4.36
	Active Area(mm)	95.04 x 53.86
	With/Without TSP	With CTP
	Weight (g)	TBD
	LED Numbers	10 LEDs

Note 1: Requirements on Environmental Protection: RoHs

Note 2: LCM weight tolerance: +/- 5%

3. Input/OutputTerminals

LCD PIN-MAP

No	Symbol	Description
1	VBL-	Backlight LED Cathode
2	VBL+	Backlight LED Anode
3	GND	System Ground
4	VDD	Power supply for logic operation
5~12	R0~R7	Data bus
13~20	G0~G7	Data bus
21~28	B0~B7	Data bus
29	GND	System Ground
30	DCLK	Pixel clock signal
31	DISP	Display on/off control
32	HSYNC	Horizontal Sync signal
33	VSYNC	Vrtical Sync signal
34	DE	Data Enable
35	NC	No connect
36	GND	System Ground
37	XR	The right side signal of TP
38	YD	The down side signal of TP
39	XL	The left side signal of TP
40	YU	The up side signal of TP

CTP PIN-MAP

Pin	Signal	Description
1	VSS	Ground
2	VDD	Power supply for CTP
3	SCL	I2C clock input
4	NC	-
5	SDA	I2C data input and output
6	NC	-
7	RST	Reset Pin for CTP
8	WAKE	External interrupt from the host.
9	INT	Interrupt request to the host
10	VSS	Ground

4. Absolute Maximum Rating

Item	Symbol	MIN	Typ	MAX	Unit	Remark
Supply Voltage	VDD	-0.5	-	5.0	V	-
Operating Temperature	TOPR	-20	-	70	°C	-
Storage Temperature	TSTG	-30	-	80	°C	-

5. Electrical Characteristics

5.1 Driving TFT LCD Panel

Item	Symbol	MIN	TYP	MAX	Unit	Remark
Supply Voltage	V _{DD}	3.0	3.3	3.6	V	
Input Signal Voltage	Low Level	V _{IL}	GND	-	0.3x VDD	V
	High Level	V _{IH}	0.7x VDD	-	VDD	V
Output Signal Voltage	Low Level	V _{OL}	GND	-	VDD+0.4	V
	High Level	V _{OH}	VDD-0.4	-	-	V

5.2 CTP Electrical Characteristics

FPC Design	Item	Description	Remark
COF	IC solution on TP Model	FT5306	
	Touch Count Max	5 point	
	Display Resolution	480*272	
	Interface Type	I2C	
	I2C Slave Address	OX70	
	Origin of Coordinate	Top left corner	

5.3 LED Driving Conditions

Item	Symbol	MIN	TYP	MAX	Unit	Remark
Forward Current	I _F	-	40	-	mA	
Forward Voltage	V _F	15	16	17	V	
Backlight Power consumption	W _{BL}	-	0.64	-	W	
LED Lifetime		25000	-	-	Hrs	

Note 1: Each LED: I_F =20 mA, V_F =3.2+/-0.2V.

Note 2: Optical performance should be evaluated at Ta=25°C only.

Note 3: If LED is driven by high current, high ambient temperature & humidity condition. The life Time of LED will be reduced. Operating life means brightness goes down to 50% initial brightness. Typical operating life time is estimated data.

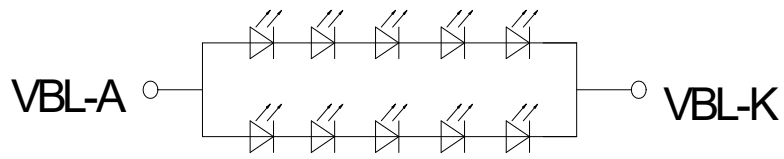
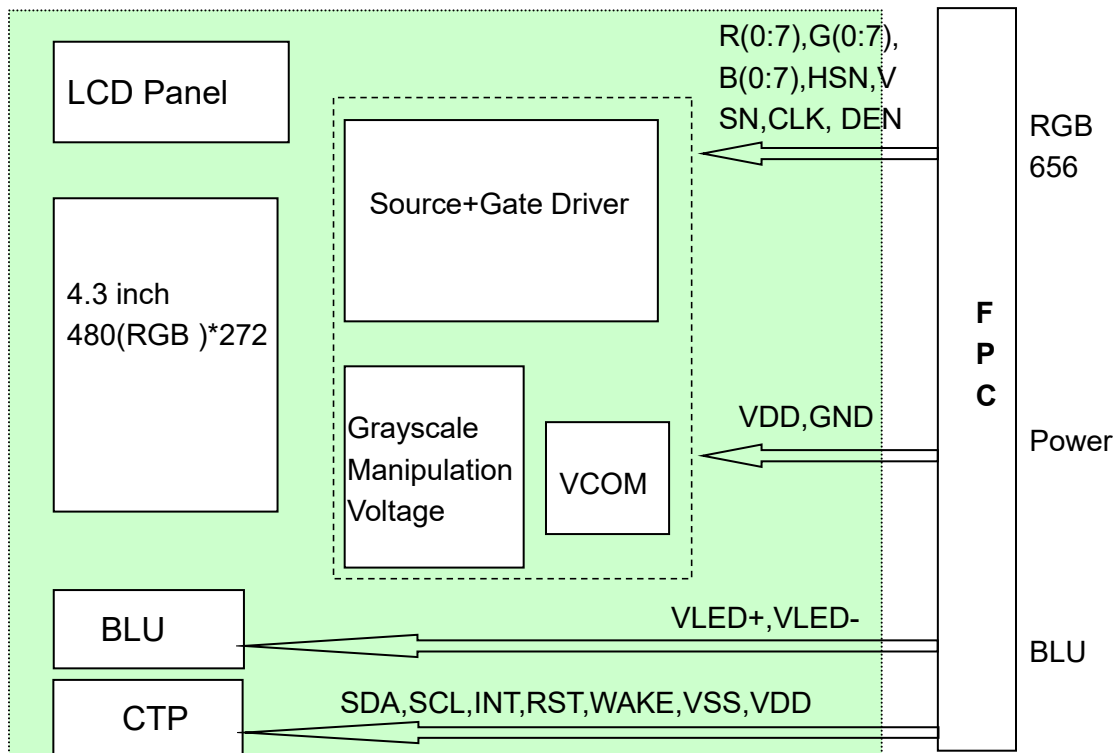

Figure: LED connection of backlight(Constant Current)

5.4 Block Diagram



6.3 Parallel RGB Data Format

Parallel RGB Mode Data format

(HV Mode)

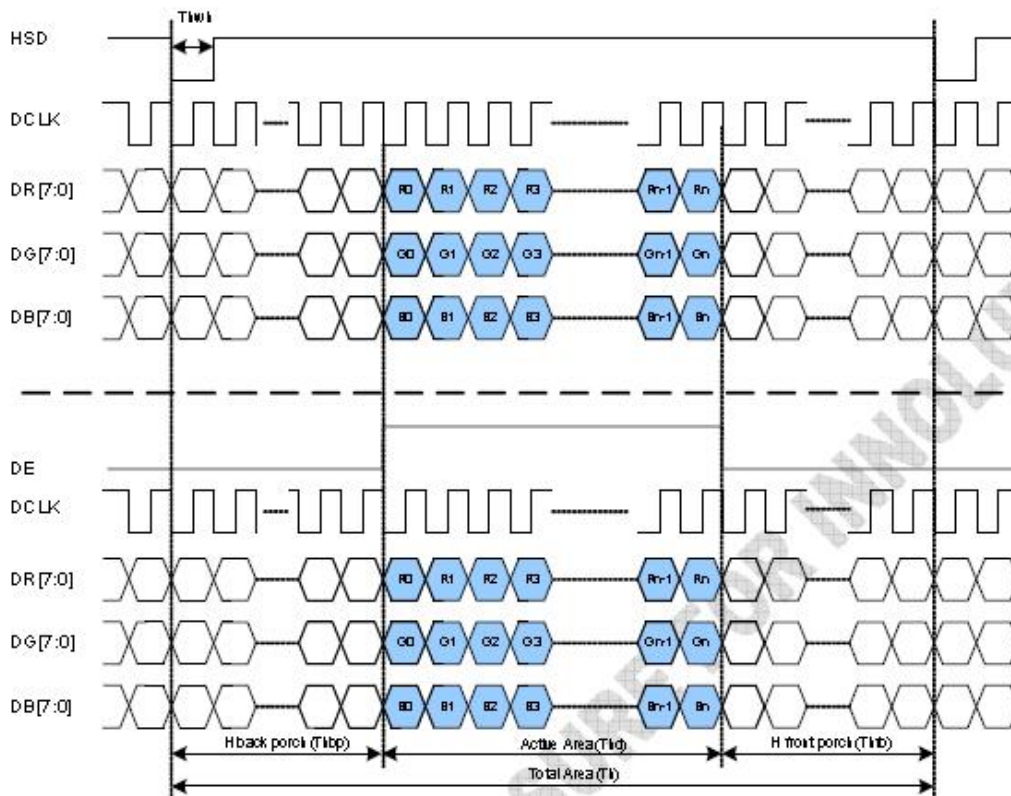

Parallel RGB input timign table

Parameter	Symbol	Value			Unit
		Min.	Typ.	Max.	
DCLK frequency	fclk	5	9	12	MHz
VSD period time	Tv	277	288	400	H
VSD display area	Tvd	272			H
VSD back porch	Tvb	3	8	31	H
VSD front porch	Tvfp	2	8	97	H
HSD period time	Th	520	525	800	DCLK
HSD display area	Thd	480			DCLK
HSD back porch	Thbp	36	40	255	DCLK
HSD front porch	Thfp	4	5	65	DCLK

Serial RGB input timing table

Parameter	Symbol	Value			Unit
		Min.	Typ.	Max.	
DCLK frequency	fdclk	-	27	-	MHz
VSD period time	Tv	277	288	400	H
VSD display area	Tvd	272			H
VSD back porch	Tvb	3	8	31	H
VSD front porch	Tvfp	2	8	97	H
HSD period time	Th	-	1728	-	DCLK
HSD display area	Thd	1440			DCLK
HSD back porch	Thbp	-	120	-	DCLK
HSD front porch	Thfp	-	168	-	DCLK

6.4 3-wire Timing Diagram

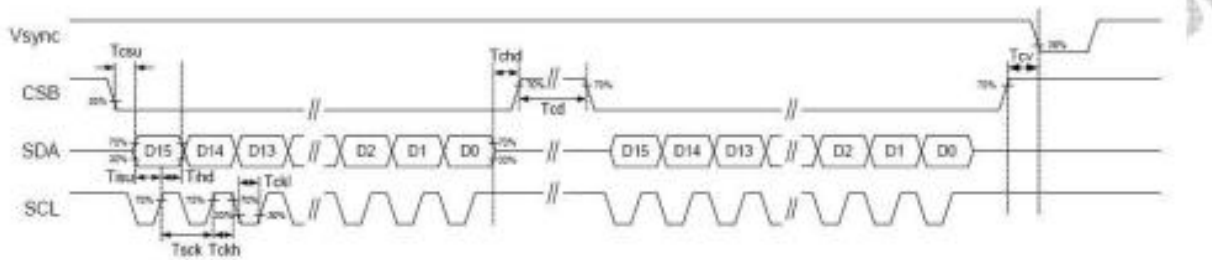

6.5 Output Timing Diagram

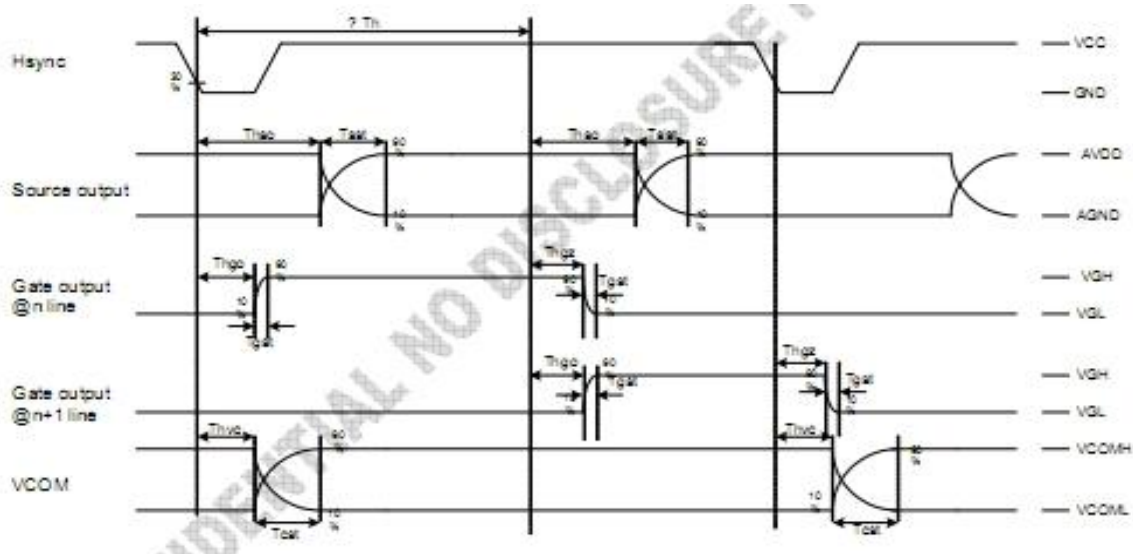

6.6 Capacitive touch panel Specification

I2C

The I2C is always configured in the Slave mode. The data transfer format is shown in [Figure 2-4](#).

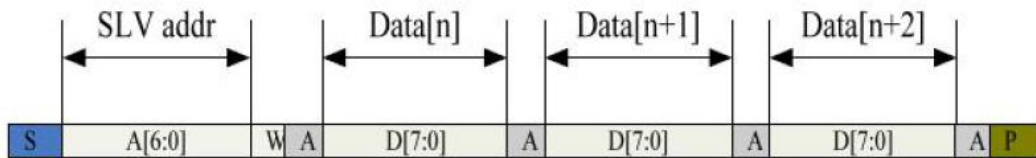
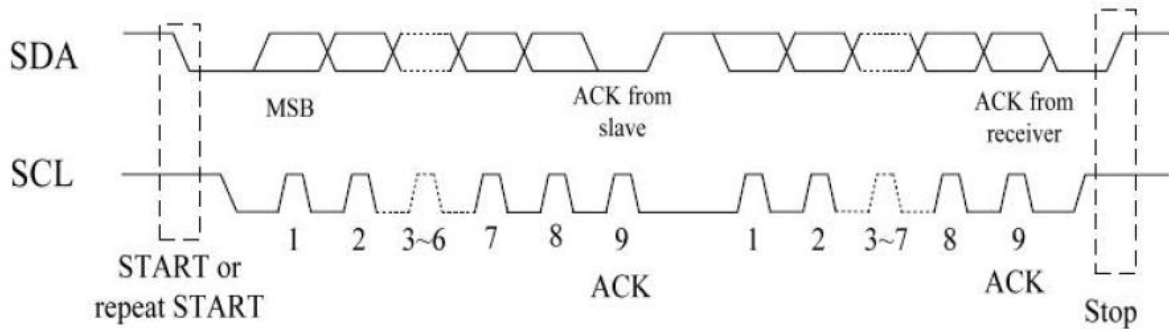

Figure 2-5 I2C master write, slave read

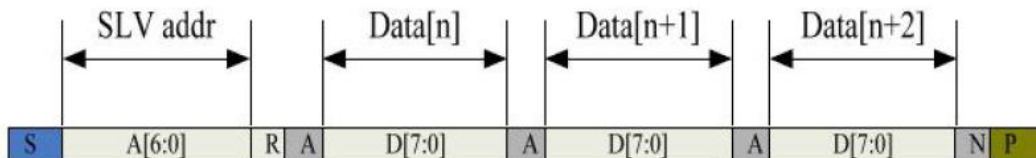

Figure 2-6 I2C master read, slave write

Table 2-1 lists the meanings of the mnemonics used in the above figures.

Table 2-1 Mnemonics Description

Mnemonics	Description
S	I2C Start or I2C Restart
A[6:0]	Slave address A[6:4]: 3'b011 A[3:0]: data bits are identical to those of I2CCON[7:4] register.
W	1'b0: Write
R	1'b1: Read
A(N)	ACK(NACK)
P	STOP: the indication of the end of a packet (if this bit is missing, S will indicate the end of the current packet and the beginning of the next packet)

I2C Interface Timing Characteristics is shown in Table 2-2.

Table 2-2 I2C Timing Characteristics

Parameter	Unit	Min	Max
SCL frequency	KHz	0	400
Bus free time between a STOP and START condition	us	4.7	\
Hold time (repeated) START condition	us	4.0	\
Data setup time	ns	250	\
Setup time for a repeated START condition	us	4.7	\
Setup Time for STOP condition	us	4.0	\

7. Optical Characteristics

Items		Symbol	Condition	Min.	Typ.	Max.	Unit	Remark	Note
Response time		Tr+Tf	-	-	25	50	ms	FIG.1	Note4
Contrast Ratio		CR		400	500	-	-	FIG.2	Note1
Surface luminance		LV	$\theta = 0^\circ$	360	400	-	cd/m2	FIG.2	Note2
Luminance uniformity		Yu	$\theta = 0^\circ$	75	80	-	%	FIG.2	Note3
NTSC		-	$\theta = 0^\circ$	-	50	-	%	FIG.2	Note5
Viewing angle		θ_T	Center CR \geq 10	40	50	-	deg	FIG.3	Note6
		θ_B		60	70	-	deg	FIG.3	
		θ_L		60	70	-	deg	FIG.3	
		θ_R		60	70	-	deg	FIG.3	
Chromaticity	Red	R _X	$\theta = 0^\circ$ $\varnothing = 0^\circ$ Ta=25°	TBD	TBD	TBD	-	FIG.2 CIE1931	Note5
		R _Y		TBD	TBD	TBD	-		
	Green	G _X		TBD	TBD	TBD	-		
		G _Y		TBD	TBD	TBD	-		
	Blue	B _X		TBD	TBD	TBD	-		
		B _Y		TBD	TBD	TBD	-		
	White	W _X		TBD	TBD	TBD	-		
		W _Y		TBD	TBD	TBD	-		

Note1. Definition of contrast ratio

Contrast ratio(Cr) is defined mathematically by the following formula.

For more information see FIG.2.

Contrast ratio= $\frac{\text{Luminance measured when LCD on the "White" state}}{\text{Luminance measured when LCD on the "Black" state}}$

For contrast ratio, Surface Luminance, Luminance uniformity and CIE,the testing data is base on TOPCON's BM-5 or BM-7 photo detector or compatible.

Note2. Definition of surface luminance

Surface luminance is the luminance with all pixels displaying white. For more information see FIG.2.

L_v = Average Surface Luminance with all white pixels(P1,P2,P3,Pn)

Note3. Definition of luminance uniformity

The luminance uniformity in surface luminance is determined by measuring luminance at each test position 1 through n, and then dividing the maximum luminance of n points luminance by minimum luminance of n points luminance.For more information see FIG.2.

$Y_u = \frac{\text{Minimum surface luminance with all white pixels (P1,P2,P3,.....,Pn)}}{\text{Maximum surface luminance with all white pixels (P1,P2,P3,.....,Pn)}}$

Note4. Definition of response time

The response time is defined as the LCD optical switching time interval between "White" state and "Black"state.Rise time (T_r) is the time between photo detector output intensity changed from 90% to 10%. And fall time (T_f) is the time between photo detector output intensity changed from 10% to 90%.

For additional information see FIG1.

Note5. Definition of color chromaticity (CIE1931)

CIE (x,y) chromaticity,The x,y value is determined by screen active area center position P5.For more information see FIG.2.

Note6. Definition of viewing angle

Viewing angle is the angle at which the contrast ratio is greater than 10. Angles are determined for the horizontal or x axis and the vertical or y axis with respect to the z axis which is normal to the LCD surface.

For more information see FIG.3.

For viewing angle and response time testing, the testing data is base on Autronic-Melchers's ConoScope or DMS series Instruments or compatible.

FIG.1. The definition of response Time

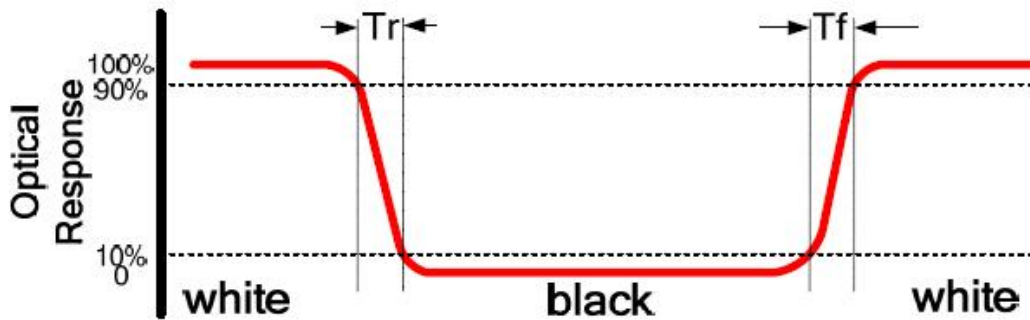

FIG.2. Measuring method for contrast ratio, surface luminance, luminance uniformity, CIE (x,y) chromaticity

Size : $S \leq 5"$ (see Figure a)

A : 5 mm B : 5 mm

H, V : Active area

Light spot size $\varnothing = 5\text{mm}$ (BM-5) or $\varnothing = 7.7\text{mm}$ (BM-7) 50cm distance or compatible distance from the LCD surface to detector lens.

test spot position : see Figure a.

measurement instrument : TOPCON's luminance meter BM-5 or BM-7 or compatible (see Figure c).

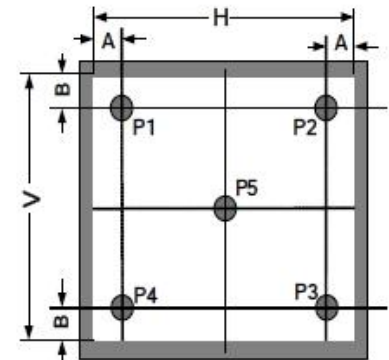

Figure a

Size : $5" < S \leq 12.3"$ (see Figure b)

H, V : Active area

Light spot size $\varnothing = 5\text{mm}$ (BM-5) or $\varnothing = 7.7\text{mm}$ (BM-7) 50cm distance or compatible distance from the LCD surface to detector lens.

test spot position : see Figure b.

measurement instrument : TOPCON's luminance meter BM-5 or BM-7 or compatible (see Figure c).

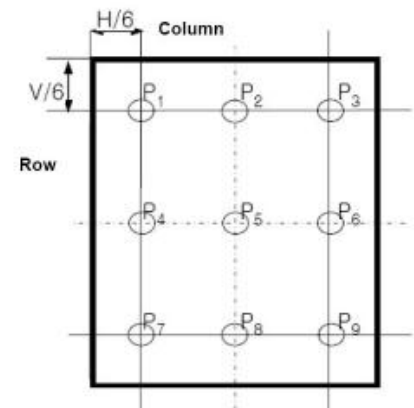

Figure b

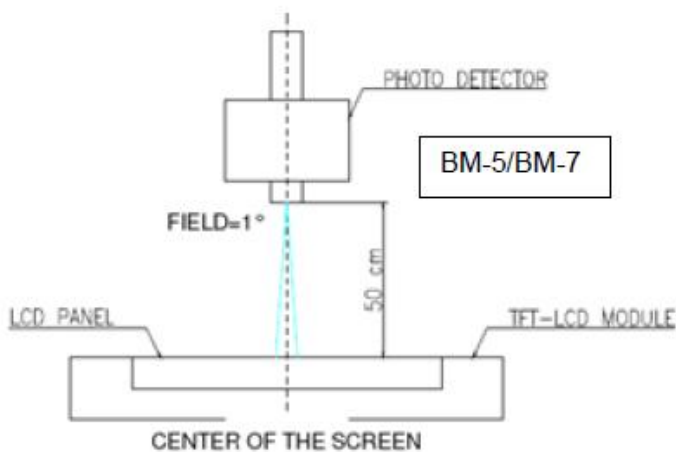
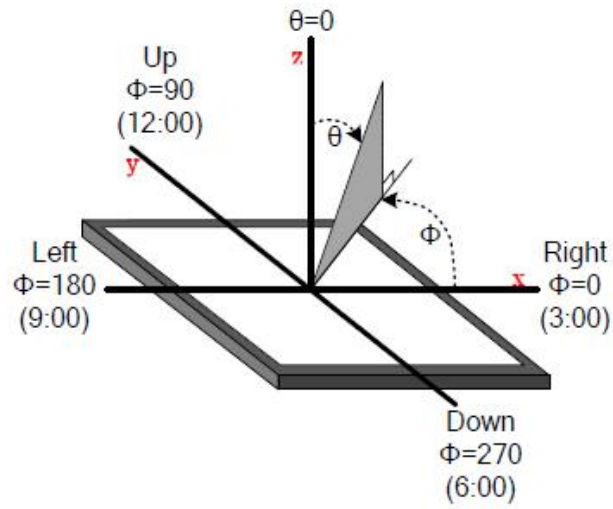

Figure c

FIG.3. The definition of viewing angle



8. Environmental / Reliability Tests

No	Test Item	Condition	Remarks
1	High Temperature Operation	T _s = +70°C, 96hrs	Note 1 IEC60068-2-2, GB2423. 2-89
2	Low Temperature Operation	T _a = -20°C, 96hrs	Note 2 IEC60068-2-1 GB2423.1-89
3	High Temperature Storage	T _a = +80°C, 120hrs	IEC60068-2-2 GB2423. 2-89
4	Low Temperature Storage	T _a = -30°C, 120hrs	IEC60068-2-1 GB/T2423.1-89
5	High Temperature & Humidity Storage	T _a = +60°C, 90% RH max, 120 hours	IEC60068-2-3 GB/T2423.3-2006
6	Thermal Shock (Non-operation)	-20°C 30 min ~ +60°C 30 min Change time: 5min, 30 Cycle	Start with cold temperature, end with high temperature IEC60068-2-14, GB2423.22-87
7	Electro Discharge (Operation)	Static C=150pF, R=330 Ω, 5 points/panel Air:±8KV, 5 times; Contact: ±4KV, 5 times; (Environment: 15°C ~ 35°C, 30% ~ 60%, 86Kpa ~ 106Kpa)	IEC61000-4-2 GB/T17626.2-1998
8	Vibration (Non-operation)	Frequency range: 10~55Hz, Stroke: 1.mm Sweep: 10Hz~55Hz~10Hz 2 hours for each direction of X .Y. Z. (package condition)	IEC60068-2-6 GB/T2423.5-1995
9	Shock (Non-operation)	60G 6ms, ± X, ±Y , ± Z 3 times for each direction	IEC60068-2-27 GB/T2423.5-1995
10	Package Drop Test	Height: 80 cm, 1 corner, 3 edges, 6 surfaces	IEC60068-2-32 GB/T2423.8-1995

Note: 1. T_s is the temperature of panel's surface.

2. T_a is the ambient temperature of sample.

3. The size of sample is 5pcs.

10. Packing

Packing Method

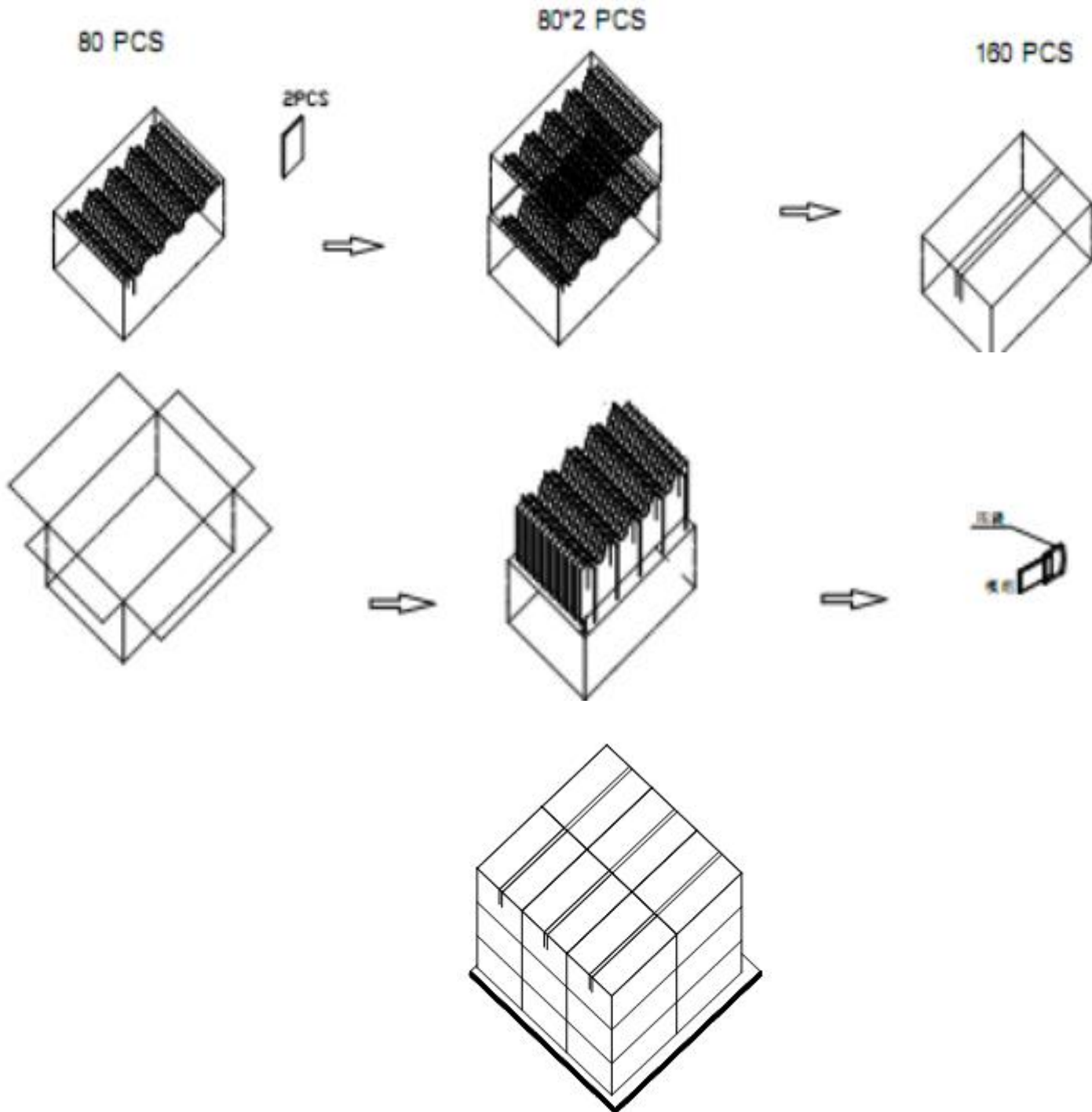

11. Precautions for Use of LCD modules

11.1 Handling Precautions

11.1.1. The display panel is made of glass. Do not subject it to a mechanical shock by dropping it from a high place, etc.

11.1.2. If the display panel is damaged and the liquid crystal substance inside it leaks out, be sure not to get any in your mouth, if the substance comes into contact with your skin or clothes, promptly wash it off using soap and water.

11.1.3. Do not apply excessive force to the display surface or the adjoining areas since this may cause the color tone to vary.

11.1.4. The polarizer covering the display surface of the LCD module is soft and easily scratched. Handle this polarizer carefully.

11.1.5. If the display surface is contaminated, breathe on the surface and gently wipe it with a soft dry cloth. If still not completely clear, moisten cloth with one of the following solvents:

- Isopropyl alcohol
- Ethyl alcohol

Solvents other than those mentioned above may damage the polarizer. Especially, do not use the following:

- Water
- Ketene
- Aromatic solvents

11.1.6. Do not attempt to disassemble the LCD Module.

11.1.7. If the logic circuit power is off, do not apply the input signals.

11.1.8. To prevent destruction of the elements by static electricity, be careful to maintain an optimum work environment.

11.1.8.1. Be sure to ground the body when handling the LCD Modules.

11.1.8.2. Tools required for assembly, such as soldering irons, must be properly ground.

11.1.8.3. To reduce the amount of static electricity generated, do not conduct assembly and other work under dry conditions.

11.1.8.4. The LCD Module is coated with a film to protect the display surface. Be care when peeling off this protective film since static electricity may be generated.

11.2 Storage Precautions

11.2.1. When storing the LCD modules, avoid exposure to direct sunlight or to the light of fluorescent lamps.

11.2.2. The LCD modules should be stored under the storage temperature range. If the LCD modules will be stored for a long time, the recommend condition is:

Temperature : 0°C ~ 40°C Relatively humidity: ≤80%

11.2.3. The LCD modules should be stored in the room without acid, alkali and harmful gas.

11.3 Transportation Precautions

The LCD modules should be no falling and violent shocking during transportation, and also should avoid excessive press, water, damp and sunshine.