



PRODUCT SPECIFICATION

CDTECH Model: **S070HWX133HN-FC102**

CUSTOMER Model: **-**

Description: **7.0" TFT-LCD Module with CTP**

Version: **1.0**

CDTECH	PREPARED BY	CHECKED BY	APPROVED BY
SIGNATURE			
DATE	2023.1.10	2023.1.10	2023.1.10

CUSTOMER APPROVAL	SIGNATURE	DATE



Contents

1. General Specifications	4
2. Absolute Maximum Ratings	5
3. Electrical Characteristics	5
4. Interface Pin Assignment	7
5. Interface Characteristics	8
6. Optical Specifications	14
7. Reliability Test Items	17
8. Mechanical Drawing	18
9. Packing	19
10. Precautions for Use of LCD modules	20

1. General Specifications

1.1 LCM General Information

Item	Specification	Unit
LCD Size	7.0	inch
Number of Pixels	280 (H) RGB x 1424 (V)	pixels
Display Mode	Normally Black	-
Viewing Direction	Free	o' clock
Interface	MIPI	-
Display Colors	16.7M	colors
Outline Dimension	43.30 (H) x 201.00 (V) x 5.23 (D)	mm
Active Area	33.60 (H) x 170.88 (V)	mm
Pixel Pitch	0.12 (H) x 0.12 (V)	mm
Driver IC	OTA7290B	-
Operation Temperature	-20~70	°C
Storage Temperature	-30~80	°C

1.2 Touch Panel Information

Item	Specification
Touch Structure	G+FF
Bonding Type with LCM	OCA Optical Bonding
Driver IC	FT5446IDQQ
Interface	I ² C
Touch Count Max	5 Points
Surface treatment	-
Surface hardness	6H
I2C slave address	0x70
Origin of coordinate	Left Lower Corner

Note1: Requirements on environmental protection RoHS compliant.

2. Absolute Maximum Ratings

Item	Symbol	MIN.	MAX.	Unit	Note
Analog Supply voltage	VDD	-0.3	5.0	V	Note 1

Note 1: Permanent damage may occur to the LCD module if beyond this specification.

Functional operation should be restricted to the conditions described under normal operating conditions.

3. Electrical Characteristics

3.1 Recommended Operating Condition for TFT LCD

Item	Symbol	Min.	Typ.	Max.	Unit	Note
Analog Supply voltage	VCI	3.0	3.3	3.6	V	
Analog supply current	I _{VCI}	-	TBD	-	mA	VCI=3.3V
Logic input voltage	V _{IH}	0.7*VCI	-	VCI	V	
	V _{IL}	GND	-	0.3*VCI	V	

3.2 Recommended Driving Condition for Backlight

Item	Symbol	Min.	Typ.	Max.	Unit	Note
Driving Current	I _F	-	40	-	mA	
Driving Voltage	V _F	21.6	-	27.2	V	
Power consumption	W _{BL}	0.864	-	1.088	W	
LED Life-Time	N/A	30,000	-	-	Hours	Ta=25°C Note 1

Note 1: LED lifetime is defined as the module brightness decay 50% of original brightness at Ta=25 degree, typical current.

Note 2:LED circuit :

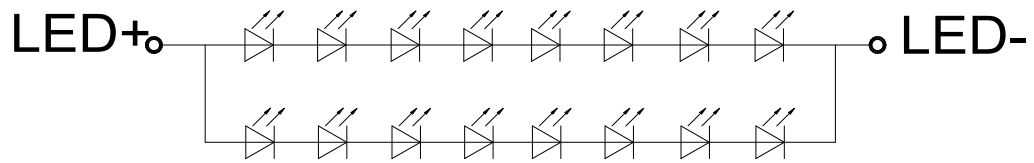

3.3 Touch Panel

Item	Symbol	Min.	Typ.	Max.	Unit	Note
Power Supply voltage	VDD	-	3.3	-	V	
Analog supply current	I_{VDD}	-	TBD	-	mA	VDD=3.3V
Input high-level voltage	V_{IH}	$0.7 \cdot VDD$	-	VDD	V	
Input low -level voltage	V_{IL}	GND	-	$0.3 \cdot VDD$	V	

4. Interface Pin Assignment

4.1 LCM Pin Assignment

Recommended connector: FH12-30S-0.5HS(55) manufactured by HIROSE

No.	Symbol	Description
1	GND	Ground
2	DN3	MIPI Negative data signal(-)
3	DP3	MIPI Positive data signal(+)
4	GND	Ground
5	DN2	MIPI Negative data signal(-)
6	DP2	MIPI Positive data signal(+)
7	GND	Ground
8	CKN	MIPI Negative clock signal(-)
9	CKP	MIPI Positive clock signal(+)
10	GND	Ground
11	DN1	MIPI Negative data signal(-)
12	DP1	MIPI Positive data signal(+)
13	GND	Ground
14	DN0	MIPI Negative data signal(-)
15	DP0	MIPI Positive data signal(+)
16	GND	Ground
17	GND	Ground
18	TE	Sync signal for touch panel
19	RESET	Device reset signal
20	GND	Ground
21-23	VCI	Power supply for logic operation
24	GND	Ground
25-26	NC	No connection
27-28	LEDK	Power for LED backlight (Cathode)
29-30	LEDA	Power for LED backlight (Anode)

4.2 Touch FPC Pin Assignment

No.	Symbol	Description
1	GND	Ground
2	INT	Interrupt signal from CTP
3	RST	Reset pin
4	SDA	I2C data input and output
5	SCL	I2C clock input
6	VDD	Power supply for CTP

5. Interface Characteristics

5.1 Power On/Off Sequence

In order to prevent IC from power on reset fail, the rising time (T_{POR}) of the digital power supply VDD should be maintained within the given specifications. Refer to "AC Characteristics" for more detail on timing.

Power-On/Off Timing Sequence:

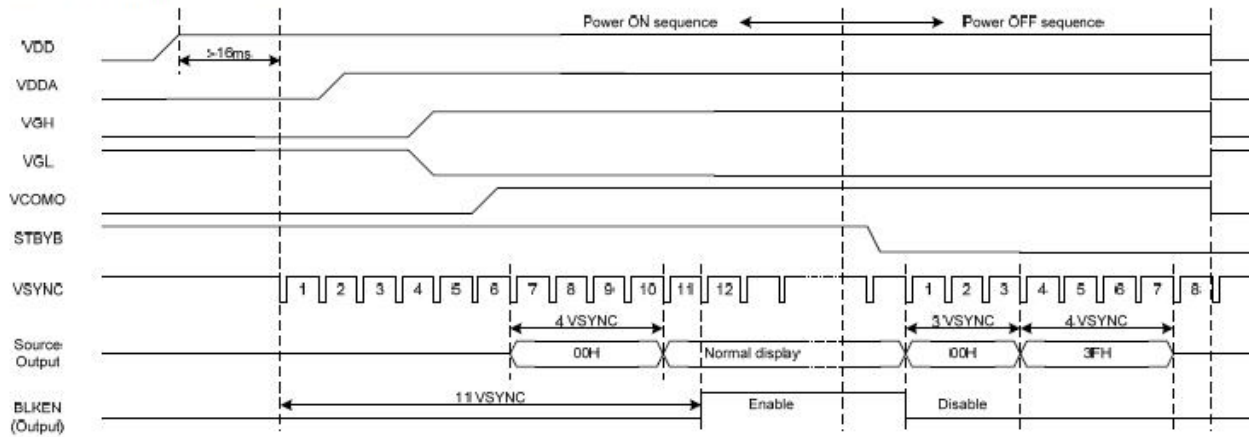

Enter and Exit Standby Mode Sequence:

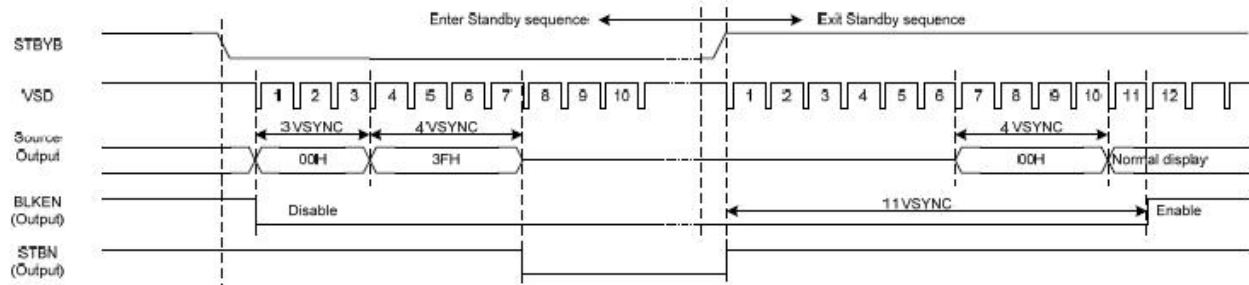

5.2 Reset Timing Characteristics

BIST Timing

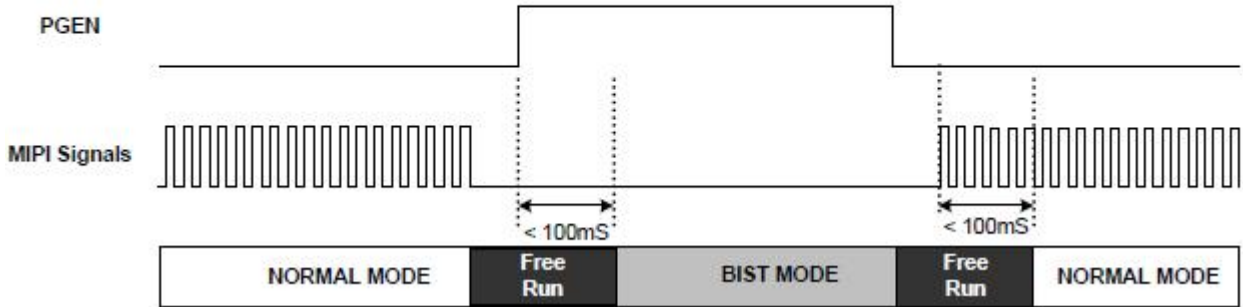
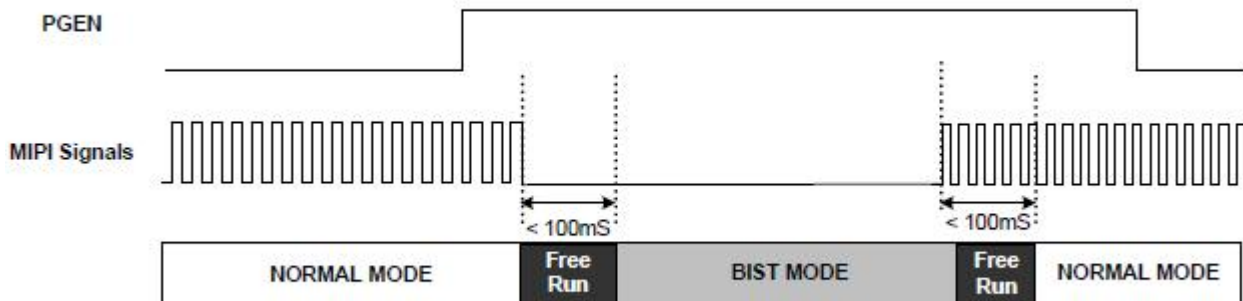

Vertical Timing Diagram HV (Cascade)

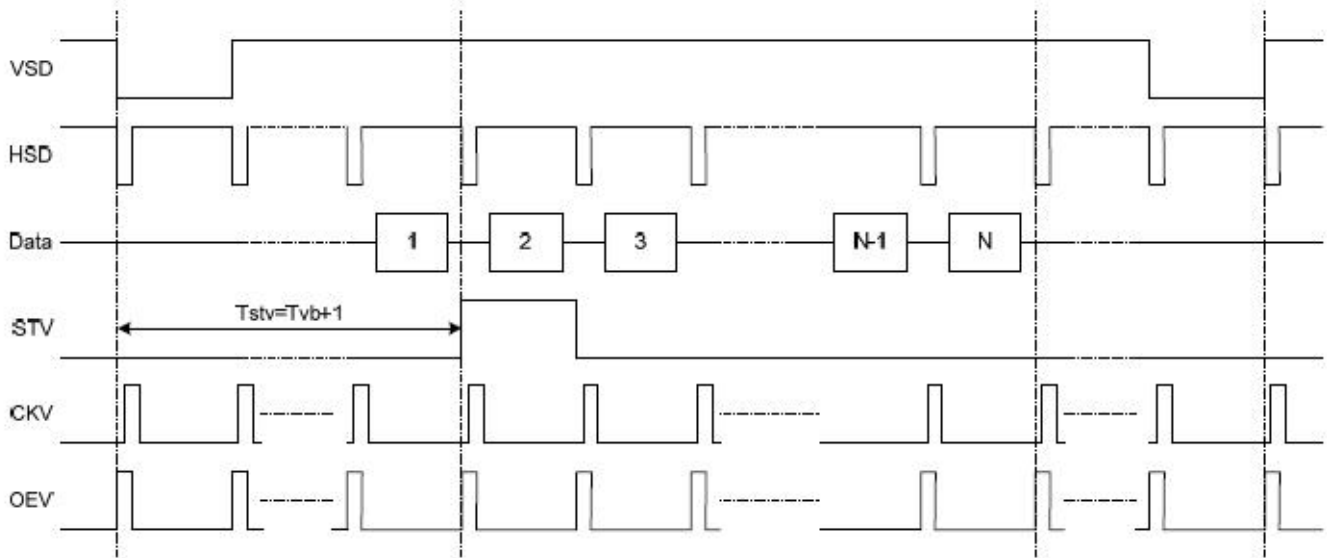

Vertical Timing Diagram DE (Cascade)

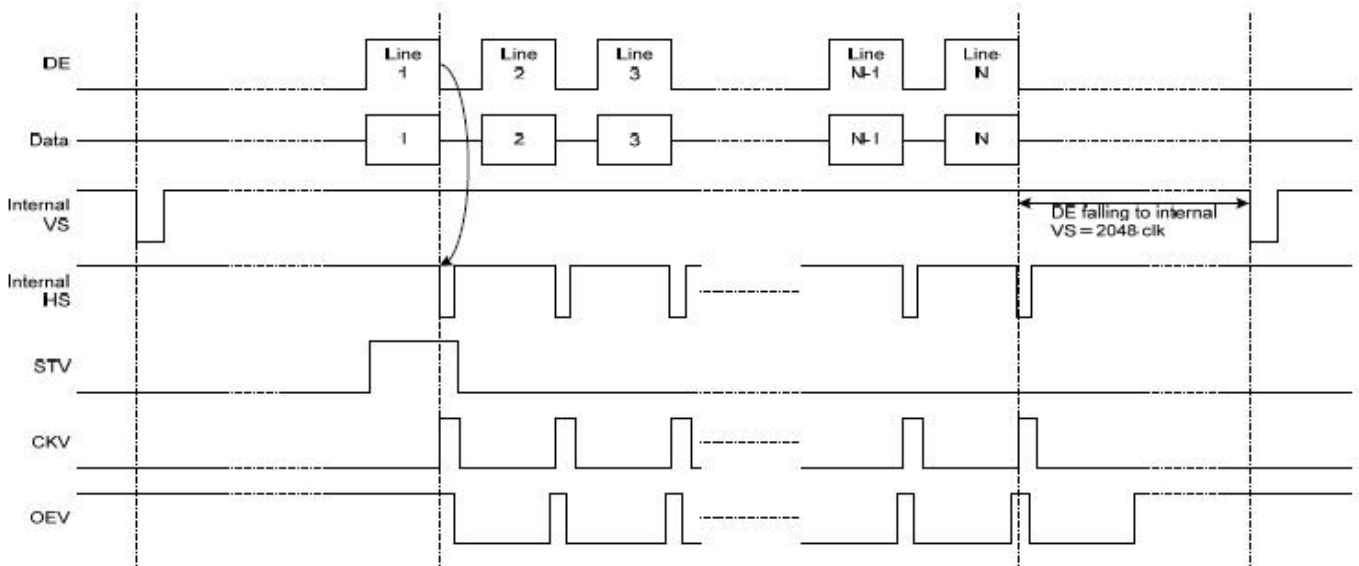

Gate output timing diagram (Cascade)

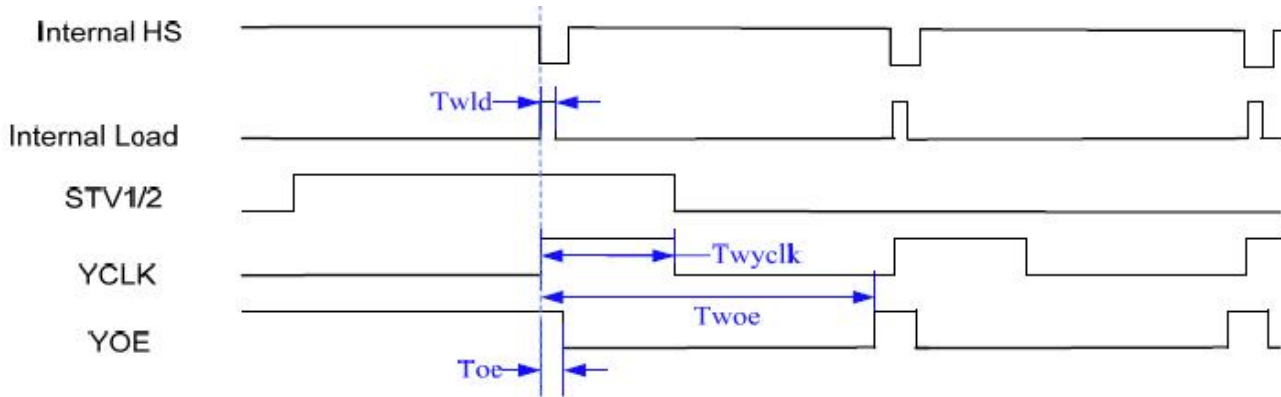

MIPI DC Characteristics

HS Receiver DC Specification

Parameter	Symbol	Rating			Unit	Note
		Min	Typ	Max		
Operation Voltage	VDD	1.5-10%	1.5	1.5+10%	mV	
Differential Input Voltage	VID	70	200	260	mV	
Common Mode Voltage	$V_{CMRX(DC)}$	70	-	330	mV	
Differential Input High Threshold Voltage	VTH	-	-	70	mV	
Differential Input Low Threshold Voltage	VTL	-70	-	-	mV	
Singled-ended input high voltage	V_{IHHS}	-	-	460	mV	
Singled-ended input low voltage	V_{ILHS}	-40	-	-	mV	
Singled-ended threshold for HS termination enable	$V_{TERM-EN}$	-	-	450	mV	
Differential input impedance	Z_{ID}	80	100	125	ohm	
Pin leakage current	I_{LEAK}	-10	-	10	uA	
Common-mode interference beyond 450MHz	$\Delta V_{CMRX(HF)}$	-	-	100	mV	
Common-mode interference 50MHz - 450MHz	$\Delta V_{CMRX(LF)}$	-50	-	50	mV	
Common-mode termination	C_{CM}	-	-	60	pF	
Embedded Termination	R_T	90	100	110	ohm	2bits $RT_SEL[1: 0]$ for termination resistor selection 00 → 200ohm 10 , 01 → 150ohm 11 → 100ohm (default) 1bit $ERMEN_EN$ for termination resistor enable $TERMEN=0$, termr disable $R=(OPEN)$ $TERMEN=1$, termr enable

Note:

- (1) Excluding possible additional RF interference of 100mV peak sine wave beyond 450MHz.
- (2) This table value includes a ground difference of 50mV between the transmitter and the receiver, the static common-mode level tolerance and variations below 450MHz.

LP Receiver DC Specification

Parameter	Symbol	Rating			Unit	Note
		Min	Typ	Max		
Logic 1 input voltage	V_{IH}	880	-	-	mV	
Logic 0 input voltage, not in ULP State	V_{IL}	-	-	550	mV	
Input hysteresis	V_{HYST}	25	-	-	mV	

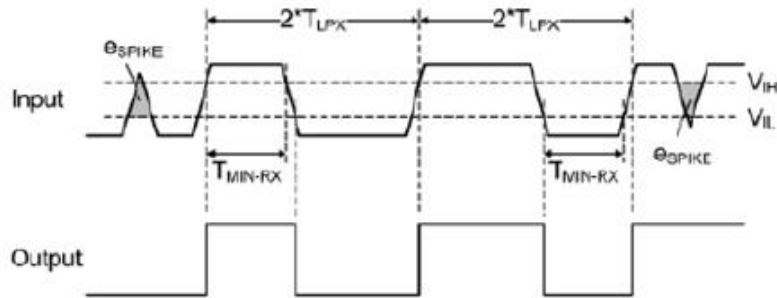

Line Contention Detection

Parameter	Symbol	Rating			Unit	Note
		Min	Typ	Max		
Logic 1 contention threshold	V_{IHCD}	450	-	-	mV	
Logic 0 contention threshold	V_{ILCD}	-	-	200	mV	

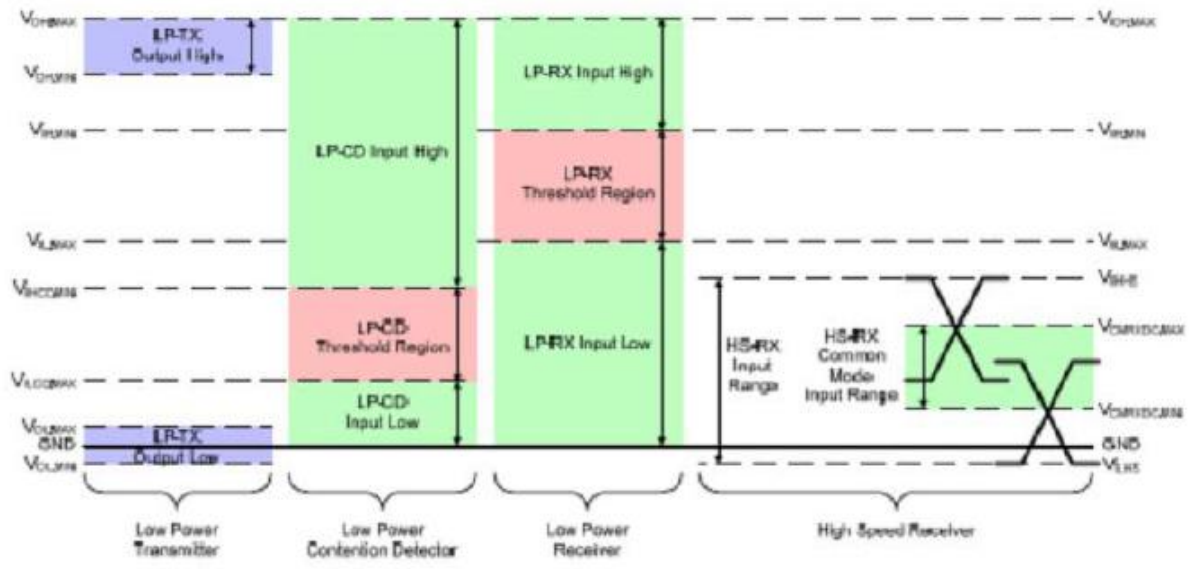

MIPI AC Chrematistics

HS Receiver AC Timing Characteristics

Parameter	Symbol	Rating			Unit	Note
		Min	Typ	Max		
Bandwidth per lane	-	-	-	1000	Mbps	Bandwidth selected by register 'speedup' Speedup=0 → Max=550Mbps Speedup=1 → Max=1000Mbps
Operation frequency	-	-	-	500	MHz	
UI instantaneous	U_{INST}	1	-	12.5	ns	1
Data to Clock Skew	T_{skew}	-0.15	-	0.15	U_{INST}	
Inter-lane static skew	$T_{skew-lane}$	-	-	$U_{INST}/50$	U_{INST}	
Data to Clock Setup Time	T_{SETUP}	0.25	-	-	U_{INST}	2
Data to Clock Hold Time	T_{HOLD}	0.25	-	-	U_{INST}	
Common-mode interference beyond 450MHz	$\Delta V_{CMRX(HF)}$	-	-	100	mV	4
Common-mode interference 50MHz- 450MHz	$\Delta V_{CMRX(LF)}$	-50	-	50	mV	3,6
Common-mode termination	C_{CM}	-	-	60	pF	5

Note:

- (1) Total silicon and package delay budget of $0.3 \cdot U_{INST}$
- (2) Total setup and hold window for receiver of $0.3 \cdot U_{INST}$
- (3) Excluding 'static' ground shift of 50mV
- (4) $\Delta V_{CMRX(HF)}$ is the peak amplitude of a sine wave superimposed on the receiver input
- (5) For higher bit rates a 14pF capacitor will be needed to meet the common-mode return loss specification.
- (6) Voltage difference compared to the DC average common-mode potential.

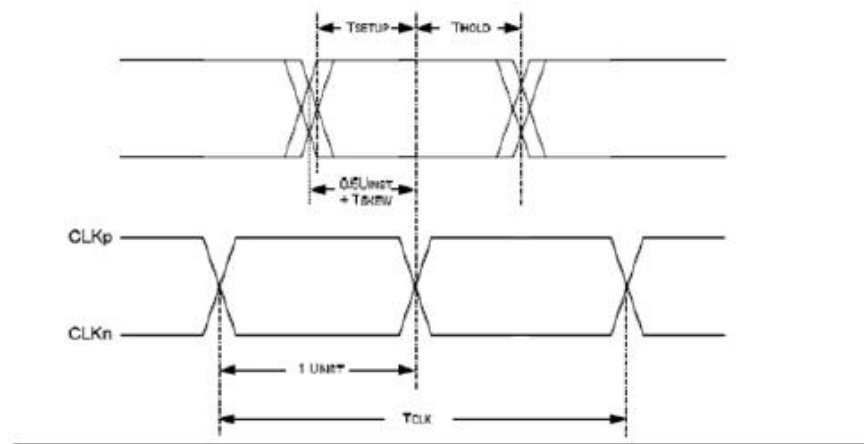

6. Optical Specifications

Item	Symbol	Condition	Min.	Typ.	Max.	Unit	Note
Viewing Angle (CR≥10) B/L ON	θ_T	$\Phi=90^\circ$ (12 o'clock)	75	80	-	deg	Note2
	θ_B	$\Phi=270^\circ$ (6 o'clock)	75	80	-	deg	Note2
	θ_L	$\Phi=180^\circ$ (9 o'clock)	75	80	-	deg	Note2
	θ_R	$\Phi=0^\circ$ (3 o'clock)	75	80	-	deg	Note2
Response Time	T_{ON}	Normal $\theta=\Phi=0^\circ$	-	15	20	msec	Note4
	T_{OFF}		-	15	20	msec	Note4
Contrast Ratio	CR		800	1000	-	-	Note1 Note3
Color Chromaticity	W_X		TBD	TBD	TBD	-	Note1 Note5
	W_Y		TBD	TBD	TBD	-	Note1 Note5
Luminance	L		400	500	-	cd/m ²	Note1 Note7
Luminance Uniformity	Y_U		75	80	-	%	Note1 Note6
NTSC	-		-	50	-	%	-

Note 1: Definition of optical measurement system

The optical characteristics should be measured in dark room. After 5 minutes operation, the optical properties are measured at the center point of the LCD screen. All input terminals LCD panel must be ground when measuring the center area of the panel.

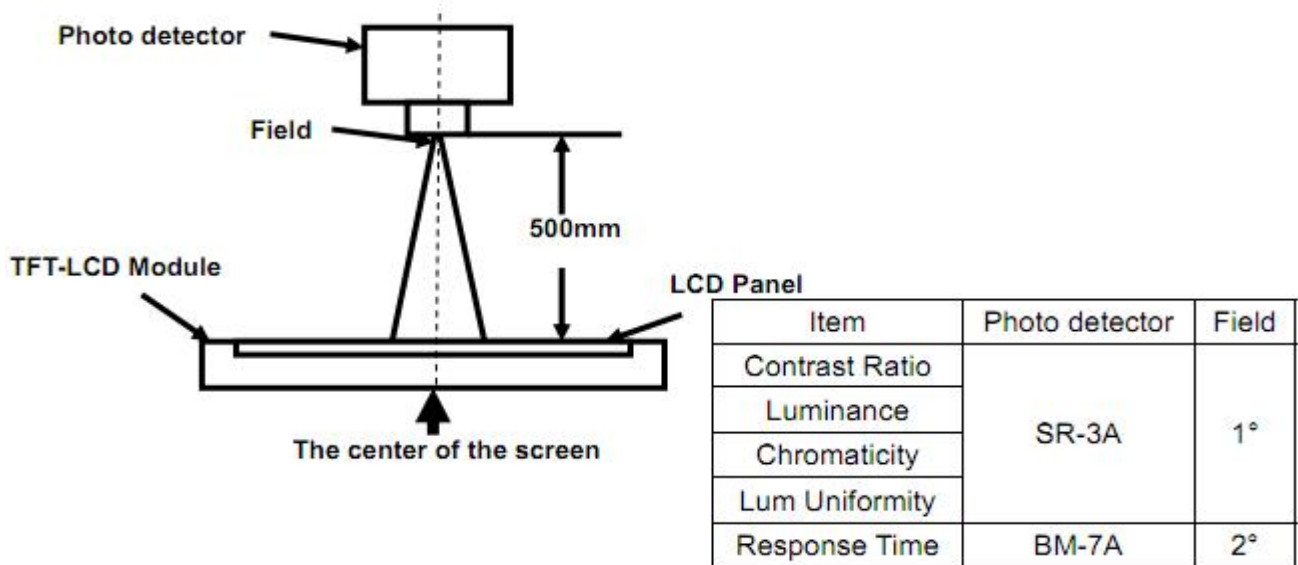

Note 2: Definition of viewing angle range and measurement system

Viewing angle is measured at the center point of the LCD by CONOSCOPE(ergo-80).

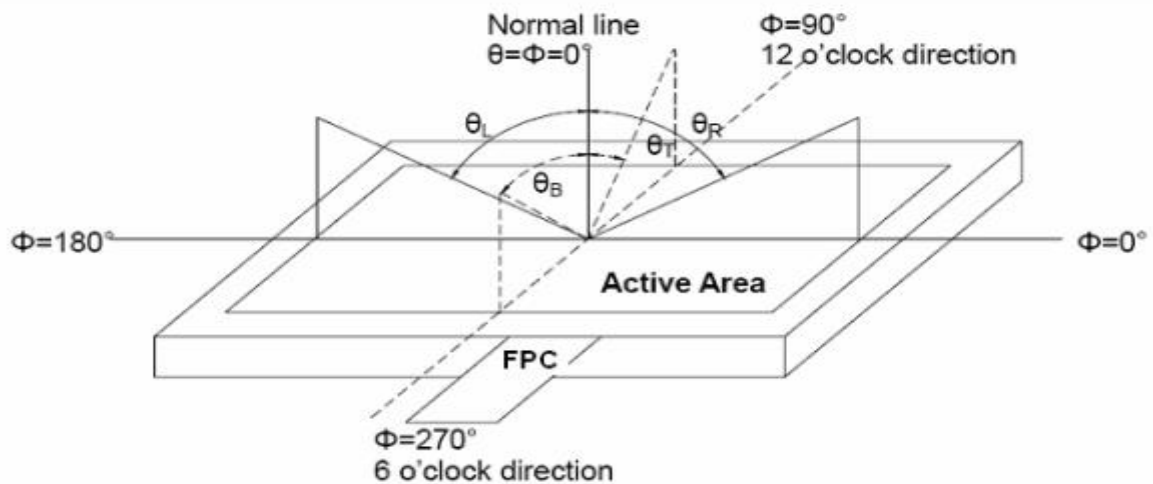

Fig. 1 Definition of viewing angle

Note 3: Definition of contrast ratio

$$CR = \frac{\text{Luminance with all pixels white}}{\text{Luminance with all pixels black}}$$

Note 4: Definition of Response time

The response time is defined as the LCD optical switching time interval between “White” state and “Black”state. Rise time (TON) is the time between photo detector output intensity changed from 90% to 10%. And fall time (TOFF) is the time between photo detector output intensity changed from 10% to 90%.

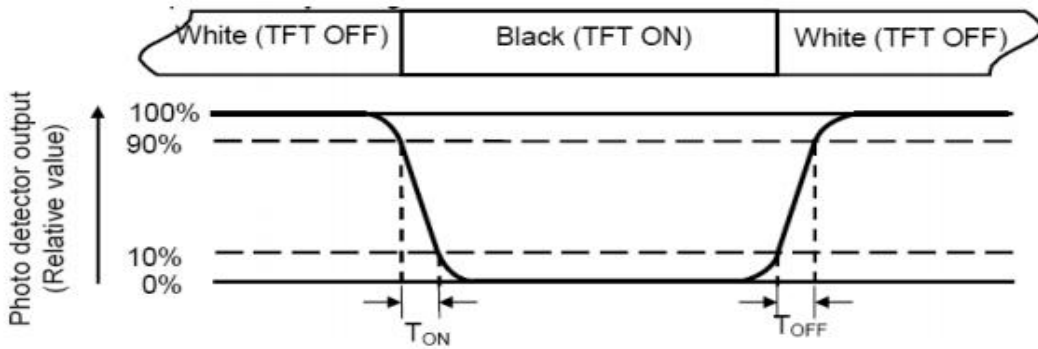

Note 5: Definition of color chromaticity (CIE1931)

Color coordinates measured at center point of LCD.

Note 6: Definition of Luminance Uniformity

The luminance uniformity in surface luminance is determined by measuring luminance at each test position 1 through n, and then dividing the maximum luminance of n points luminance by minimum luminance of n points luminance. For more information see FIG.2.

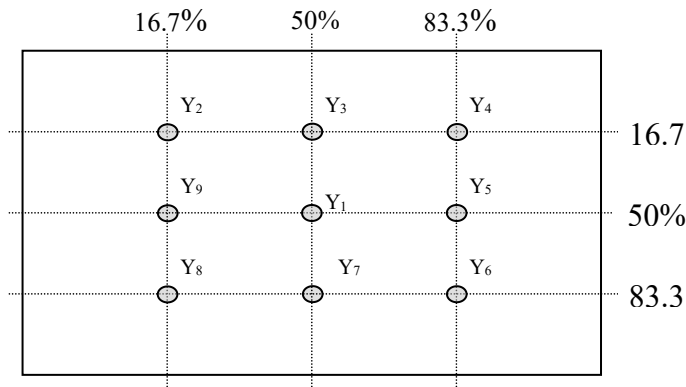

Fig. 2 Definition of points

Note 7: Definition of Luminance (Refer Fig. 2)

Surface luminance is the luminance with all pixels displaying white.

$L_v = \text{Average Surface Luminance with all white pixels}(P_1, P_2, P_3, \dots, P_n)$.

7. Reliability Test Items

Test Item	Test Conditions
High Temperature Storage	Ta= +80°C 96hrs
Low Temperature Storage	Ta= -30°C 96hrs
High Temperature Operation	Ta= +70°C 96hrs
Low Temperature Operation	Ta= -20°C 96hrs
High Temperature and Humidity Storage	Ta= +60°C, 90% RH 96hrs
Thermal Shock (Non-operation)	-30°C/30 min ~ +80°C/30 min for 20 cycles Start with cold temperature end with high temperature
Electro Static Discharge	Contact = ± 4 kV, class B Air = ± 8 kV, class B R=330Ω,C=150pF
Vibration	Sweep: 10Hz~55Hz~10Hz Stroke: 1.5mm 2 hrs for each direction of X .Y. Z.
Mechanical Shock	60G 6ms,±X,±Y,±Z 3 times for each direction
Package Drop Test	Height: 60 cm 1 corner, 3 edges, 6 surfaces

Notes: The test result shall be evaluated after the sample has been left at room temperature and humidity for 2 hours without load. No condensation shall be accepted. The sample will not be accepted if appear these defects:

- 1). Air bubble in the LCD
- 2). Seal leak or Glass crack
- 3). Non display or abnormal display
- 4). Brightness reduction >50%

8. Mechanical Drawing

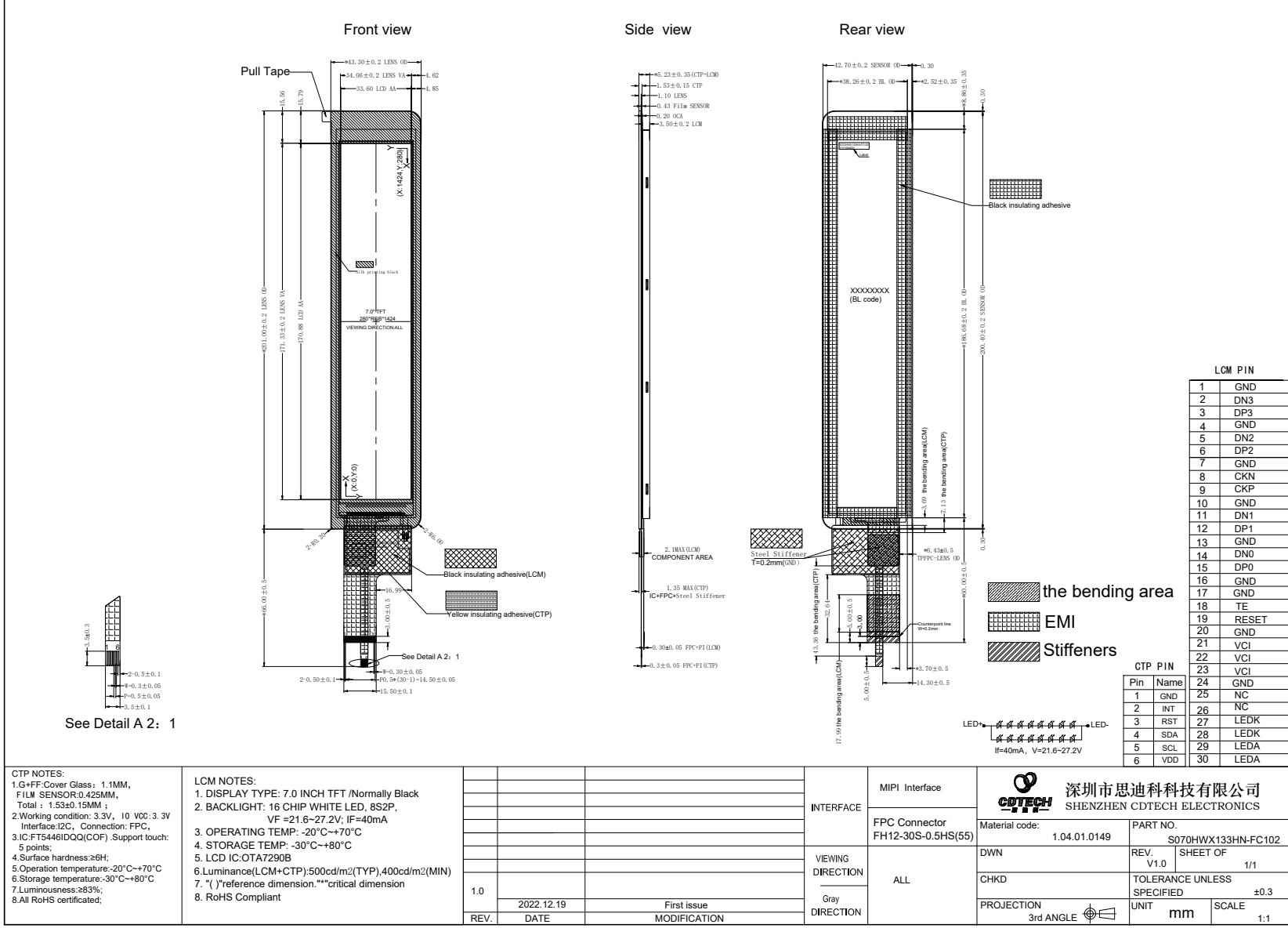

9. Packing

Packing Method

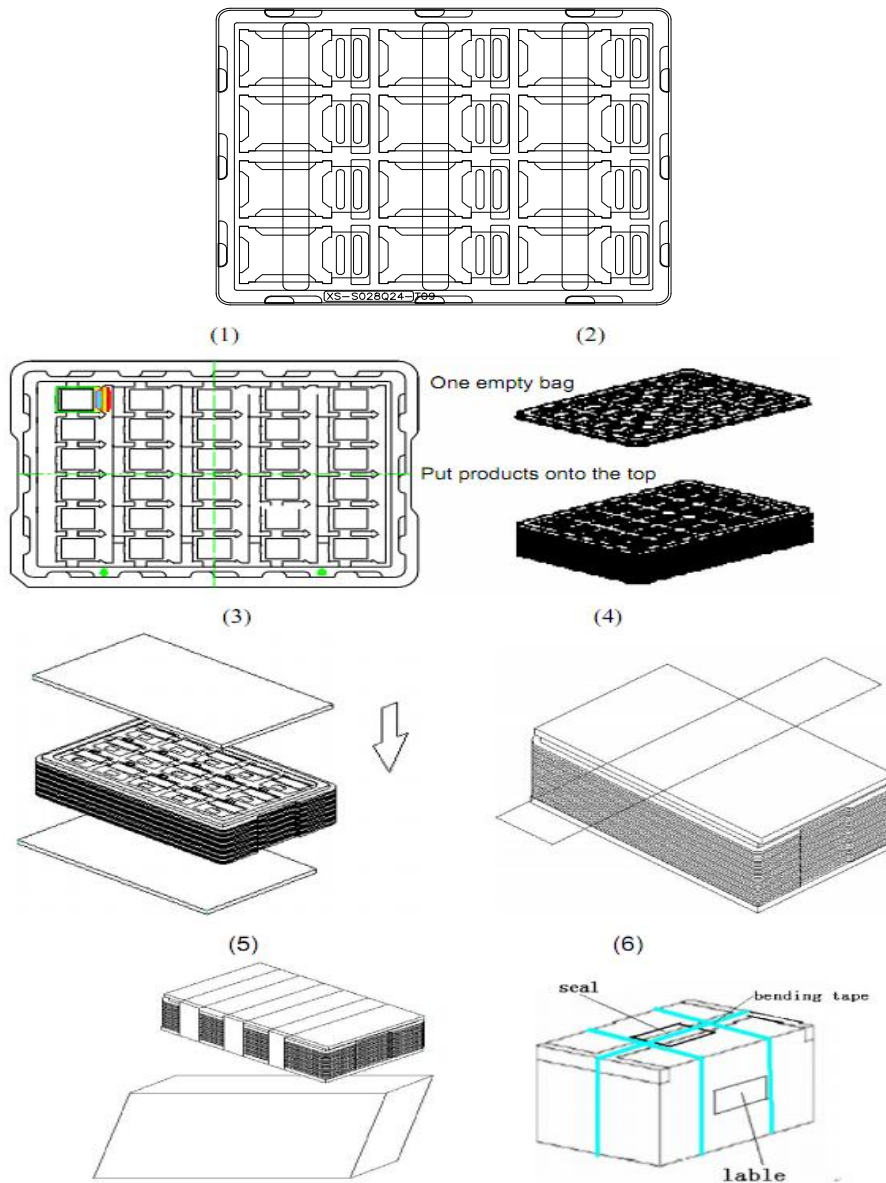

Steps:

1. Put module into tray cavity
2. Tray stacking
3. Put 1 cardboard under the tray stack and 1 cardboard above
4. Fix the cardboard to the tray stack with adhesive tape
5. Put the tray stack into carton
6. Carton sealing with adhesive tape

10. Precautions for Use of LCD modules

10.1 Handling Precautions

10.1.1. The display panel is made of glass. Do not subject it to a mechanical shock by dropping it from a high place, etc.

10.1.2. If the display panel is damaged and the liquid crystal substance inside it leaks out, be sure not to get any in your mouth, if the substance comes into contact with your skin or clothes, promptly wash it off using soap and water.

10.1.3. Do not apply excessive force to the display surface or the adjoining areas since this may cause the color tone to vary.

10.1.4. The polarizer covering the display surface of the LCD module is soft and easily scratched. Handle this polarizer carefully.

10.1.5. If the display surface is contaminated, breathe on the surface and gently wipe it with a soft dry cloth. If still not completely clear, moisten cloth with one of the following solvents:

- Isopropyl alcohol
- Ethyl alcohol

Solvents other than those mentioned above may damage the polarizer. Especially, do not use the following:

- Water
- Ketene
- Aromatic solvents

10.1.6. Do not attempt to disassemble the LCD Module.

10.1.7. If the logic circuit power is off, do not apply the input signals.

10.1.8. To prevent destruction of the elements by static electricity, be careful to maintain an optimum work environment.

10.1.8.1. Be sure to ground the body when handling the LCD Modules.

10.1.8.2. Tools required for assembly, such as soldering irons, must be properly ground.

10.1.8.3. To reduce the amount of static electricity generated, do not conduct assembly and other work under dry conditions.

10.1.8.4. The LCD Module is coated with a film to protect the display surface. Be care when peeling off this protective film since static electricity may be generated.

10.2 Storage Precautions

10.2.1. When storing the LCD modules, avoid exposure to direct sunlight or to the light of fluorescent lamps.

10.2.2. The LCD modules should be stored under the storage temperature range if the LCD modules will be stored for a long time, the recommend condition is :

Temperature : 0°C ~40°C Relatively humidity: ≤80%

10.2.3. The LCD modules should be stored in the room without acid, alkali and harmful gas.

10.3 Transportation Precautions

The LCD modules should be no falling and violent shocking during transportation, and also should avoid excessive press, water, damp and sunshine.