

PRODUCT SPECIFICATION

CDTECH Model: **S070BWS151ET**

CUSTOMER Model: **-**

Description: **7.0 " TFT-LCD Module**

Version: **1.0**

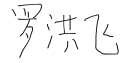
CDTECH	PREPARED BY	CHECKED BY	APPROVED BY
SIGNATURE			
DATE	2024.1.23	2024.1.23	2024.1.23

CUSTOMER APPROVAL	SIGNATURE	DATE



Contents

1. General Specifications	4
2. Absolute Maximum Ratings	4
3. Electrical Characteristics	5
4. Interface Pin Assignment	6
5. Interface Characteristics	8
6. Optical Specifications	11
7. Reliability Test Items	15
8. Mechanical Drawing	16
9. Packing	17
10. Precautions for Use of LCD modules	18

1. General Specifications

1.1 LCM General Information

Item	Specification	Unit
LCD Size	7.0	inch
Number of Pixels	1024 (H) RGB x 600 (V)	pixels
Display Mode	Normally Black	-
Viewing Direction	Free	o' clock
Interface	LVDS	-
Display Colors	16.7M	colors
Outline Dimension	164.3 (H) x 97.3 (V) x 2.8 (D)	mm
Active Area	154.21 (H) x 85.92 (V)	mm
Pixel Pitch	0.1505 (H) x 0.1432 (V)	mm
Driver IC	EK79001+EK73215	-
Operation Temperature	-20~70	°C
Storage Temperature	-30~80	°C

Note1:Requirements on environmental protection RoHS compliant.

2. Absolute Maximum Ratings

Item	Symbol	MIN.	MAX.	Unit	Note
Analog Supply voltage	VDD	-0.3	5.0	V	Note 1

Note 1:Permanent damage may occur to the LCD module if beyond this specification.

Functional operation should be restricted to the conditions described under normal operating conditions.

3. Electrical Characteristics

3.1 Recommended Operating Condition for TFT LCD

Item	Symbol	Min.	Typ.	Max.	Unit	Note
Analog Supply voltage	VDD	3.0	3.3	3.6	V	
Analog supply current	I _{VDD}	-	TBD	-	mA	VDD=3.3V
Power supply for LCD	AVDD	9.0	9.6	10.5	V	
	VGH	16.0	18.0	20	V	
	VGL	-7.5	-6.0	-5.0	V	
	VCOM	2.9	3.2	3.5	V	
Logic input voltage	VIH	0.7*VDD	-	VDD	V	
	VIL	GND	-	0.3*VDD	V	

3.2 Recommended Driving Condition for Backlight

Item	Symbol	Min.	Typ.	Max.	Unit	Note
Driving Current	I _F	-	200	-	mA	
Driving Voltage	V _F	8.1	-	10.2	V	
Power consumption	W _{BL}	1.62	-	2.04	W	
LED Life-Time	N/A	-	50,000	-	Hours	Ta=25°C Note 1

Note 1:LED lifetime is defined as the module brightness decay 50% of original brightness at Ta=25 degree, typical current.

Note 2:LED circuit :

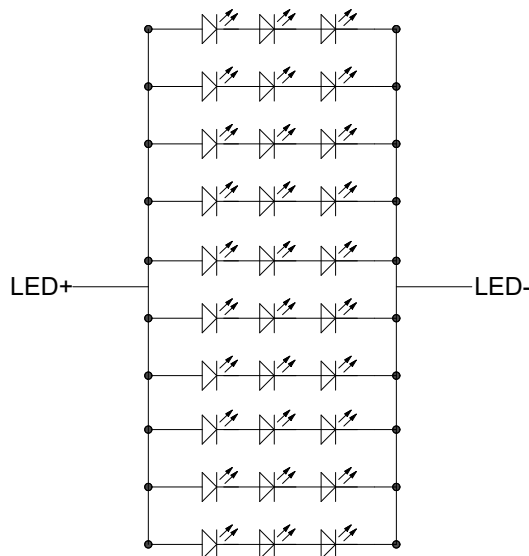

4. Interface Pin Assignment

4.1 LCM Pin Assignment

No.	Symbol	Description
1	VCOM	Common Voltage
2-3	VDD	Power supply
4	NC	No connection
5	RESET	Global reset pin
6	STBYB	Standby mode Normally pulled high STBYB=1,normal operation STBYB=0timing contrller,source driver will turn off,all output are High-Z
7	GND	Ground
8	RXIN0-	- LVDS differential data input
9	RXIN0+	+ LVDS differential data input
10	GND	Ground
11	RXIN1-	- LVDS differential data input
12	RXIN1+	+ LVDS differential data input
13	GND	Ground
14	RXIN2-	- LVDS differential data input
15	RXIN2+	+ LVDS differential data input
16	GND	Ground
17	RXCLK-	-LVDS differential clock input
18	RXCLK+	+LVDS differential clock input
19	GND	Ground
20	RXIN3-	- LVDS differential data input
21	RXIN3+	+ LVDS differential data input
22	GND	Ground
23	NC	No connection
24	NC	No connection
25	GND	Ground
26	NC	No connection
27	DIMO	Backlight CABC controller signal output
28	SELB(HSD)	6bit/8bit mode select (Note 1)
29	AVDD	Power for Analog Circuit
30	GND	Ground
31	LED-	Power for LED backlight (Cathode)
32	LED-	Power for LED backlight (Cathode)
33	L/R	Horizontal inversion (Note 2)
34	U/R	Vertical inversion (Note 2)
35	VGL	Gate off Voltage



36	NC	No connection
37	NC	No connection
38	VGH	Gate on Voltage
39	LED+	Power for LED backlight (Anode)
40	LED+	Power for LED backlight (Anode)

Note 1: if LVDS input data is 6bit,selb must be set to high
if LVDS input data is 8bit,selb must be set to low

Note 2: when L/R=0 set right to left scan direction
when L/R=1 set left to right scan direction
when U/D=0 set top to bottom scan direction
when U/D=1 set bottom to top scan direction

5. Interface Characteristics

5.1 Power Sequence

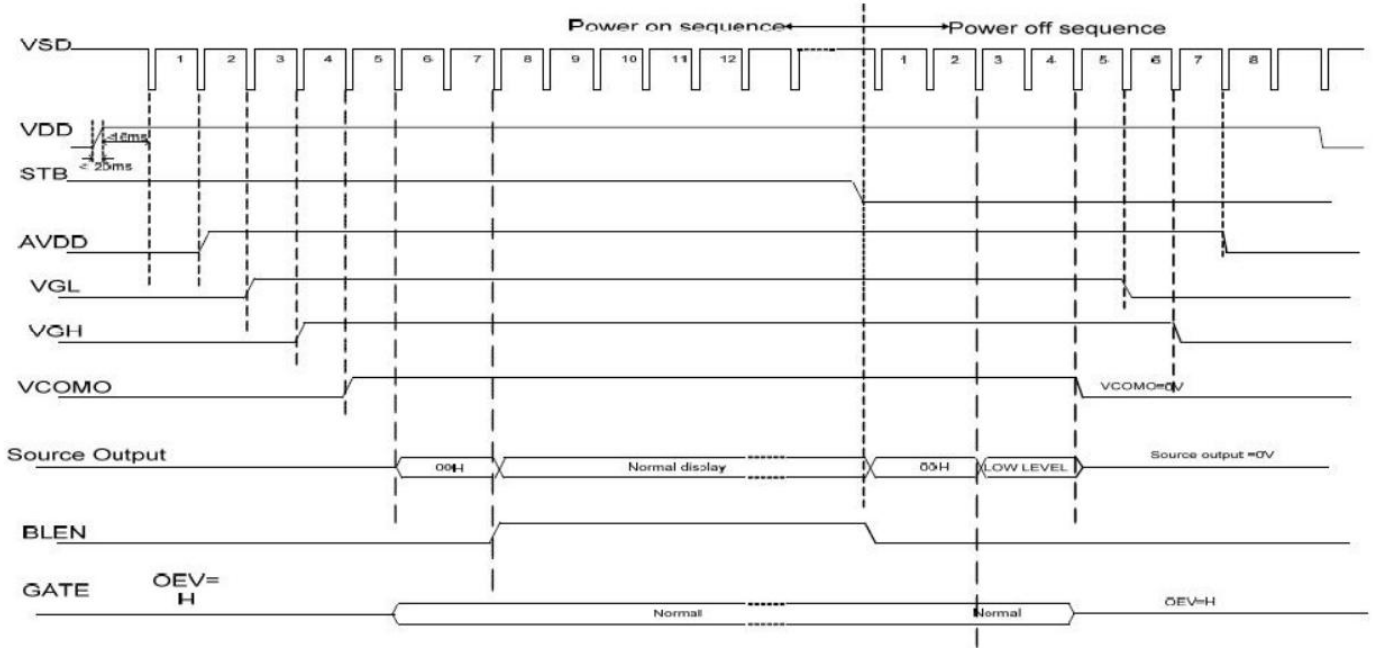

Power On/Off timing chart

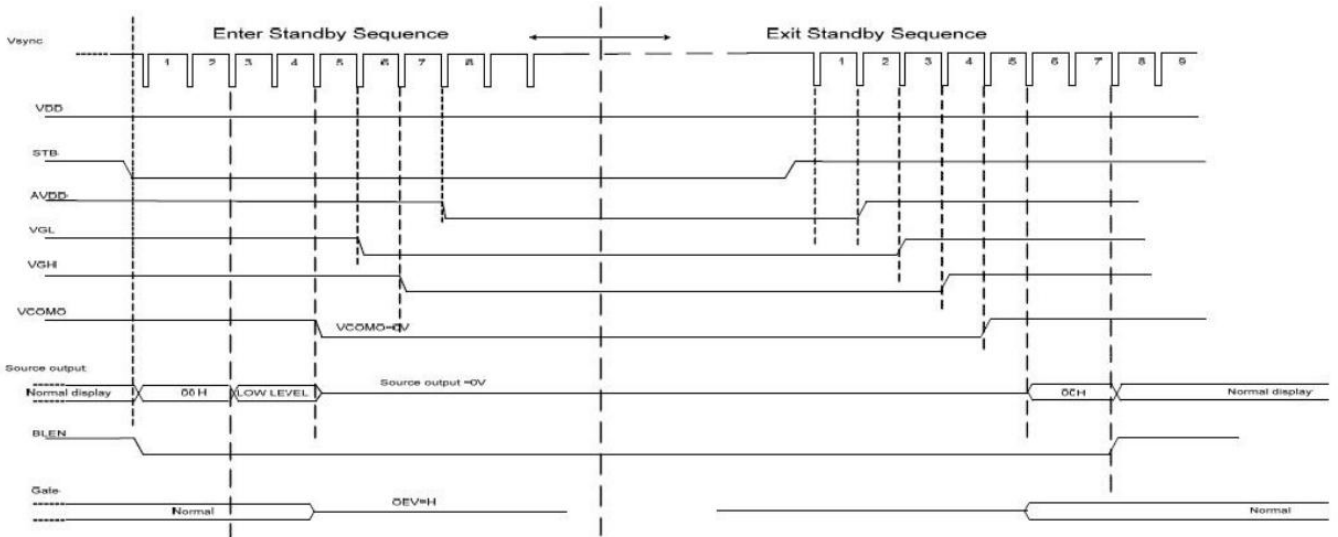

Enter and Exit Standby Mode timing chart

5.2 Timing Characteristics

LVDS DC characteristic

Parameter	Symbol	Min.	Typ.	Max.	Unit	Condition
Differential input high threshold voltage	RxVTH			+0.1V	V	RxVCM=1.2V
Differential input low threshold voltage	RxVTL	-0.1			V	
Input voltage range(single-end)	RxVIN	0		2.4	V	
Differential input common mode voltage	RxVCM	$ V_{ID} /2$		$2.4 - V_{ID} /2$	V	
Differential input voltage	$ V_{ID} $	0.2		0.6	V	
Differential input leakage current	RxVTH	-10		+10	V	
LVDS Digital Operating Current	Iddlvsd	-	40(TBD)	50	mA	Fclk=65Mhz, VDD=3.3V
LVDS Digital Standby Current	Istlvds	-	10(TBD)	50	uA	Clock & all functions are stop

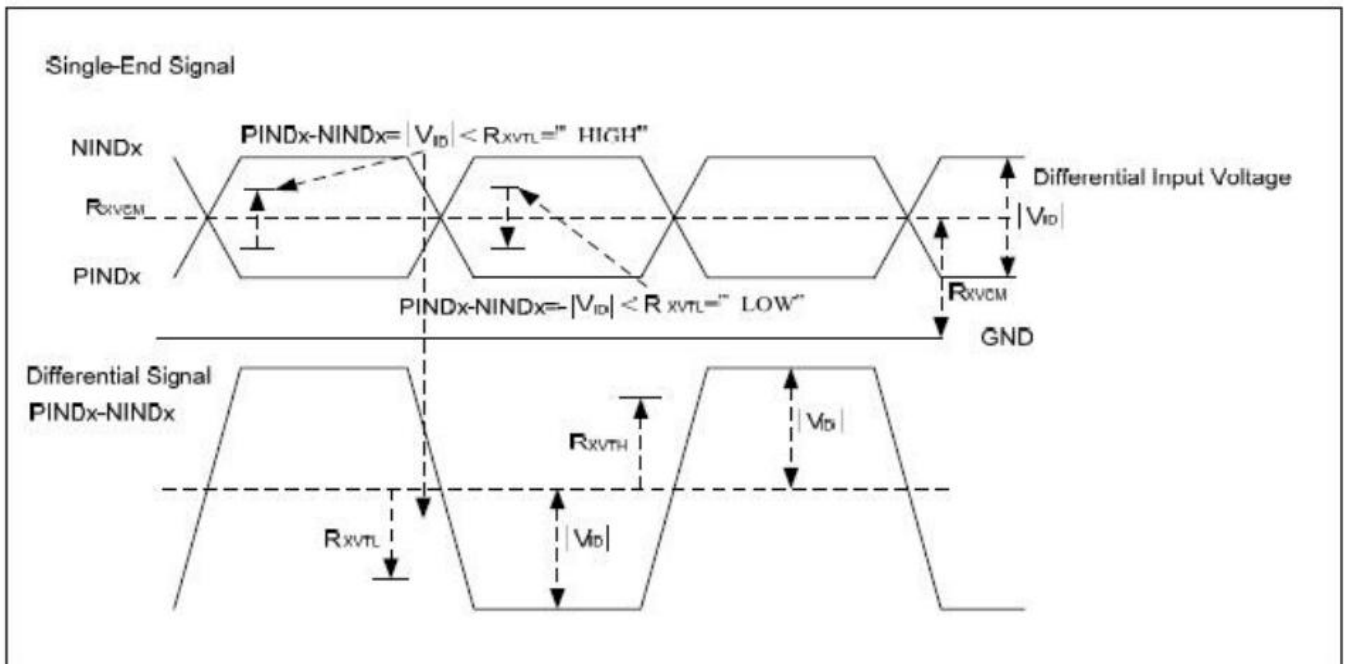

LVDS mode

Parameter	Symbol	Condition	Min.	Typ.	Max.	Unit
Clock Frequency	RxFCLK		20	-	71	MHz
Input data skew margin	TRSKM	$ VID =400mV$ $RxVCM=1.2V$ $RxFCLK=71MHz$	500			ps
Clock High Time	TLVCH			$4/(7 * RxFCLK)$		ns
						ns
Clock Low Time	TLVCL			$3/(7 * RxFCLK)$		ns
PLL wake-up-time	TenPLL				150	us

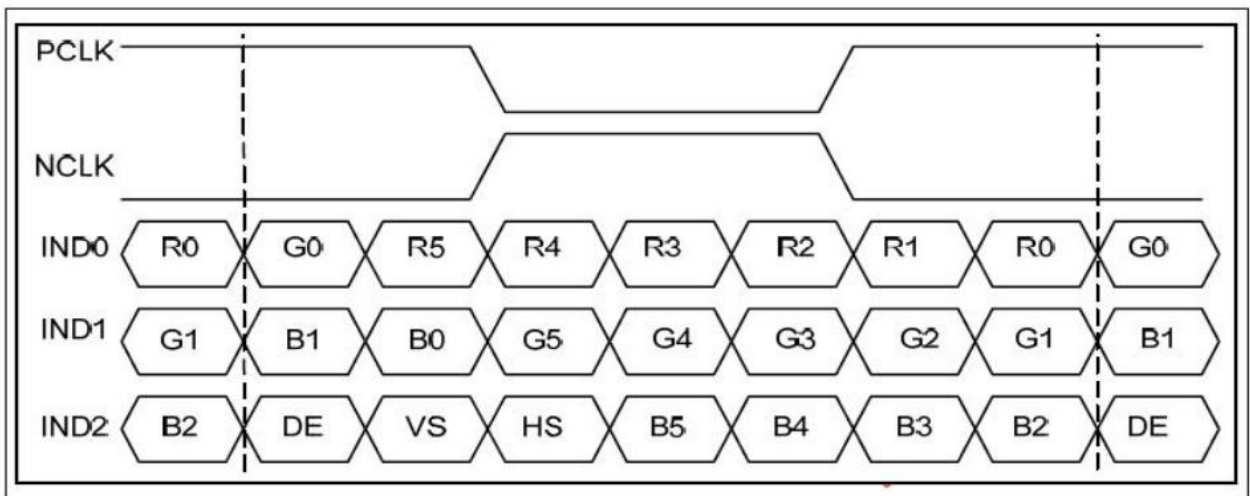

6-bit LVDS Input timing chart

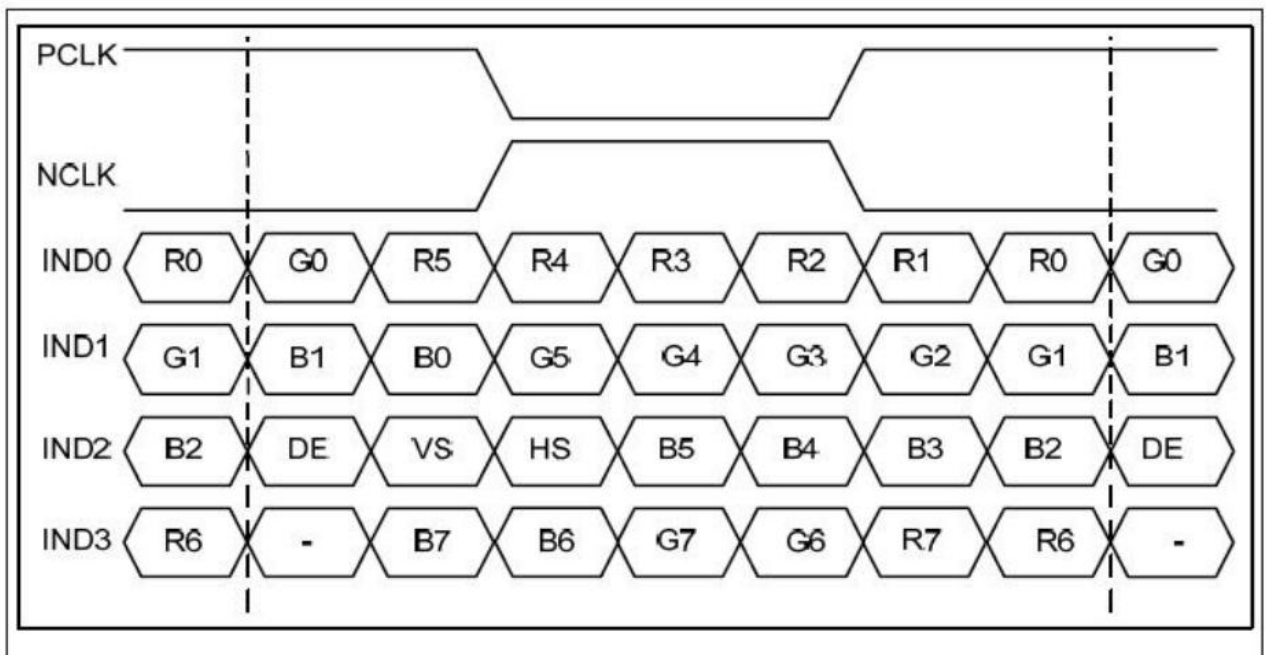

8-bit LVDS Input timing chart

6. Optical Specifications

Item	Symbol	Condition	Min.	Typ.	Max.	Unit	Note
Viewing Angle (CR≥10) B/L ON	θ_T	$\Phi=90^\circ$ (12 o'clock)	-	85	-	deg	Note2
	θ_B	$\Phi=270^\circ$ (6 o'clock)	-	85	-	deg	Note2
	θ_L	$\Phi=180^\circ$ (9 o'clock)	-	85	-	deg	Note2
	θ_R	$\Phi=0^\circ$ (3 o'clock)	-	85	-	deg	Note2
Response Time	T_{ON}	Normal $\theta=\Phi=0^\circ$	-	15	20	msec	Note4
	T_{OFF}		-	15	20	msec	Note4
Contrast Ratio	CR		-	800	-	-	Note1 Note3
Color Chromaticity	W_X		TBD	TBD	TBD	-	Note1 Note5
	W_Y		TBD	TBD	TBD	-	Note1 Note5
Luminance	L		700	800	-	cd/m ²	Note1 Note7
Luminance Uniformity	Y_U		75	80	-	%	Note1 Note6
NTSC	-		-	50	-	%	-

Note 1: Definition of optical measurement system

The optical characteristics should be measured in dark room. After 5 minutes operation, the optical properties are measured at the center point of the LCD screen. All input terminals LCD panel must be ground when measuring the center area of the panel.

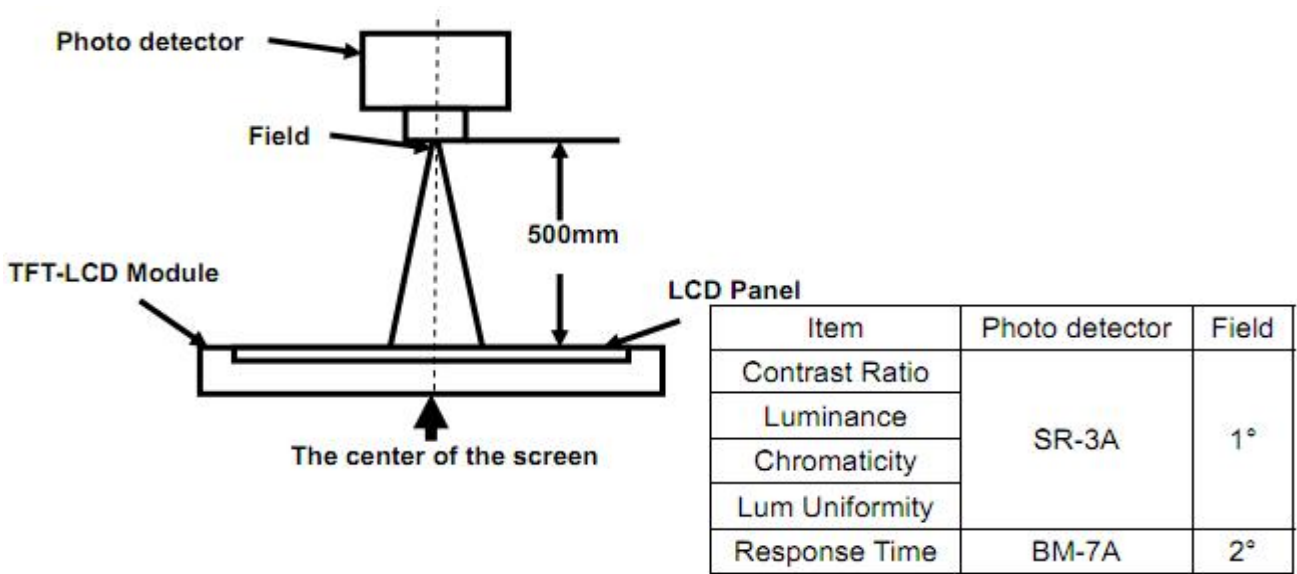

Fig 1

Note 2: Definition of viewing angle range and measurement system.

viewing angle is measured at the center point of the LCD by CONOSCOPE(ergo-80).

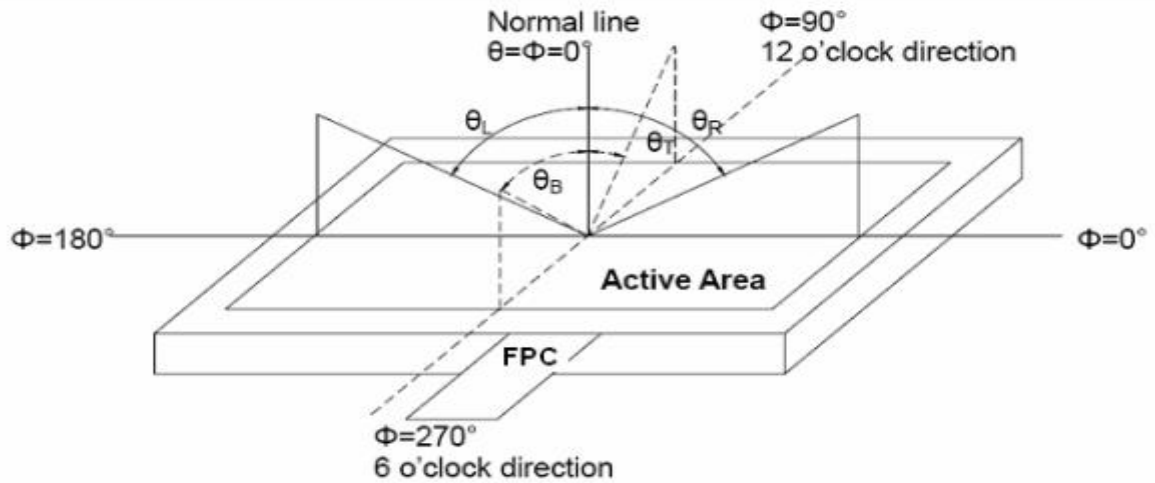

Fig 2 Definition of viewing angle

Note 3: Definition of contrast ratio

$$CR = \frac{\text{Luminance with all pixels white}}{\text{Luminance with all pixels black}}$$

Note 4: Definition of Response time

The response time is defined as the LCD optical switching time interval between “White” state and “Black” state. Rise time (TON) is the time between photo detector output intensity changed from 90% to 10%. And fall time (TOFF) is the time between photo detector output intensity changed from 10% to 90%.

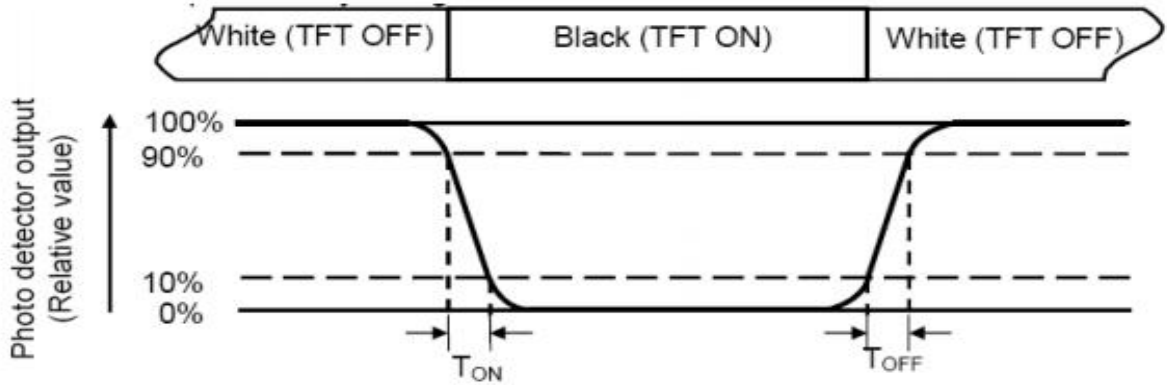

Note 5: Definition of color chromaticity (CIE1931)

Color coordinates measured at center point of LCD.

Note 6: Definition of Luminance Uniformity

The luminance uniformity in surface luminance is determined by measuring luminance at each test position 1 through n, and then dividing the maximum luminance of n points luminance by minimum luminance of n points luminance. For more information see FIG.3-a/b

Note 7: Surface luminance is the luminance with all pixels displaying white.

L_v = Average Surface Luminance with all white pixels (P1, P2, P3, ..., Pn)

For more information see FIG.3-a/b

Note 8: Size : $S \leq 5"$ (see Figure a) A : 5 mm B : 5 mm. H, V : Active area

Light spot size $\varnothing = 5\text{mm}$ (BM-5) or $\varnothing = 7.7\text{mm}$ (BM-7) 50cm distance or test spot position : see Figure a.

measurement instrument : TOPCON's luminance meter SR-3A or BM-7 or compatible (see Figure 1).

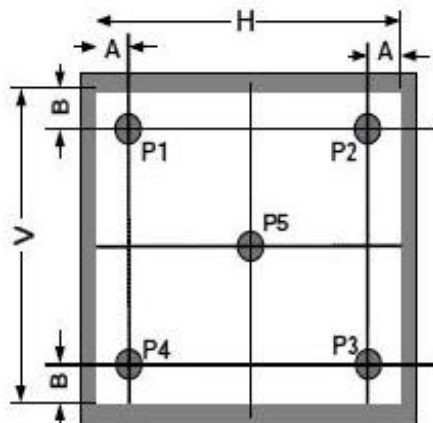

Fig. 3-a Definition of points

$5'' < S \leq 12.3''$ (see Figure b) . H,V : Active area

Light spot size $\varnothing = 5\text{mm}$ (BM-5) or $\varnothing = 7.7\text{mm}$ (BM-7) 50cm distance or compatible distance from the LCD surface to detector lens. test spot position : see Figure b.

measurement instrument : TOPCON's luminance meter SR-3A or BM-7 or compatible (see Figure 1).

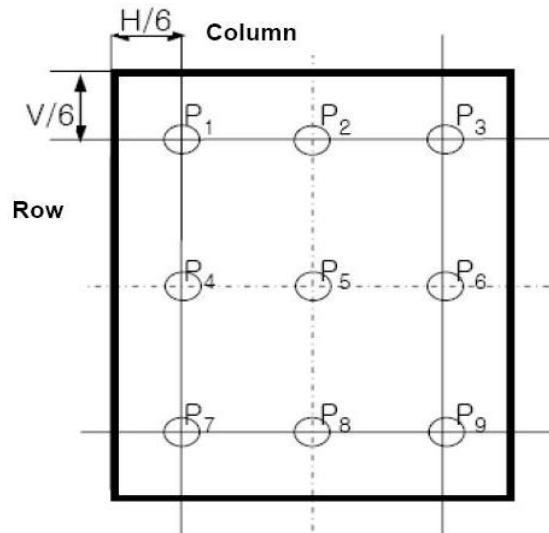

Fig. 3-b Definition of points

7. Reliability Test Items

Test Item	Test Conditions
High Temperature Storage	Ta= +80°C 96hrs
Low Temperature Storage	Ta= -30°C 96hrs
High Temperature Operation	Ta= +70°C 96hrs
Low Temperature Operation	Ta= -20°C 96hrs
High Temperature and Humidity Storage	Ta= +60°C, 90% RH 96hrs
Thermal Shock (Non-operation)	-30°C/30 min ~ +80°C/30 min for 20 cycles Start with cold temperature end with high temperature
Electro Static Discharge	Contact = ± 4 kV, class B Air = ± 8 kV, class B R=330Ω,C=150pF
Vibration	Sweep: 10Hz~55Hz~10Hz Stroke: 1.5mm 2 hrs for each direction of X .Y. Z.
Mechanical Shock	60G 6ms,±X,±Y,±Z 3 times for each direction
Package Drop Test	Height: 60 cm 1 corner, 3 edges, 6 surfaces

Notes: The test result shall be evaluated after the sample has been left at room temperature and humidity for 2 hours without load. No condensation shall be accepted. The sample will not be accepted if appear these defects:

- 1). Air bubble in the LCD
- 2). Seal leak or Glass crack
- 3). Non display or abnormal display
- 4). Brightness reduction >50%

8. Mechanical Drawing

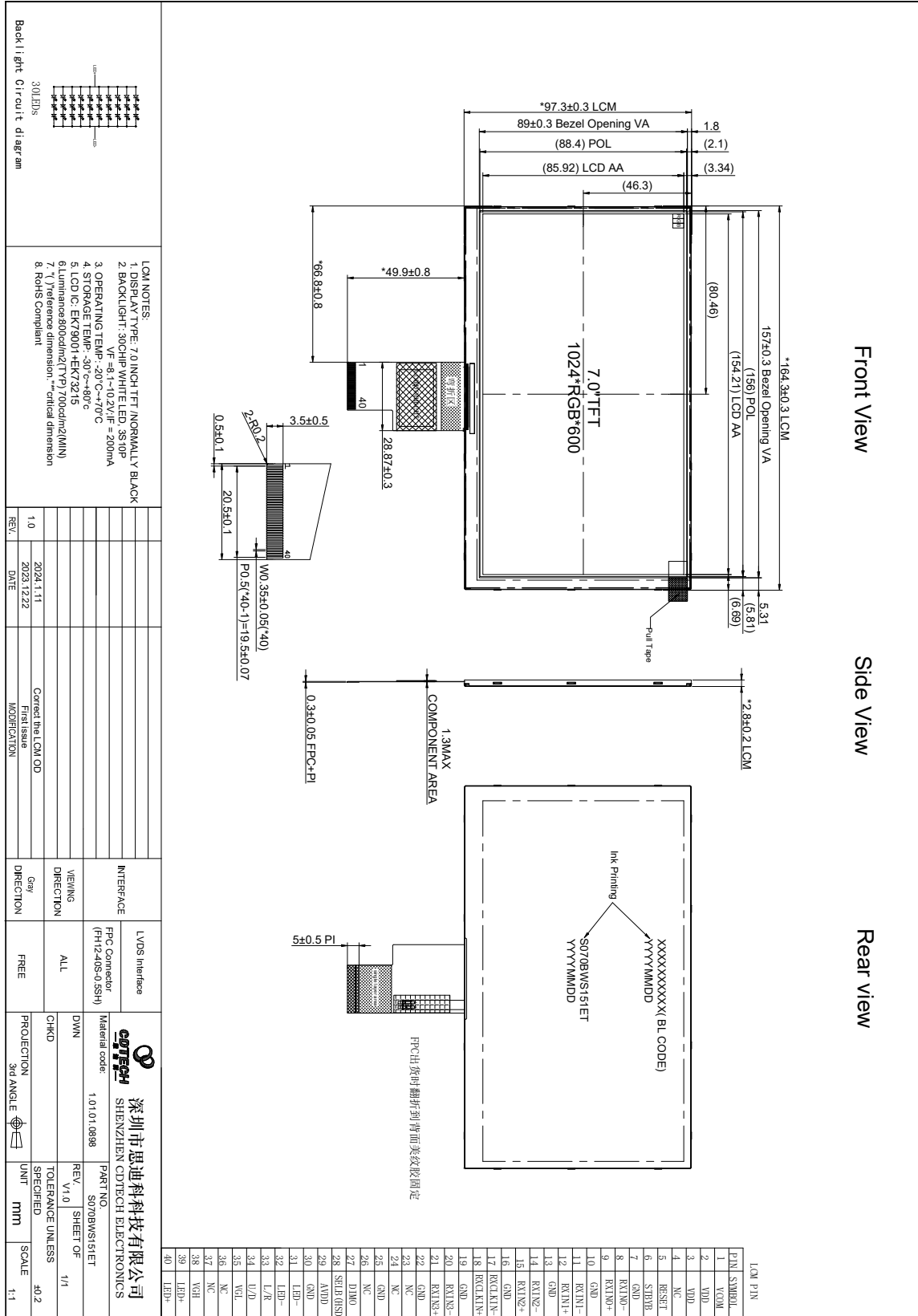

9. Packing

Packing Method

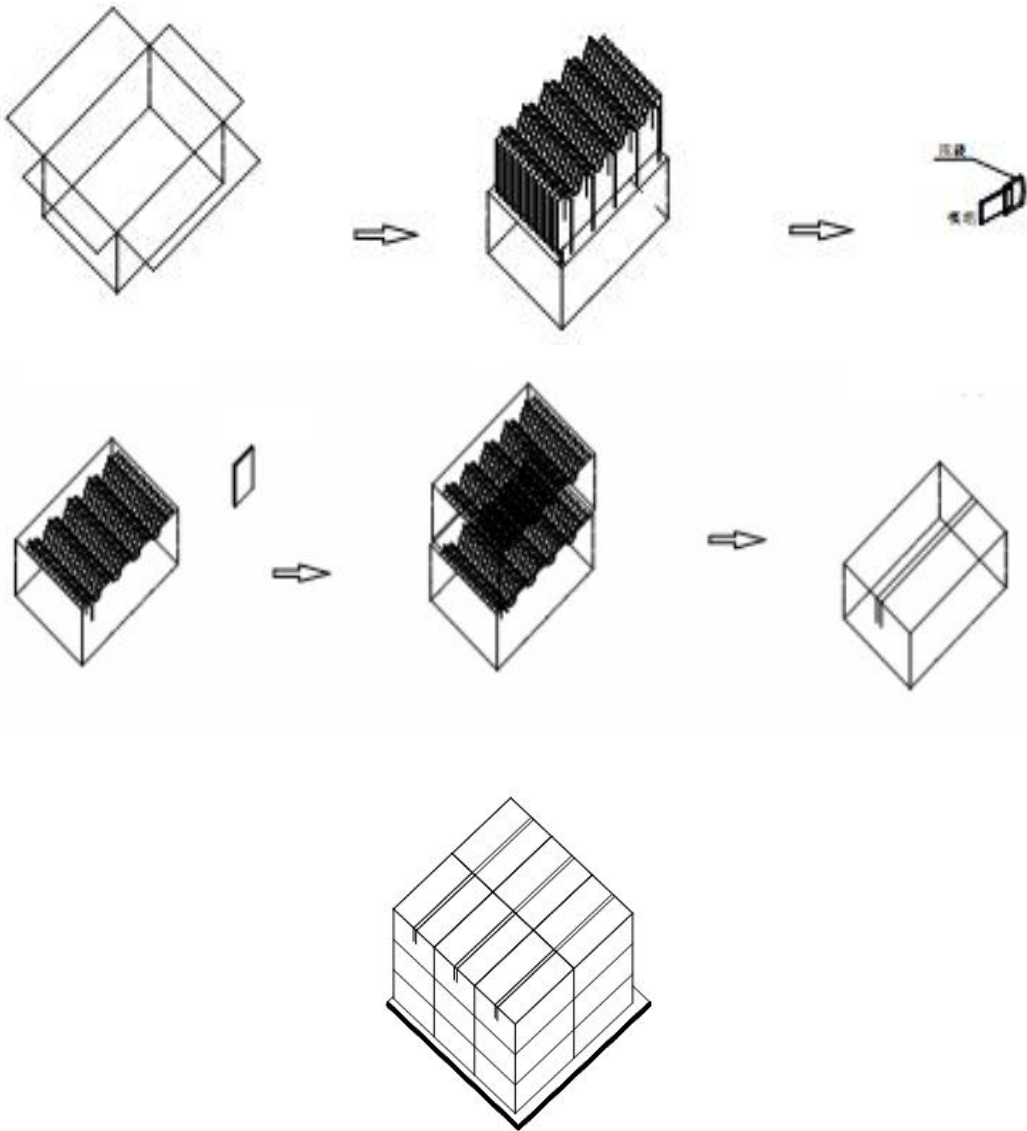

10. Precautions for Use of LCD modules

10.1 Handling Precautions

10.1.1. The display panel is made of glass. Do not subject it to a mechanical shock by dropping it from a high place, etc.

10.1.2. If the display panel is damaged and the liquid crystal substance inside it leaks out, be sure not to get any in your mouth, if the substance comes into contact with your skin or clothes, promptly wash it off using soap and water.

10.1.3. Do not apply excessive force to the display surface or the adjoining areas since this may cause the color tone to vary.

10.1.4. The polarizer covering the display surface of the LCD module is soft and easily scratched. Handle this polarizer carefully.

10.1.5. If the display surface is contaminated, breathe on the surface and gently wipe it with a soft dry cloth. If still not completely clear, moisten cloth with one of the following solvents:

- Isopropyl alcohol
- Ethyl alcohol

Solvents other than those mentioned above may damage the polarizer. Especially, do not use the following:

- Water
- Ketene
- Aromatic solvents

10.1.6. Do not attempt to disassemble the LCD Module.

10.1.7. If the logic circuit power is off, do not apply the input signals.

10.1.8. To prevent destruction of the elements by static electricity, be careful to maintain an optimum work environment.

10.1.8.1. Be sure to ground the body when handling the LCD Modules.

10.1.8.2. Tools required for assembly, such as soldering irons, must be properly ground.

10.1.8.3. To reduce the amount of static electricity generated, do not conduct assembly and other work under dry conditions.

10.1.8.4. The LCD Module is coated with a film to protect the display surface. Be care when peeling off this protective film since static electricity may be generated.

10.2 Storage Precautions

10.2.1. When storing the LCD modules, avoid exposure to direct sunlight or to the light of fluorescent lamps.

10.2.2. The LCD modules should be stored under the storage temperature range if the LCD modules will be stored for a long time, the recommend condition is :

Temperature : 0°C ~40°C Relatively humidity: ≤80%

10.2.3. The LCD modules should be stored in the room without acid, alkali and harmful gas.

10.3 Transportation Precautions

The LCD modules should be no falling and violent shocking during transportation, and also should avoid excessive press, water, damp and sunshine.