



PRODUCT SPECIFICATION

CDTECH Model: **S070BWS59HD-DC35**

CUSTOMER Model: **-**

Description: **7.0 " TFT-LCD Module with
CTP/HDMI**

Version: **1.0**

CDTECH	PREPARED BY	CHECKED BY	APPROVED BY
SIGNATURE			
DATE	2023.6.10	2023.6.10	2023.6.10

CUSTOMER APPROVAL	SIGNATURE	DATE



Contents

1. General Specifications	4
2. Absolute Maximum Ratings	5
3. Electrical Characteristics	5
4. Interface Pin Assignment	7
5. Optical Specifications	8
6. Reliability Test Items	11
8. Mechanical Drawing	12
9. Packing	13
10. Precautions for Use of LCD modules	14

1. General Specifications

1.1 LCM General Information

Item	Specification	Unit
LCD Size	7.0	inch
Number of Pixels	1024 (H) RGB x 600 (V)	pixels
Display Mode	Normally Black	-
Viewing Direction	Free	o' clock
Interface	HDMI	-
Display Colors	16.7M	colors
Outline Dimension	165.00 (H) x 100.00 (V) x 7.47 (D)	mm
Active Area	154.21 (H) x 85.92 (V)	mm
Pixel Pitch	0.1505 (H) x 0.1432 (V)	mm
Driver IC	EK79001+EK73215	-
Operation Temperature	-20~70	°C
Storage Temperature	-30~80	°C

1.2 Touch Panel Information

Item	Specification
Touch Structure	G+G
Bonding Type with LCM	Perimeter Bonding
Driver IC	ILI2511
Interface	USB
Touch Count Max	5 Points
Surface treatment	-
Surface hardness	6H
I2C slave address	-
Origin of coordinate	Top Left Corner

Note1: Requirements on environmental protection RoHS compliant.

2. Absolute Maximum Ratings

Item	Symbol	MIN.	MAX.	Unit	Note
Analog Supply voltage	+24V	10	24	V	Note 1

Note 1: Permanent damage may occur to the LCD module if beyond this specification.

Functional operation should be restricted to the conditions described under normal operating conditions.

3. Electrical Characteristics

3.1 Recommended Operating Condition for TFT LCD

Item	Symbol	Min.	Typ.	Max.	Unit	Note
Analog Supply voltage	VDD+24V	10	12	24	V	
Analog supply current	I _{VDD}	-	TBD	-	mA	
Operating Voltage	BL control	-	5	-	V	
Logic input voltage	V _{IH}	0.7*VDD	-	VDD	V	
	V _{IL}	GND	-	0.3*VDD	V	

3.2 Recommended-Driving Condition for Backlight

Item	Symbol	Min.	Typ.	Max.	Unit	Note
Driving Current.	I _F	-	200	-	mA	
Driving Voltage	V _F	8.1	-	10.2	V	
Power consumption	W _{BL}	1.62	-	2.04	W	
LED Life-Time	N/A	--	50,000	-	Hours	Ta=25° C Note 1

Note 1:LED lifetime is defined as the module brightness decay 50% of original brightness at Ta=25 degree typical current.

Note 2:LED circuit:

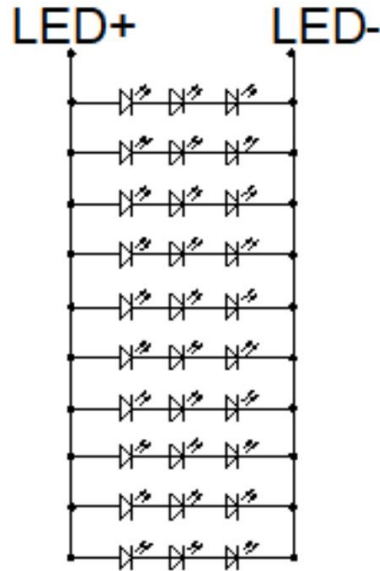

3.3 Touch Panel

Item	Symbol	Min.	Typ.	Max.	Unit	Note
Power Supply voltage	VDD	-	5	-	V	
Analog supply current	I_{VDD}	-	TBD	-	mA	VDD=5V
Input high-level voltage	V_{IH}	$0.7 \cdot VDD$	-	VDD	V	
Input low -level voltage	V_{IL}	GND	-	$0.3 \cdot VDD$	V	

4. Interface Pin Assignment

4.1 LCM Pin Assignment

No.	Symbol	Description
1	TMDS Data 2+	TMDS Transition differential signal 2+
2	TMDS Data2 Sh	Data2 Shielding ground
3	TMDS Data 2-	TMDS Transition differential signal 2-
4	TMDS Data 1+	TMDS Transition differential signal 1+
5	TMDS Data1 Sh	Data1 Shielding ground
6	TMDS Data 1-	TMDS Transition differential signal 1-
7	TMDS Data 0+	TMDS Transition differential signal 0+
8	TMDS Data 0 S	Data0 Shielding ground
9	TMDS Data 0-	TMDS Transition differential signal 0-
10	TMDS Clock+	TMDS Transition differential signal Clock+
11	TMDS Clock Sh	Clock Shielding ground
12	TMDS Clock-	TMDS Transition differential signal Clock-
13	CEC	Electronic protocol CEC
14	NC	No connection
15	SCL	I2C Clock Line
16	SDA	I2C DATA Line
17	DDC/CEC GND	Data display channel
18	+5V	+5V Power
19	Hot Plug Detec	Hot Plug Detec

4.2 Touch FPC Pin Assignment

No.	Symbol	Description
1	GND	Ground
2	DP+	Data+
3	DN-	Data-
4	VDD	Power supply

4.3 Screw Terminal Connector Pin Assignment

No.	Symbol	Description
1	+24V	Power supply
2	GND	GND
3	GND	GND
4	BL conrol	Backlight switch control pin

5. Optical Specifications

Item	Symbol	Condition	Min.	Typ.	Max.	Unit	Note
Viewing Angle (CR≥10) B/L ON	θ_T	$\Phi=90^\circ$ (12 o'clock)	-	85	-	deg	Note2
	θ_B	$\Phi=270^\circ$ (6 o'clock)	-	85	-	deg	Note2
	θ_L	$\Phi=180^\circ$ (9 o'clock)	-	85	-	deg	Note2
	θ_R	$\Phi=0^\circ$ (3 o'clock)	-	85	-	deg	Note2
Response Time	T_{ON}	Normal $\theta=\Phi=0^\circ$	-	15	20	msec	Note4
	T_{OFF}		-	15	20	msec	Note4
Contrast Ratio	CR		500	800	-	-	Note1 Note3
Color Chromaticity	W_X		0.258	0.308	0.358	-	Note1 Note5
	W_Y		0.286	0.336	0.386	-	Note1 Note5
Luminance	L		350	400	-	cd/m ²	Note1 Note7
Luminance Uniformity	Y_U		75	80	-	%	Note1 Note6
NTSC	-		-	50	-	%	-

Note 1:Definition of optical measurement system

The optical characteristics should be measured in dark room. After 5 minutes operation, the optical properties are measured at the center point of the LCD screen. All input terminals LCD panel must be ground when measuring the center area of the panel.

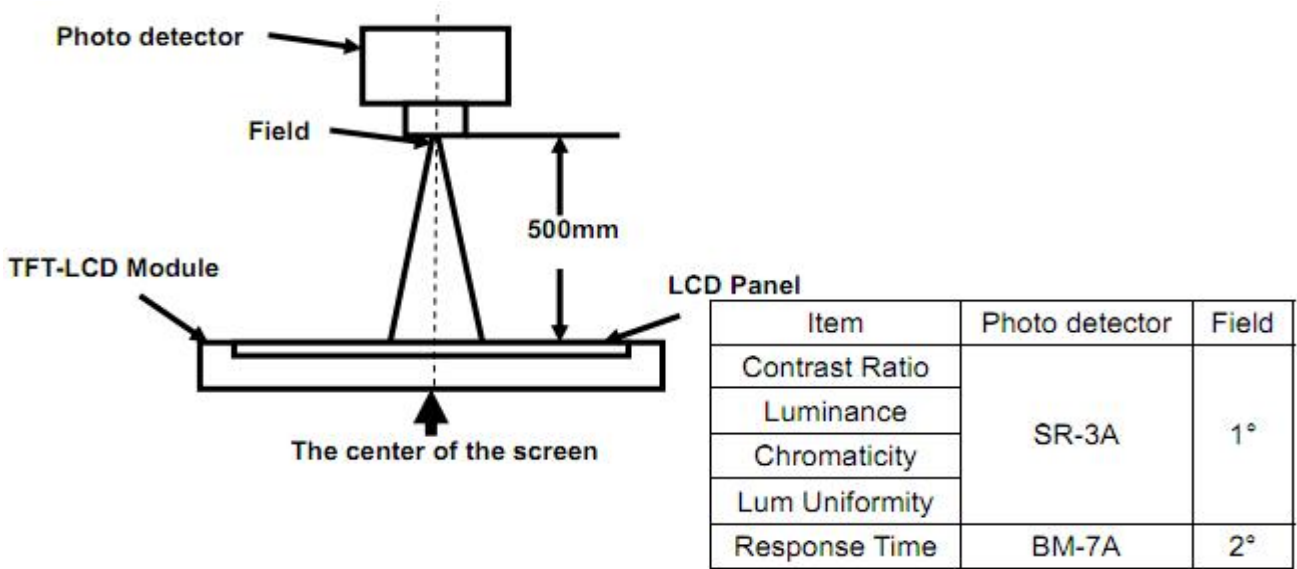

Note 2: Definition of viewing angle range and measurement system
 Viewing angle is measured at the center point of the LCD by CONOSCOPE(ergo-80).

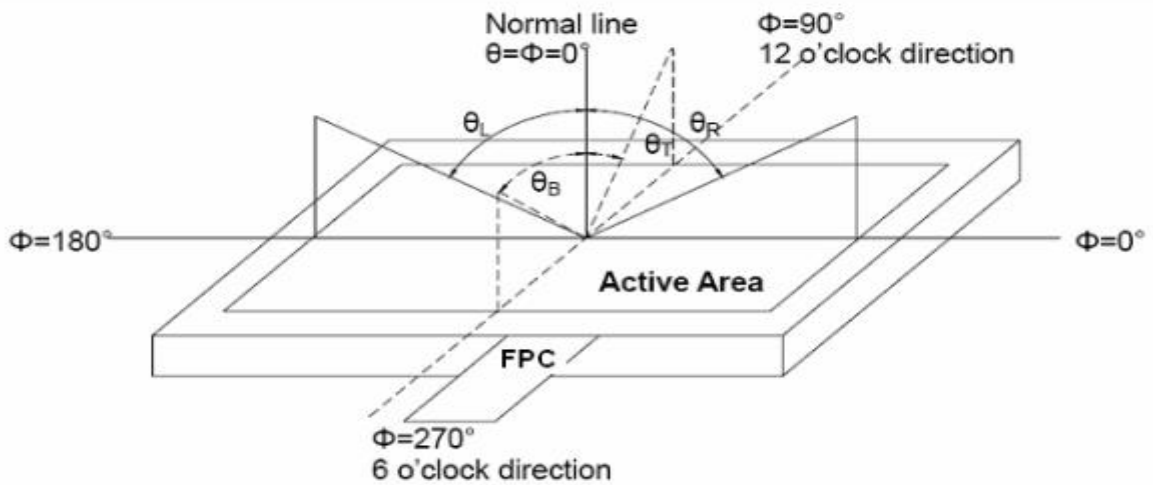

Fig. 1 Definition of viewing angle

Note 3: Definition of contrast ratio

$$CR = \frac{\text{Luminance with all pixels white}}{\text{Luminance with all pixels black}}$$

Note 4: Definition of Response time

The response time is defined as the LCD optical switching time interval between “White” state and “Black”state. Rise time (TON) is the time between photo detector output intensity changed from 90% to 10%. And fall time (TOFF) is the time between photo detector output intensity changed from 10% to 90%.

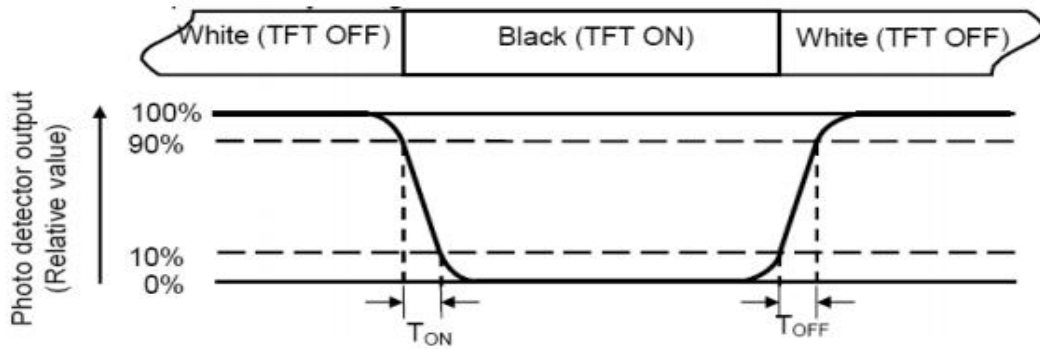

Note 5: Definition of color chromaticity (CIE1931)

Color coordinates measured at center point of LCD.

Note 6: Definition of Luminance Uniformity

The luminance uniformity in surface luminance is determined by measuring luminance at each test position 1 through n, and then dividing the maximum luminance of n points luminance by minimum luminance of n points luminance. For more information see FIG.2.

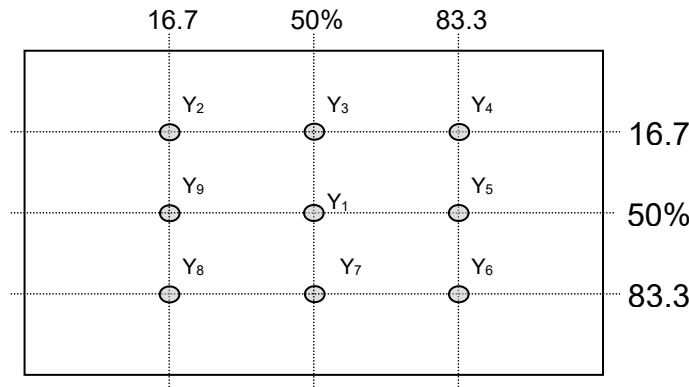

Fig. 2 Definition of points

Note 7: Definition of Luminance (Refer Fig. 2)

Surface luminance is the luminance with all pixels displaying white.

L_v = Average Surface Luminance with all white pixels($P_1, P_2, P_3, \dots, P_n$).

6. Reliability Test Items

Test Item	Test Conditions
High Temperature Storage	Ta= +80°C 96hrs
Low Temperature Storage	Ta= -30°C 96hrs
High Temperature Operation	Ta= +70°C 96hrs
Low Temperature Operation	Ta= -20°C 96hrs
High Temperature and Humidity Storage	Ta= +60°C, 90% RH 96hrs
Thermal Shock (Non-operation)	-30°C/30 min ~ +80°C/30 min for 20 cycles Start with cold temperature end with high temperature
Electro Static Discharge	Contact = ± 4 kV, class B Air = ± 8 kV, class B R=330Ω,C=150pF
Vibration	Sweep: 10Hz~55Hz~10Hz Stroke: 1.5mm 2 hrs for each direction of X .Y. Z.
Mechanical Shock	60G 6ms,±X,±Y,±Z 3 times for each direction
Package Drop Test	Height: 60 cm 1 corner, 3 edges, 6 surfaces

Notes: The test result shall be evaluated after the sample has been left at room temperature and humidity for 2 hours without load. No condensation shall be accepted. The sample will not be accepted if appear these defects:

- 1). Air bubble in the LCD
- 2). Seal leak or Glass crack
- 3). Non display or abnormal display
- 4). Brightness reduction >50%

9. Packing

Packing Method

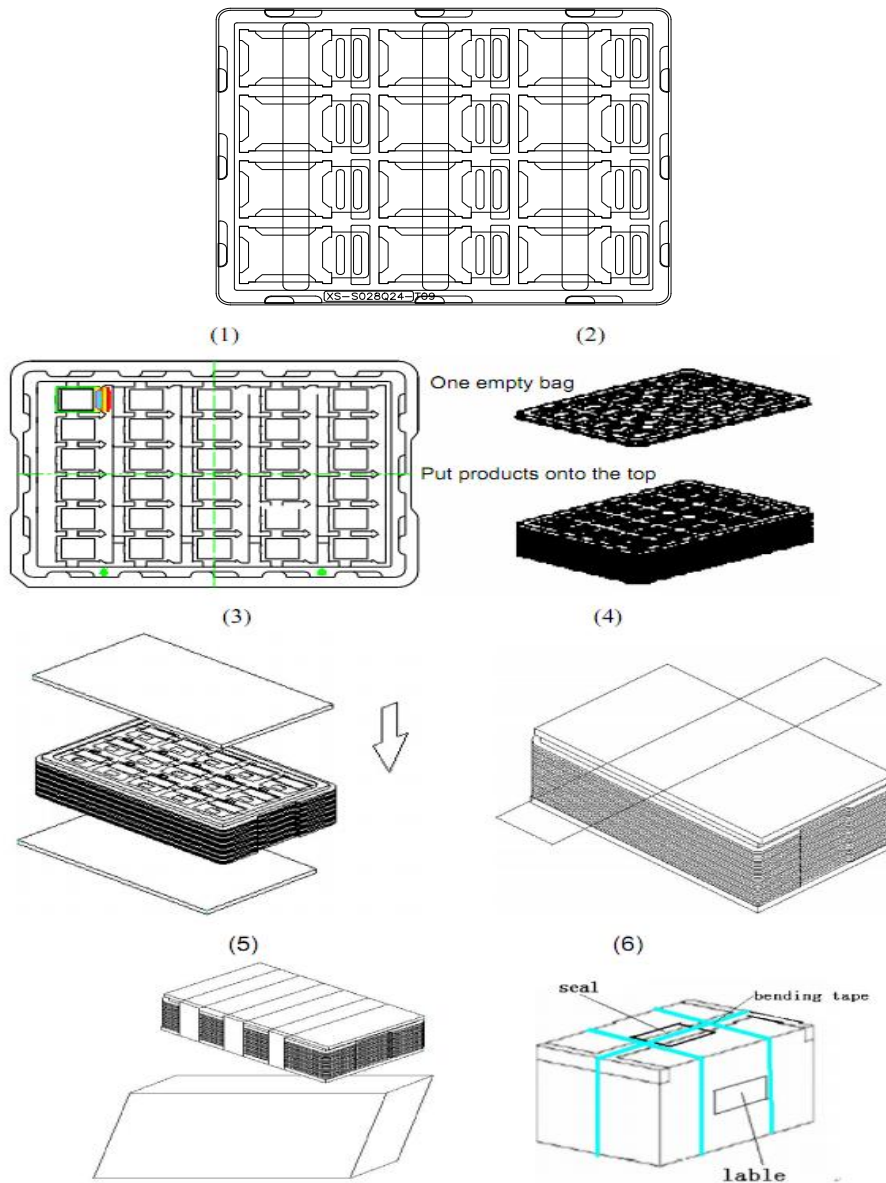

Steps:

1. Put module into tray cavity
2. Tray stacking
3. Put 1 cardboard under the tray stack and 1 cardboard above
4. Fix the cardboard to the tray stack with adhesive tape
5. Put the tray stack into carton
6. Carton sealing with adhesive tape

10. Precautions for Use of LCD modules

10.1 Handling Precautions

10.1.1. The display panel is made of glass. Do not subject it to a mechanical shock by dropping it from a high place, etc.

10.1.2. If the display panel is damaged and the liquid crystal substance inside it leaks out, be sure not to get any in your mouth, if the substance comes into contact with your skin or clothes, promptly wash it off using soap and water.

10.1.3. Do not apply excessive force to the display surface or the adjoining areas since this may cause the color tone to vary.

10.1.4. The polarizer covering the display surface of the LCD module is soft and easily scratched. Handle this polarizer carefully.

10.1.5. If the display surface is contaminated, breathe on the surface and gently wipe it with a soft dry cloth. If still not completely clear, moisten cloth with one of the following solvents:

- Isopropyl alcohol
- Ethyl alcohol

Solvents other than those mentioned above may damage the polarizer. Especially, do not use the following:

- Water
- Ketene
- Aromatic solvents

10.1.6. Do not attempt to disassemble the LCD Module.

10.1.7. If the logic circuit power is off, do not apply the input signals.

10.1.8. To prevent destruction of the elements by static electricity, be careful to maintain an optimum work environment.

10.1.8.1. Be sure to ground the body when handling the LCD Modules.

10.1.8.2. Tools required for assembly, such as soldering irons, must be properly ground.

10.1.8.3. To reduce the amount of static electricity generated, do not conduct assembly and other work under dry conditions.

10.1.8.4. The LCD Module is coated with a film to protect the display surface. Be care when peeling off this protective film since static electricity may be generated.

10.2 Storage Precautions

10.2.1. When storing the LCD modules, avoid exposure to direct sunlight or to the light of fluorescent lamps.

10.2.2. The LCD modules should be stored under the storage temperature range if the LCD modules will be stored for a long time, the recommend condition is :

Temperature : 0°C ~40°C Relatively humidity: ≤80%

10.2.3. The LCD modules should be stored in the room without acid, alkali and harmful gas.

10.3 Transportation Precautions

The LCD modules should be no falling and violent shocking during transportation, and also should avoid excessive press, water, damp and sunshine.