



PRODUCT SPECIFICATION

CDTECH Model: **S050HWV18HS-DC80**

CUSTOMER Model: **-**

Description: **5.0" TFT-LCD Module with CTP**

Version: **2.0**

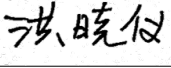
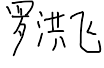
CDTECH	PREPARED BY	CHECKED BY	APPROVED BY
SIGNATURE			
DATE	2022.10.14	2022.10.14	2022.10.14

CUSTOMER APPROVAL	SIGNATURE	DATE



Contents

1. General Specifications	4
2. Absolute Maximum Ratings	5
3. Electrical Characteristics	5
4. Interface Pin Assignment	7
5. Interface Characteristics	8
6. Optical Specifications	14
7. Reliability Test Items	17
8. Mechanical Drawing	18
9. Packing	19
10. Precautions for Use of LCD modules	20

1. General Specifications

1.1 LCM General Information

Item	Specification	Unit
LCD Size	5.0	inch
Number of Pixels	800 (H) RGB x 480 (V)	pixels
Display Mode	Normally Black	-
Viewing Direction	Free	o' clock
Interface	RGB	-
Display Colors	16.7M	colors
Outline Dimension	120.70 (H) x 75.80 (V) x 4.55 (D)	mm
Active Area	108.00 (H) x 64.80 (V)	mm
Pixel Pitch	0.135 (H) x 0.135 (V)	mm
Driver IC	-	-
Operation Temperature	-20~70	°C
Storage Temperature	-30~80	°C

1.2 Touch Panel Information

Item	Specification
Touch Structure	G+G
Bonding Type with LCM	Perimeter Bonding
Driver IC	GT911
Interface	I ² C
Touch Count Max	5 Points
Surface treatment	-
Surface hardness	6H
I2C slave address	0x28
Origin of coordinate	Top Left Corner

Note1:Requirements on environmental protection RoHS compliant.

2. Absolute Maximum Ratings

Item	Symbol	MIN.	MAX.	Unit	Note
Analog Supply voltage	VDD	-0.3	5.0	V	Note 1

Note 1: Permanent damage may occur to the LCD module if beyond this specification.

Functional operation should be restricted to the conditions described under normal operating conditions.

3. Electrical Characteristics

3.1 Recommended Operating Condition for TFT LCD

Item	Symbol	Min.	Typ.	Max.	Unit	Note
Analog Supply voltage	VDD	3.0	3.3	3.6	V	
Analog supply current	I_{VDD}	-	TBD	-	mA	VDD=3.3V
Logic input voltage	V_{IH}	$0.7 \cdot VDD$	-	VDD	V	
	V_{IL}	GND	-	$0.3 \cdot VDD$	V	

3.2 Recommended Driving Condition for Backlight

Item	Symbol	Min.	Typ.	Max.	Unit	Note
Driving Current	I_F	-	40	-	mA	
Driving Voltage	V_F	16.2	-	20.4	V	
Power consumption	W_{BL}	0.648	-	0.816	W	
LED Life-Time	N/A	30,000	-	-	Hours	Ta=25°C Note 1

Note 1: LED lifetime is defined as the module brightness decay 50% of original brightness at Ta=25 degree, typical current.

Note 2: LED circuit :

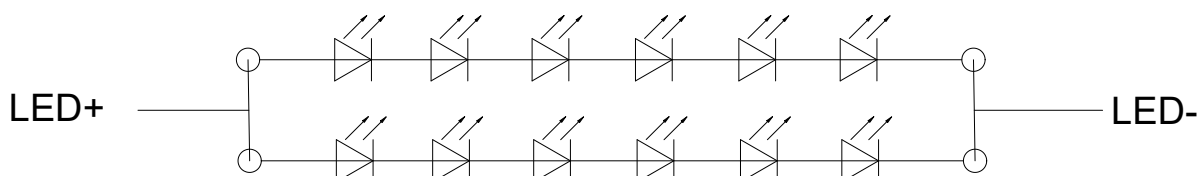

3.3 Touch Panel

Item	Symbol	Min.	Typ.	Max.	Unit	Note
Power Supply voltage	VDD	-	3.3	-	V	
Analog supply current	I _{VDD}	-	TBD	-	mA	VDD=3.3V
Input high-level voltage	V _{IH}	0.7*VDD	-	VDD	V	
Input low -level voltage	V _{IL}	GND	-	0.3*VDD	V	

4. Interface Pin Assignment

4.1 LCM Pin Assignment

Recommended connector: FH12-40S-0.5SH manufactured by HIROSE

No.	Symbol	Description
1	VLED-	Power for LED backlight (Cathode)
2	VLED+	Power for LED backlight (Anode)
3	GND	Ground
4	VDD	Power supply
5-12	R0-R7	Data bus
13-20	G0-G7	Data bus
21-28	B0-B7	Data bus
29	GND	Ground
30	DCLK	Dot clock signal input. Latching input data at its rising edge.
31	DISP	Standby mode. Normally pulled high DISP="1": Normally operation (Default) DISP="0": Timing controller, source driver will turn off ,all output are High-Z
32	HSYNC	Horizontal Sync signal
33	VSYNC	Vrtical Sync signal
34	DE	Data enable input. Active high to enable the input data bus under "DE Mode"
35	NC	No connection
36	GND	Ground
37	NC/XR	No connection
38	NC/YD	No connection
39	NC/XL	No connection
40	NC/YU	No connection

4.2 Touch FPC Pin Assignment

Recommended connector: FH12-6S-0.5SH manufactured by HIROSE

No.	Symbol	Description
1	RST	Reset Pin for CTP
2	VDD (3.3V)	Power Supply (3.3V)
3	GND	Ground
4	INT(1.8V)	Interrupt signal from CTP(1.8V)
5	SDA	I2C data input and output
6	SCL	I2C clock input

5. Interface Characteristics

5.1 System Bus Timing for RGB Interface

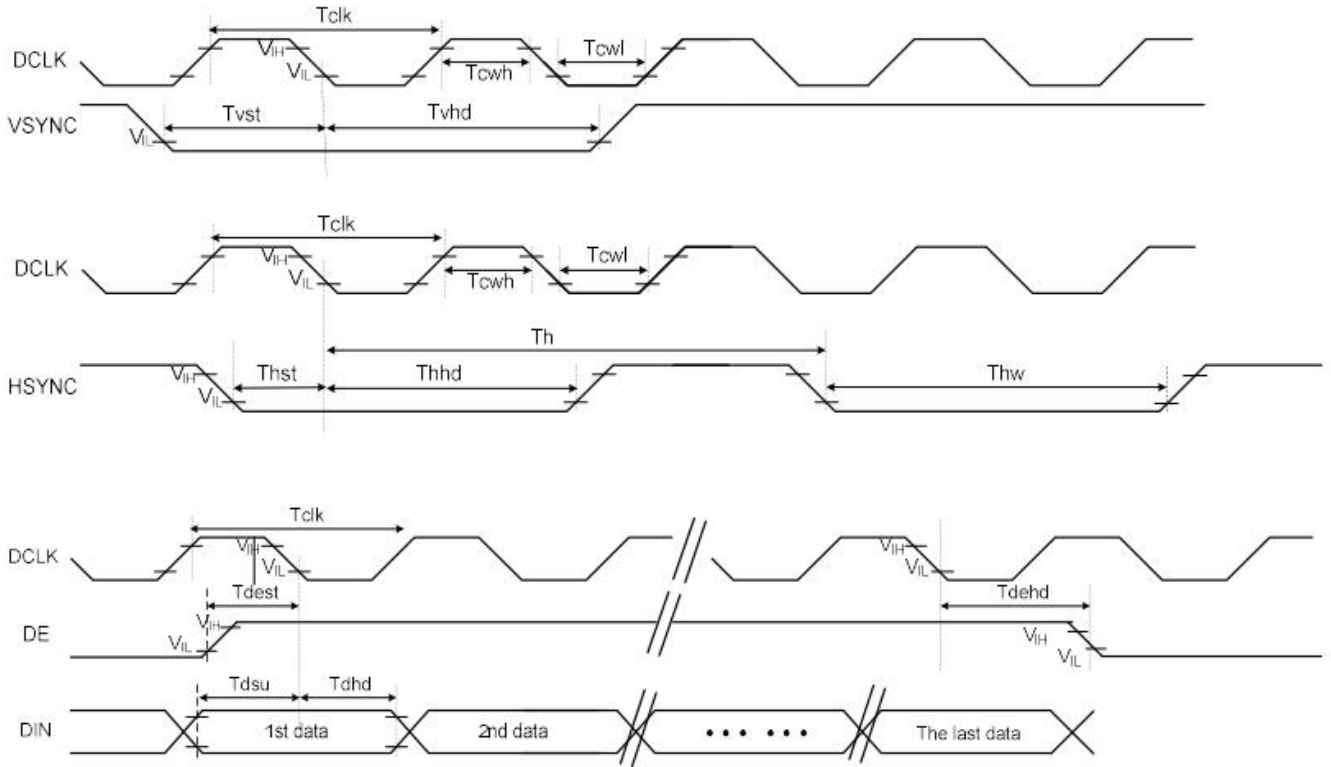

Item	Symbol	Min.	Typ.	Max.	Unit	Conditions
CLK Pulse Duty	Tcw	40	50	60	%	
HSYNC Width	Thw	2	-	-	DCLK	
HSYNC Period	Th	55	60	65	us	
VSYNC Setup Time	Tvst	12	-	-	ns	
VSYNC Hold Time	Tvhd	12	-	-	ns	
HSYNC Setup Time	Thst	12	-	-	ns	
HSYNC Hold Time	Thhd	12	-	-	ns	
Data Setup Time	Tdsu	12	-	-	ns	
Data Hold Time	Tdhd	12	-	-	ns	
DE Setup Time	Tdest	12	-	-	ns	
DE Hold Time	Tdehd	12	-	-	ns	

5.2 Power On Sequence

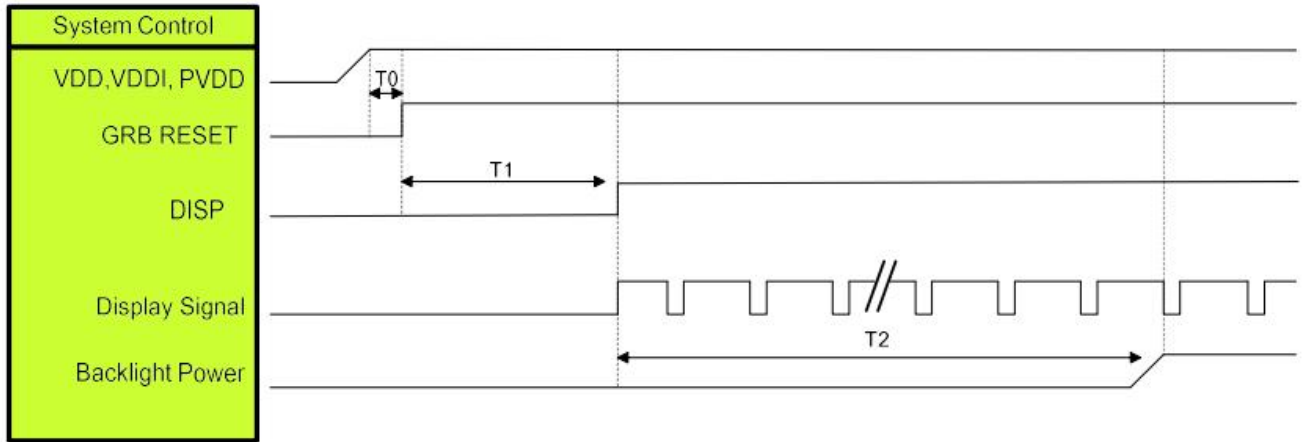

Symbol	Description	Min. Time	Unit
T0	System power stability to GRB RESET signal	0	ms
T1	GRB RESET= "High" to DISP="High"	10	ms
T2	Display Signal output to Backlight Power on	250	ms

5.3 Power Off Sequence

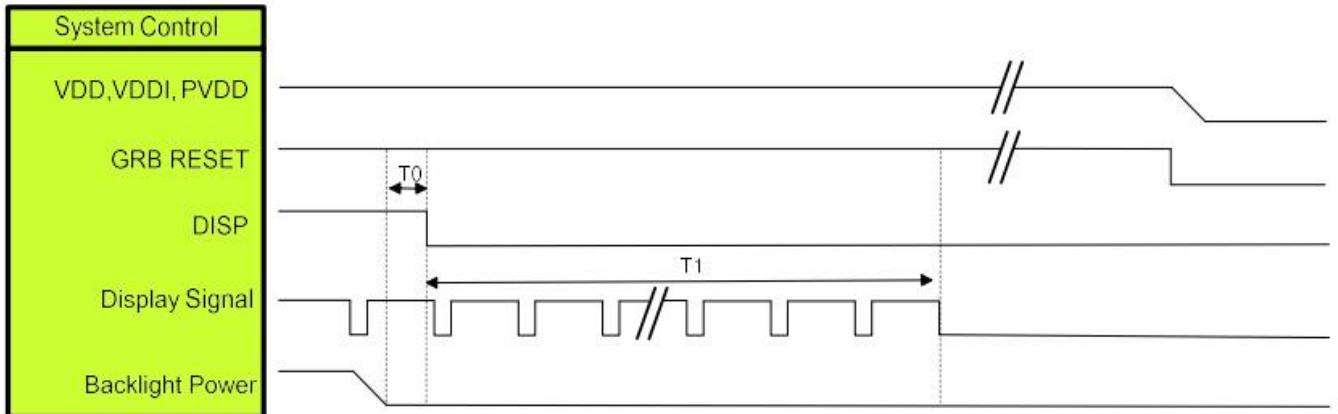

Symbol	Description	Min. Time	Unit
T0	Backlight Power off to DISP="Low"	5	ms
T1	DISP="Low" to IC internal voltage discharge complete	80	ms

5.4 RGB Interface

5.4.1 SYNC Mode

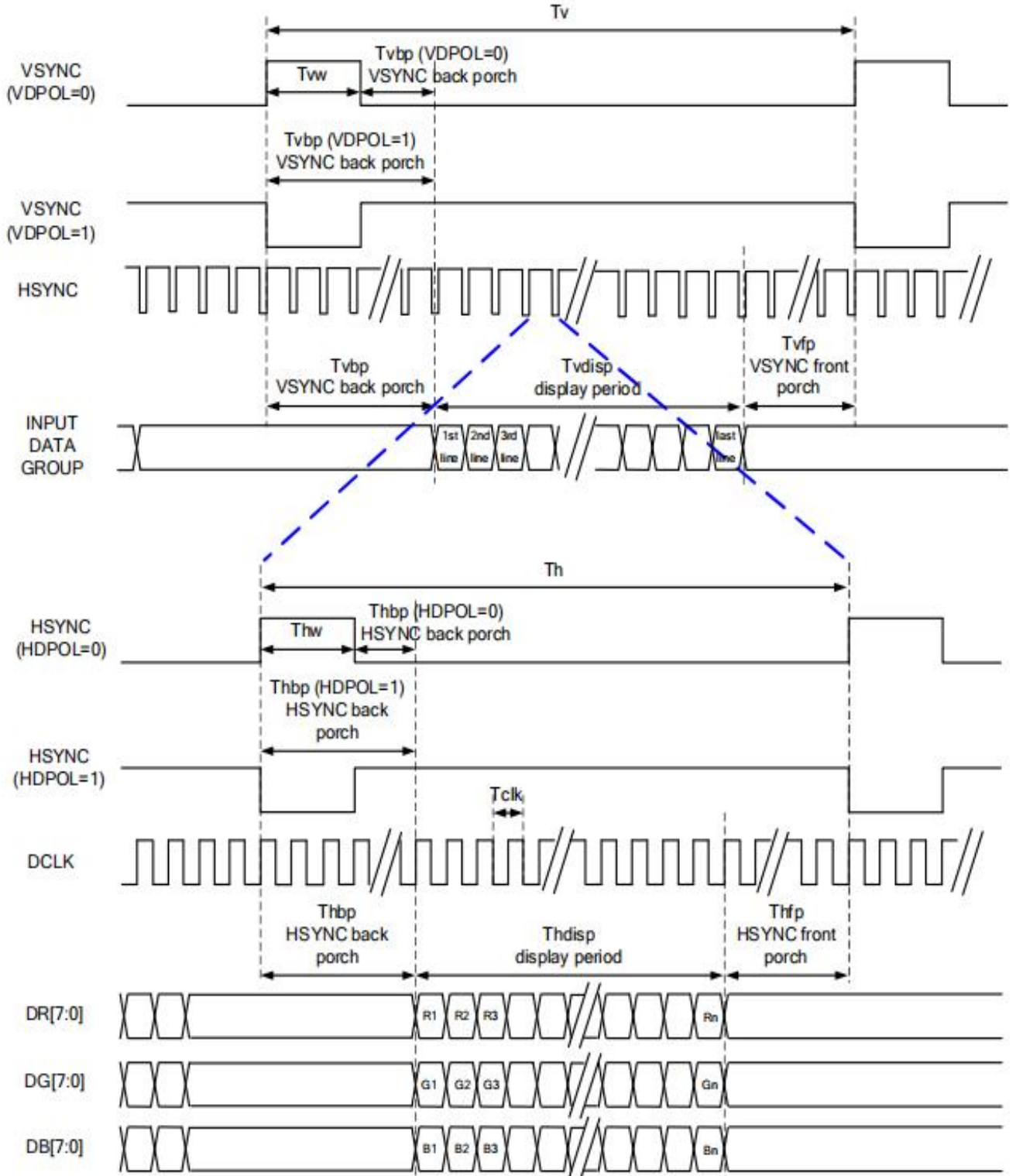

5.4.2 SYNC-DE Mode

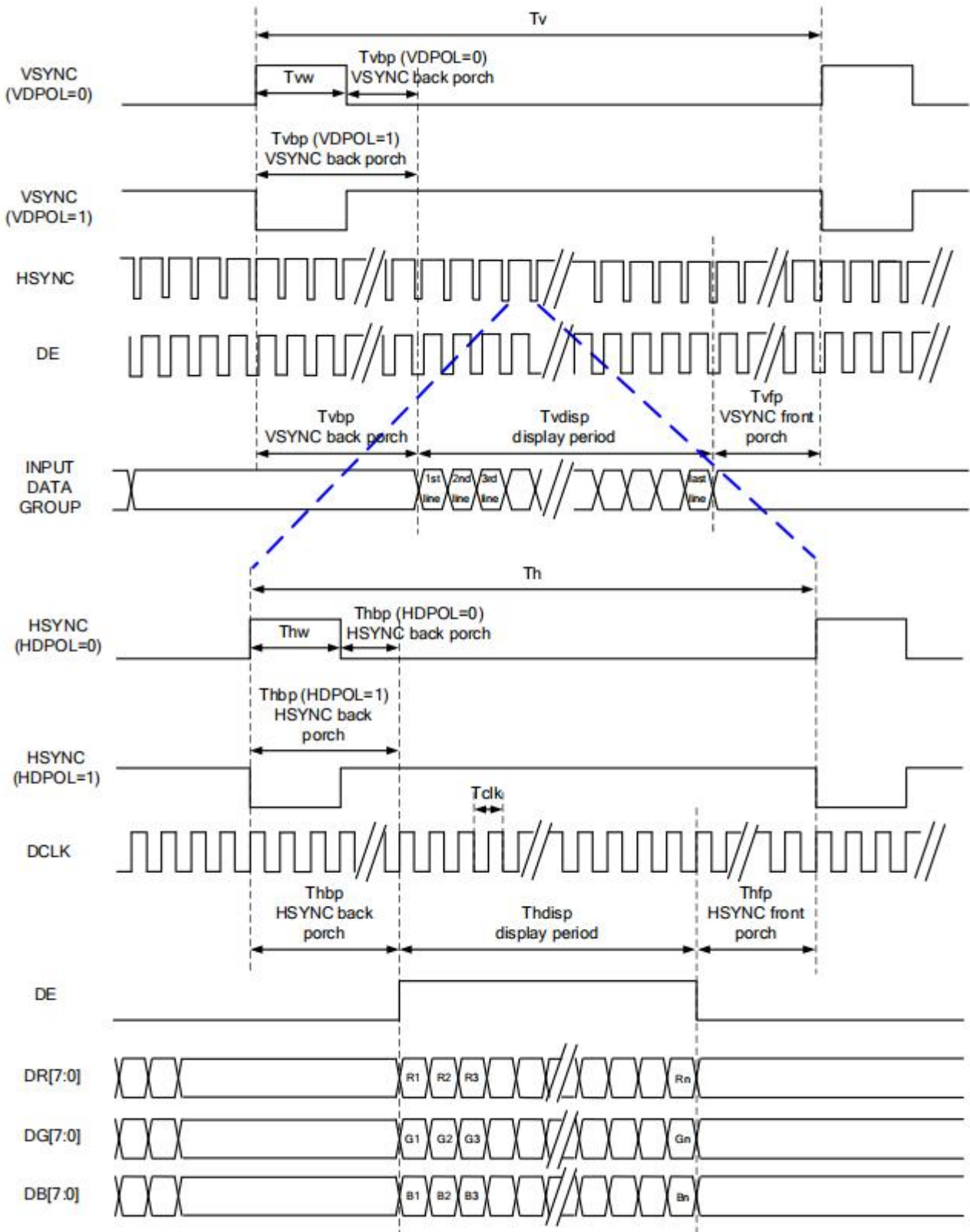

5.4.3 DE Mode

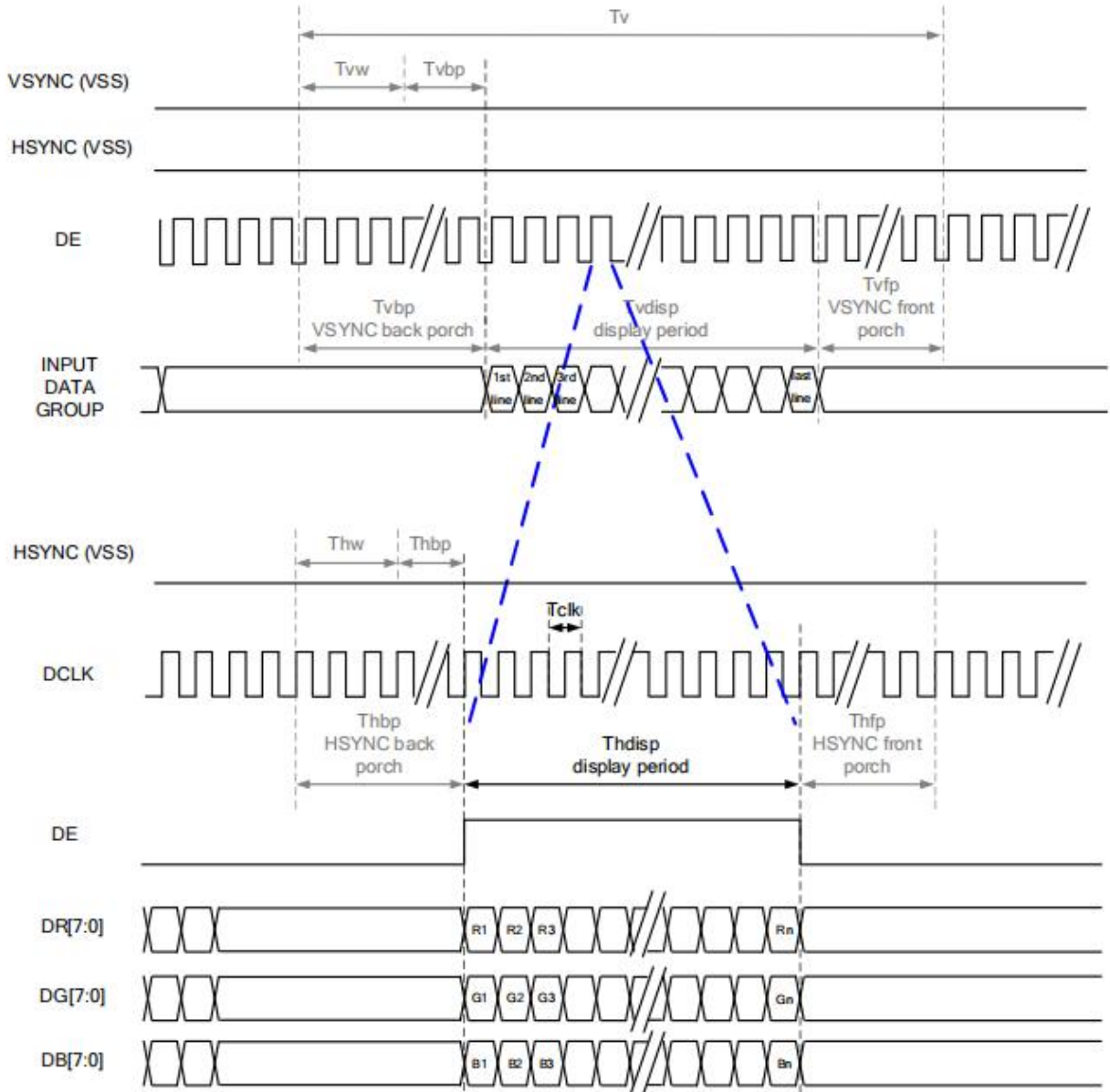

RGB Mode Selection Table	DCLK	HSYNC	VSYNC	DE
SYNC - DE Mode	Input	Input	Input	Input
SYNC Mode	Input	Input	Input	GND
DE Mode	Input	GND	GND	Input

Note: "Input" means these signals are driven by host side.

5.4.4 Parallel 24-bit RGB Input Timing

Parallel 24-bit RGB Input Timing (PVDD=PVDD1=VDD=VDDI= 3.3V, AGND= 0V, TA=25°C)

Parallel 24-bit RGB Interface Timing Table							
Item	Symbol	Min.	Typ.	Max.	Unit	Remark	
DCLK Frequency	Fclk	23	25	27	MHz		
HSYNC	Period Time	Th	-	816	896	DCLK	
	Display Period	Thdisp	800			DCLK	
	Back Porch	Thbp	-	8	48	DCLK	
	Front Porch	Thfp	-	8	48	DCLK	
	Pulse Width	Thw	-	4	8	DCLK	
VSYNC	Period Time	Tv	-	496	504	HSYNC	
	Display Period	Tvdisp	480			HSYNC	
	Back Porch	Tvbp	-	8	12	HSYNC	
	Front Porch	Tvfp	-	8	12	HSYNC	
	Pulse Width	Tvw	-	4	8	HSYNC	

6. Optical Specifications

Item	Symbol	Condition	Min.	Typ.	Max.	Unit	Note
Viewing Angle (CR≥10) B/L ON	θ_T	$\Phi=90^\circ$ (12 o'clock)	70	80	-	deg	Note2
	θ_B	$\Phi=270^\circ$ (6 o'clock)	70	80	-	deg	Note2
	θ_L	$\Phi=180^\circ$ (9 o'clock)	70	80	-	deg	Note2
	θ_R	$\Phi=0^\circ$ (3 o'clock)	70	80	-	deg	Note2
Response Time	T_{ON}	Normal $\theta=\Phi=0^\circ$	-	15	20	msec	Note4
	T_{OFF}		-	15	20	msec	Note4
Contrast Ratio	CR		800	1000	-	-	Note1 Note3
Color Chromaticity	W_X		0.315	0.345	0.375	-	Note1 Note5
	W_Y		0.335	0.365	0.395	-	Note1 Note5
Luminance	L		350	400	-	cd/m ²	Note1 Note7
Luminance Uniformity	Y_U		75	80	-	%	Note1 Note6
NTSC	-		45	50	-	%	-

Note 1: Definition of optical measurement system

The optical characteristics should be measured in dark room. After 5 minutes operation, the optical properties are measured at the center point of the LCD screen. All input terminals LCD panel must be ground when measuring the center area of the panel.

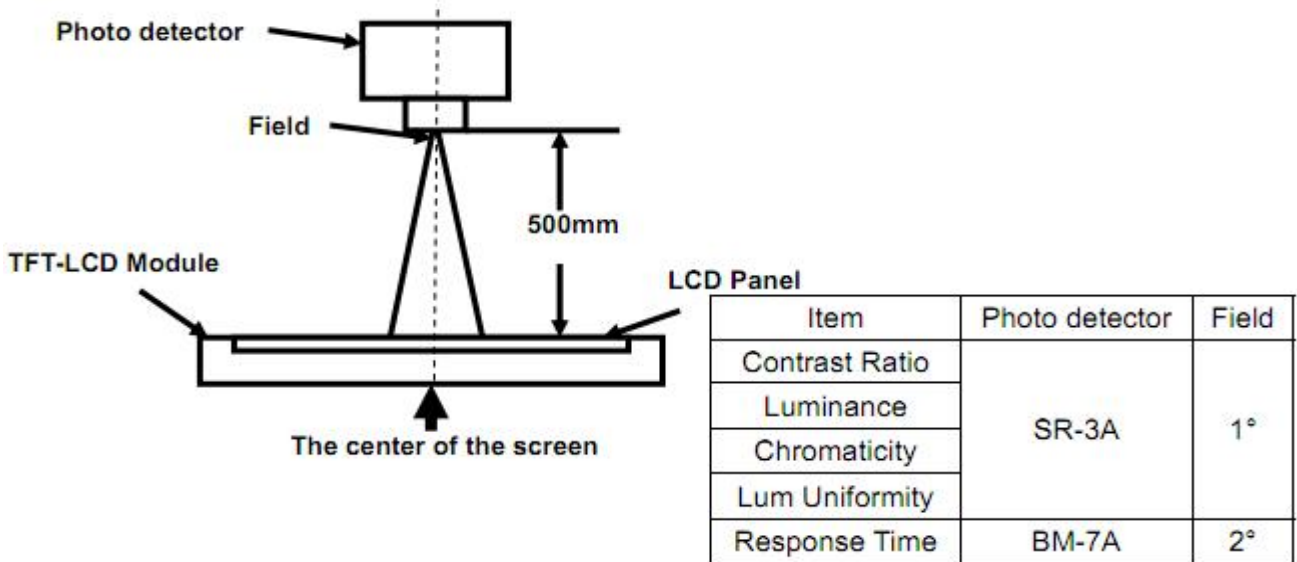

Note 2: Definition of viewing angle range and measurement system

Viewing angle is measured at the center point of the LCD by CONOSCOPE(ergo-80).

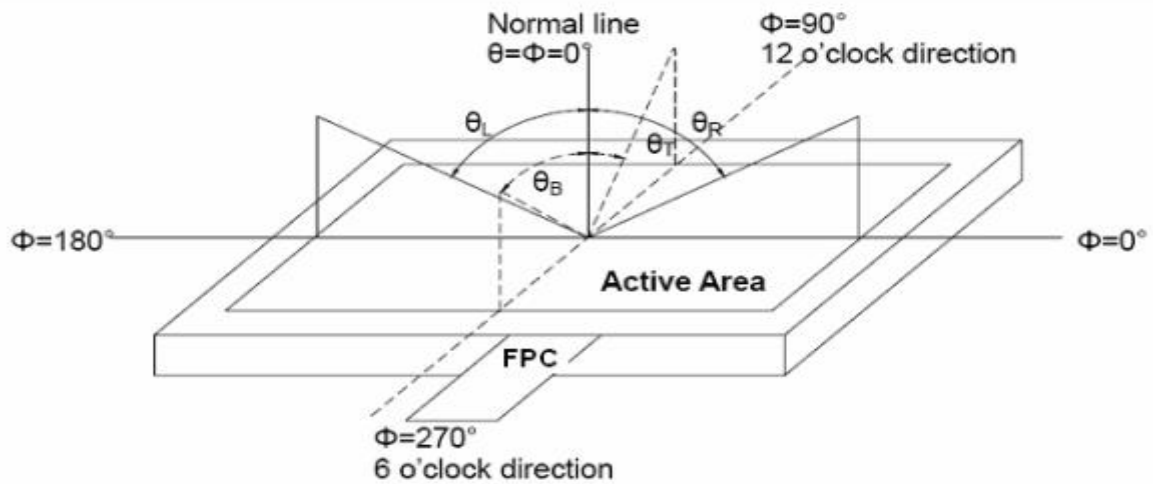

Fig. 1 Definition of viewing angle

Note 3: Definition of contrast ratio

$$CR = \frac{\text{Luminance with all pixels white}}{\text{Luminance with all pixels black}}$$

Note 4: Definition of Response time

The response time is defined as the LCD optical switching time interval between “White” state and “Black”state. Rise time (TON) is the time between photo detector output intensity changed from 90% to 10%. And fall time (TOFF) is the time between photo detector output intensity changed from 10% to 90%.

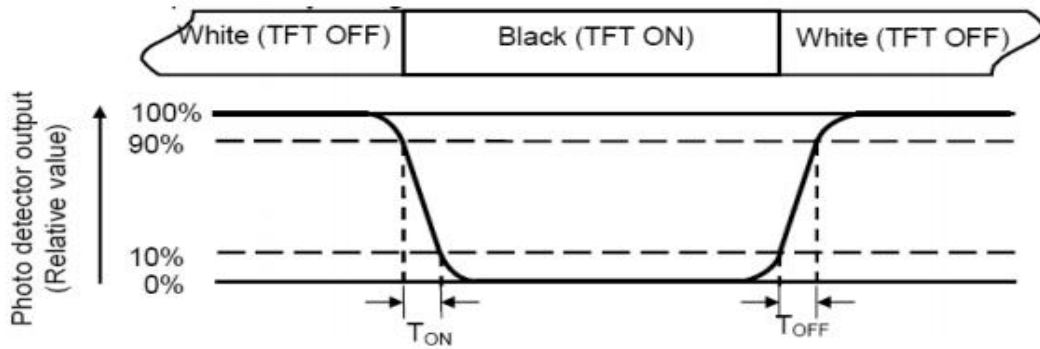

Note 5: Definition of color chromaticity (CIE1931)

Color coordinates measured at center point of LCD.

Note 6: Definition of Luminance Uniformity

The luminance uniformity in surface luminance is determined by measuring luminance at each test position 1 through n, and then dividing the maximum luminance of n points luminance by minimum luminance of n points luminance. For more information see FIG.2.

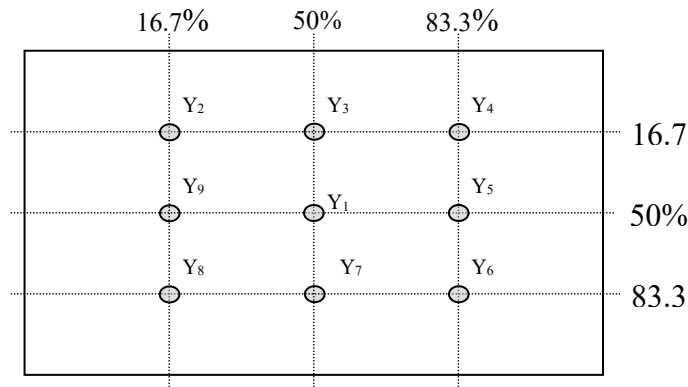

Fig. 2 Definition of points

Note 7: Definition of Luminance (Refer Fig. 2)

Surface luminance is the luminance with all pixels displaying white.

$L_v = \text{Average Surface Luminance with all white pixels}(P_1, P_2, P_3, \dots, P_n)$.

7. Reliability Test Items

Test Item	Test Conditions
High Temperature Storage	Ta= +80°C 96hrs
Low Temperature Storage	Ta= -30°C 96hrs
High Temperature Operation	Ta= +70°C 96hrs
Low Temperature Operation	Ta= -20°C 96hrs
High Temperature and Humidity Storage	Ta= +60°C, 90% RH 96hrs
Thermal Shock (Non-operation)	-30°C/30 min ~ +80°C/30 min for 20 cycles Start with cold temperature end with high temperature
Electro Static Discharge	Contact = ± 4 kV, class B Air = ± 8 kV, class B R=330Ω,C=150pF
Vibration	Sweep: 10Hz~55Hz~10Hz Stroke: 1.5mm 2 hrs for each direction of X .Y. Z.
Mechanical Shock	60G 6ms,±X,±Y,±Z 3 times for each direction
Package Drop Test	Height: 60 cm 1 corner, 3 edges, 6 surfaces

Notes: The test result shall be evaluated after the sample has been left at room temperature and humidity for 2 hours without load. No condensation shall be accepted. The sample will not be accepted if appear these defects:

- 1). Air bubble in the LCD
- 2). Seal leak or Glass crack
- 3). Non display or abnormal display
- 4). Brightness reduction >50%

9. Packing

Packing Method

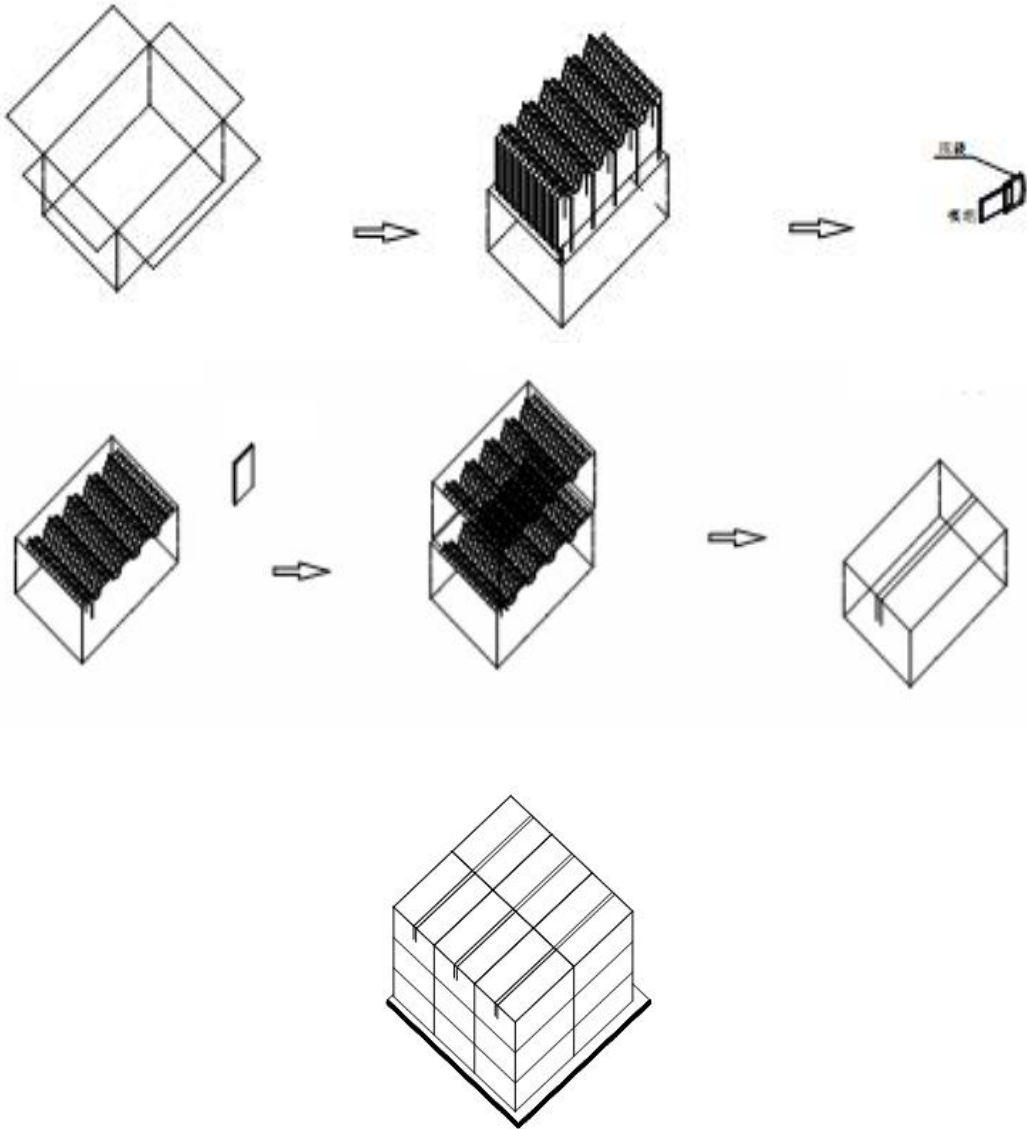

10. Precautions for Use of LCD modules

10.1 Handling Precautions

10.1.1. The display panel is made of glass. Do not subject it to a mechanical shock by dropping it from a high place, etc.

10.1.2. If the display panel is damaged and the liquid crystal substance inside it leaks out, be sure not to get any in your mouth, if the substance comes into contact with your skin or clothes, promptly wash it off using soap and water.

10.1.3. Do not apply excessive force to the display surface or the adjoining areas since this may cause the color tone to vary.

10.1.4. The polarizer covering the display surface of the LCD module is soft and easily scratched. Handle this polarizer carefully.

10.1.5. If the display surface is contaminated, breathe on the surface and gently wipe it with a soft dry cloth. If still not completely clear, moisten cloth with one of the following solvents:

- Isopropyl alcohol
- Ethyl alcohol

Solvents other than those mentioned above may damage the polarizer. Especially, do not use the following:

- Water
- Ketene
- Aromatic solvents

10.1.6. Do not attempt to disassemble the LCD Module.

10.1.7. If the logic circuit power is off, do not apply the input signals.

10.1.8. To prevent destruction of the elements by static electricity, be careful to maintain an optimum work environment.

10.1.8.1. Be sure to ground the body when handling the LCD Modules.

10.1.8.2. Tools required for assembly, such as soldering irons, must be properly ground.

10.1.8.3. To reduce the amount of static electricity generated, do not conduct assembly and other work under dry conditions.

10.1.8.4. The LCD Module is coated with a film to protect the display surface. Be care when peeling off this protective film since static electricity may be generated.

10.2 Storage Precautions

10.2.1. When storing the LCD modules, avoid exposure to direct sunlight or to the light of fluorescent lamps.

10.2.2. The LCD modules should be stored under the storage temperature range if the LCD modules will be stored for a long time, the recommend condition is :

Temperature : 0°C ~40°C Relatively humidity: ≤80%

10.2.3. The LCD modules should be stored in the room without acid, alkali and harmful gas.

10.3 Transportation Precautions

The LCD modules should be no falling and violent shocking during transportation, and also should avoid excessive press, water, damp and sunshine.