



# CDTech(H.K.)Electronics Limited

## Product Specification

<b>Model Name</b>	S070SWV49EG
<b>Description</b>	Standard LCD Module 7.0" WVGA 800(RGB)x480 Dots
<b>Date</b>	2018/12/12
<b>Version</b>	1.0

<b>Approved by/Date</b>	<b>Check by/Date</b>	<b>Prepared by/Date</b>
ZHP 2018/12/12	HZX 2018/12/12	YiGui Hang 2018/12/12

<b>Customer Approval</b>	
<b>Date</b>	



# CDTech(H.K.)Electronics Limited

## Table of Contents

<b>1. Record of Revision .....</b>	<b>3</b>
<b>2. General Specifications .....</b>	<b>4</b>
<b>3. Input/Output Terminals .....</b>	<b>5</b>
<b>4. Absolute Maximum Rating .....</b>	<b>7</b>
<b>5. Electrical Characteristics.....</b>	<b>8</b>
<b>6. Interface Timing.....</b>	<b>10</b>
<b>7. Optical Characteristics .....</b>	<b>11</b>
<b>8. Environmental / Reliability Tests .....</b>	<b>14</b>
<b>9. Mechanical Drawing .....</b>	<b>16</b>
<b>10. Packing .....</b>	<b>17</b>
<b>11. Precautions for Use of LCD modules .....</b>	<b>18</b>

## 1. Record of Revision

Rev	Issued Date	Description	Editor
1.0	2018/12/12	First Release.	YiGui Hang

## 2. General Specifications

	Feature	Spec
Characteristics	Size	7 inch
	Resolution	800(horizontal)*480(Vertical)
	Interface	24-bit RGB
	Connect type	Connector
	Display Colors	16.7M
	Technology type	a-Si
	Pixel pitch (mm)	0.192*0.179
	Pixel Configuration	R.G.B.-Stripe
	Display Mode	Normally White
	LCD Driver IC	TBD
	Viewing Direction	12 O'clock
	Gray Inversion Direction	6 O'clock
Mechanical	LCM (W x H x D) (mm)	164.9*100.0*5.7
	Active Area(mm)	154.08 x 85.92
	With /Without TSP	Without TSP
	Weight (g)	TBD
	LED Numbers	27 LEDs

Note 1: Requirements on Environmental Protection: RoHs

Note 2: LCM weight tolerance: +/- 5%

## 3. Input/Output Terminals

### LCD PIN-MAP

No.	Symbol	Description
1, 2	VLED+	Power for LED backlight (Anode)
3, 4	VLED-	Power for LED backlight (Cathode)
5	GND	Power Ground
6	VCOM	Common voltage
7	DVDD	Power for Digital Circuit
8	MODE	DE/SYNC mode select <span style="float: right;">Note1</span>
9	DE	Data Enable
10	VS	Vertical sync signal
11	HS	Horizontal sync Signal
12	B7	Blue data(MSB)
13	B6	Blue data
14	B5	Blue data
15	B4	Blue data
16	B3	Blue data
17	B2	Blue data
18	B1	Blue data <span style="float: right;">Note2</span>
19	B0	Blue data(LSB) <span style="float: right;">Note2</span>
20	G7	Green data(MSB)
21	G6	Green data
22	G5	Green data
23	G4	Green data
24	G3	Green data
25	G2	Green data
26	G1	Green data <span style="float: right;">Note2</span>
27	G0	Green data (LSB) <span style="float: right;">Note2</span>
28	R7	Red Data(MSB) <span style="float: right;">Note2</span>
29	R6	Red Data
30	R5	Red Data
31	R4	Red Data
32	R3	Red Data
33	R2	Red Data

34	R1	Red Data	Note2
35	R0	Red Data(LSB)	Note2
36	GND	Power Ground	
37	DCLK	Pixel clock	Note3
38	GND	Power Ground	
39	L/R	Left/right selection	Note4/5
40	U/D	up/down selection	Note4/5
41	VGH	Gate ON Voltage	
42	VGL	Gate OFF Voltage	
43	AVDD	Power for Analog Circuit	
44	RESET	Global reset pin	Note6
45	NC	NO connection	
46	Vcom	Common Voltage	
47	DITHB	Dithering function	Note7
48	GND	Power Ground	
49	NC	NO connection	
50	NC	NO connection	

**Note 1:** DE/SYNC mode select. Normally pull high.

When select DE mode, MODE="1", VS and HS must pull high.

When select SYNC mode, MODE="0", DE must be grounded.

**Note 2:** When input 18 bits RGB data, the two low bits of R,G and B data must be grounded.

**Note 3:** Data shall be latched at the falling edge of DCLK.

**Note 4:** Selection of scanning mode

Setting of scan control input		Scanning direction
U/D	L/R	
GND	DV <sub>DD</sub>	Up to down, left to right
DV <sub>DD</sub>	GND	Down to up, right to left
GND	GND	Up to down, right to left
DV <sub>DD</sub>	DV <sub>DD</sub>	Down to up, left to right

**Note 5:** Definition of scanning direction.

Refer to the figure as below:

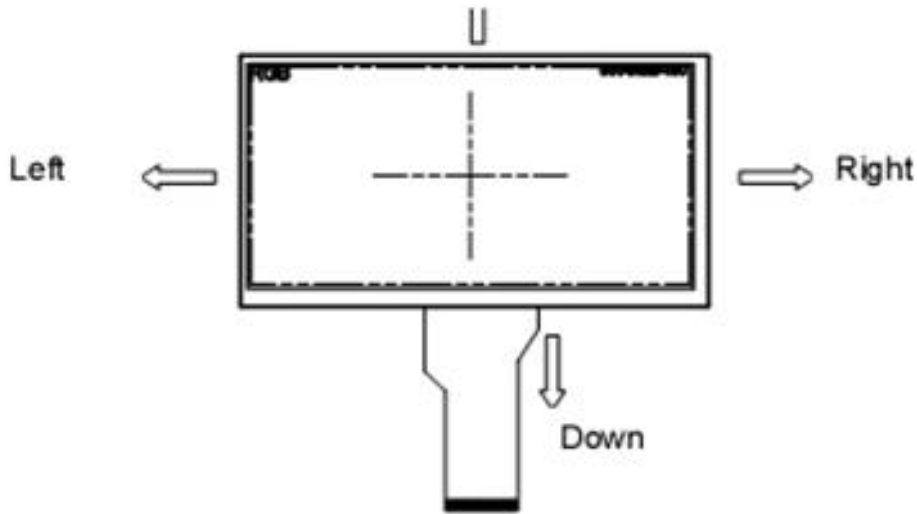

Note 6: Global reset pin. Active low to enter reset state. Suggest to connect with an RC reset circuit for stability. Normally pull high.

Note 7: Dithering function enable control, normally pull high.  
 When DITHB="1", Disable internal dithering function,  
 When DITHB="0", Enable internal dithering function,

Note 8: Reserve for LED power input.

## 4. Absolute Maximum Rating

Item	Symbol	MIN	Typ	MAX	Unit	Remark
Supply Voltage	VDD	-0.3	-	5.0	V	-
Operating Temperature	TOPR	-20	-	70	°C	-
Storage Temperature	TSTG	-30	-	80	°C	-

## 5. Electrical Characteristics

### 5.1 Driving TFT LCD Panel

Item	Symbol	MIN	TYP	MAX	Unit	Remark
Power voltage	V <sub>DD</sub>	3.0	3.3	3.6	V	
	AVDD	10.2	10.4	10.6	V	
	VGH	15.3	16.0	16.7	V	
	VGL	-7.7	-7	-6.3	V	
Input signal voltage	VCOM	2.8	(3.3)	4.8	V	
Operating Temperature	T <sub>OPR</sub>	-20	-	70	°C	
Storage Temperature	T <sub>STG</sub>	-30	-	80	°C	

### 5.3 LED Driving Conditions

Item	Symbol	MIN	TYP	MAX	Unit	Remark
Forward Current	I <sub>F</sub>	-	270	-	m A	
Forward Voltage	V <sub>F</sub>	8.4	9.6	10.8	V	
Backlight Power consumption	W <sub>BL</sub>	2.268	2.592	2.916	W	
LED Lifetime		-	30000	-	Hr s	

Note 1: Each LED: I<sub>F</sub> =30 mA, V<sub>F</sub> =3.2+/-0.2V.

Note 2: Optical performance should be evaluated at Ta=25°C only.

Note 3: If LED is driven by high current, high ambient temperature & humidity condition. The life Time of LED will be reduced. Operating life means brightness goes down to 50% initial brightness.

Typical operating life time is estimated data.

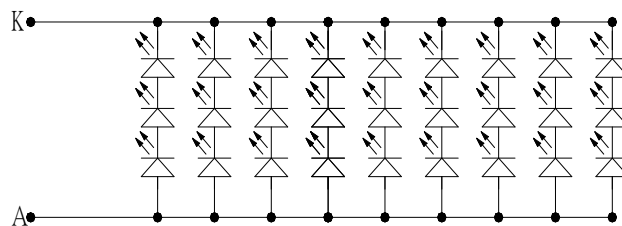

Backlight Circuit diagram



## 6.Interface Timing

### 6.1 Timing

Item	Symbol	Min.	Typ.	Max.	Unit	Note
DCLK cycle time	Tcph	25			ns	
DCLK frequency	fclk		30	40	MHz	
DCLK pulse duty	Tcwh	40	50	60	%	
VSD setup time	Tvst	8			ns	
VSD hold time	Tvhd	8			ns	
HSD setup time	Thst	8			ns	
HSD hold time	Thhd	8			ns	
Data setup time	Tdsu	8			ns	
Data hold time	Tdhd	8			ns	
DE setup time	Tesu	8			ns	
DE hold time	Tehd	8			ns	
Horizontal display area	thd		800		Tcph	
HSD period time	th		928		Tcph	
HSD pulse width	thpw	1	48		Tcph	
HSD back porch	thb		40		Tcph	
HSD front porch	thfp		40		Tcph	
Vertical display area	tvd		480		th	
VSD period time	tv		525		th	
VSD pulse width	tvpw		3		th	
VSD back porch	tvb		29		th	
VSD front porch	tvfp		13		th	

## 6.2 Timing Diagram of Interface Signal

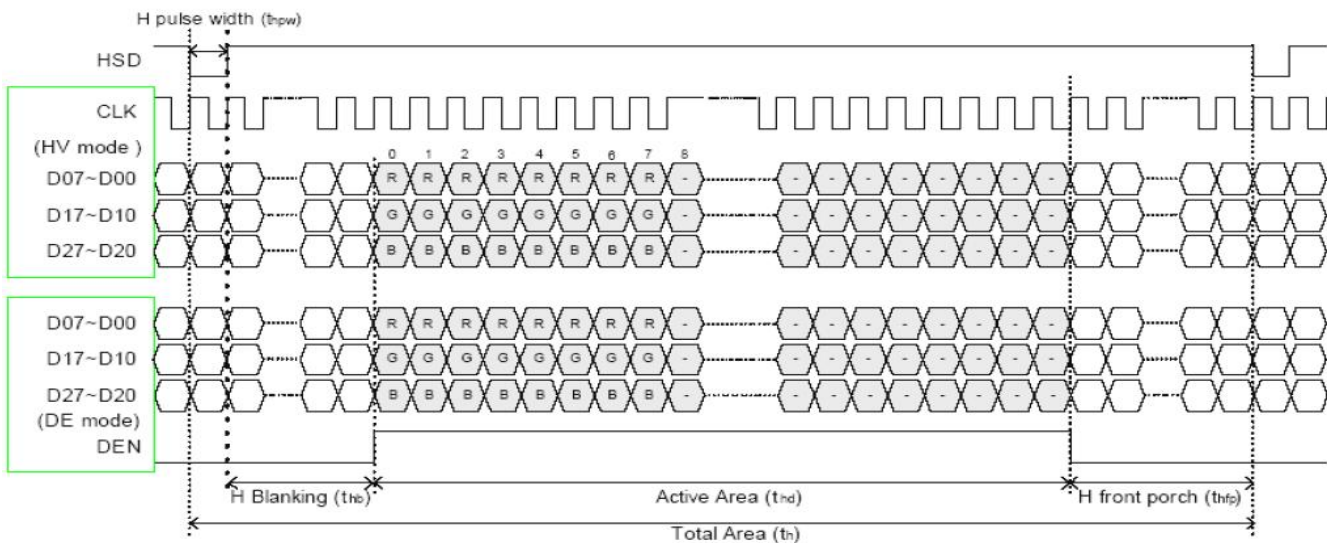
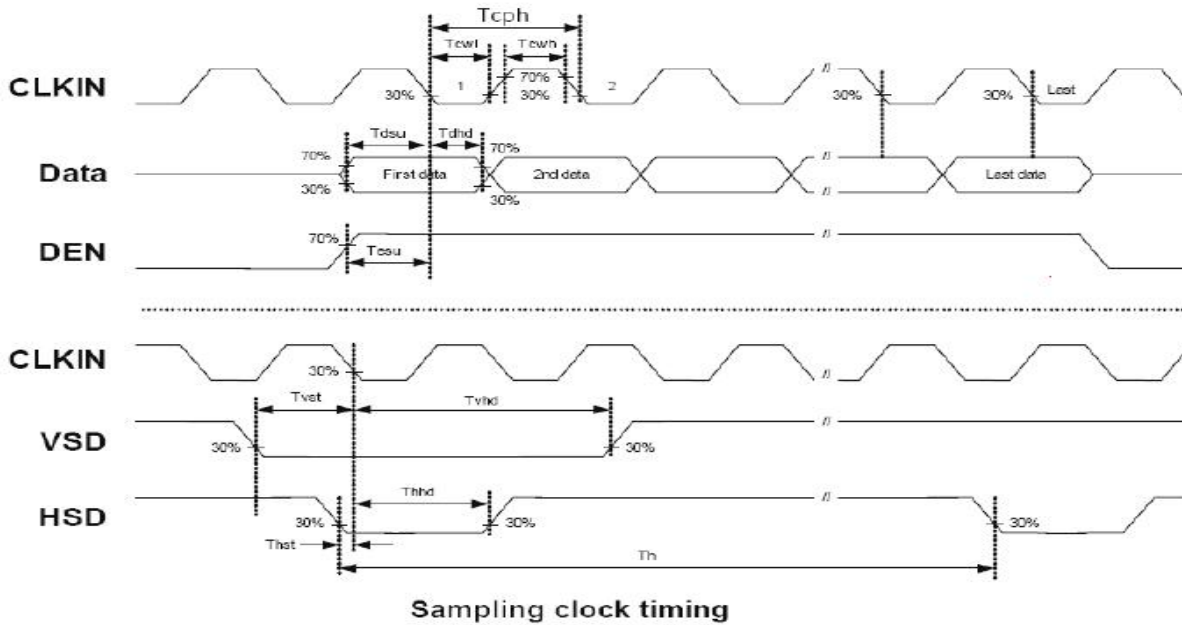

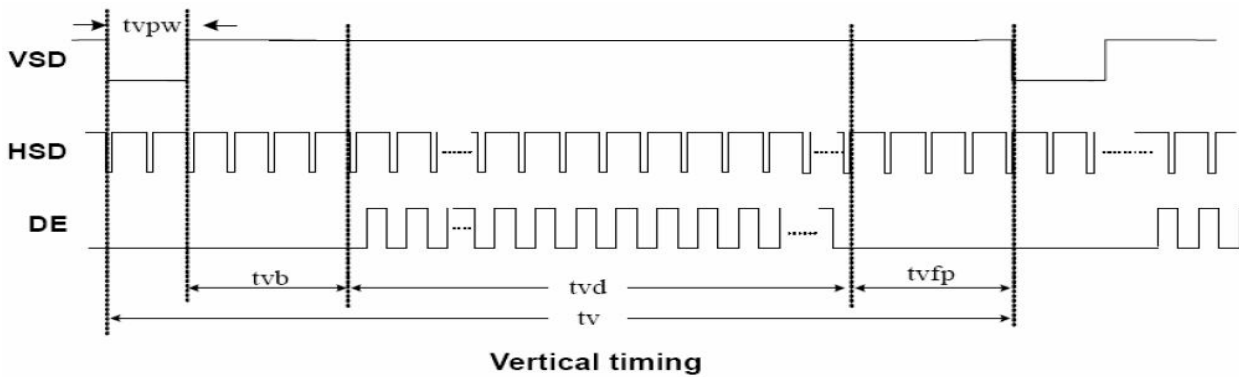

**6.3**

## 7.Optical Characteristics

Items	Symbol	Condition	Min.	Typ.	Max.	Unit	Remark	Note	
Response time	Tr+Tf	-	-	25	35	ms	FIG.1	Note4	
Contrast Ratio	CR	-	400	500	-	-	FIG.2	Note1	
Surface luminance	LV	$\theta = 0^\circ$	-	1000	-	cd/m2	FIG.2	Note2	
Luminance uniformity	Yu	$\theta = 0^\circ$	-	70	-	%	FIG.2	Note3	
NTSC	-	$\theta = 0^\circ$	-	50	-	%	FIG.2	Note5	
Viewing angle	$\theta_T$	Center CR $\geq$ 10	-	65	-	deg	FIG.3	Note6	
	$\theta_B$		-	55	-	deg	FIG.3		
	$\theta_L$		-	65	-	deg	FIG.3		
	$\theta_R$		-	65	-	deg	FIG.3		
Chromaticity	Red	R <sub>X</sub>	$\theta = 0^\circ$ $\phi = 0^\circ$ Ta=25°	TBD	TBD	TBD	-	FIG.2 CIE1931	Note5
		R <sub>Y</sub>		TBD	TBD	TBD	-		
	Green	G <sub>X</sub>		TBD	TBD	TBD	-		
		G <sub>Y</sub>		TBD	TBD	TBD	-		
	Blue	B <sub>X</sub>		TBD	TBD	TBD	-		
		B <sub>Y</sub>		TBD	TBD	TBD	-		
	White	W <sub>X</sub>		TBD	TBD	TBD	-		
		W <sub>Y</sub>		TBD	TBD	TBD	-		

### Note1. Definition of contrast ratio

Contrast ratio(Cr) is defined mathematically by the following formula. For more information see FIG.2.

$$\text{Contrast ratio} = \frac{\text{Luminance measured when LCD on the "White" state}}{\text{Luminance measured when LCD on the "Black" state}}$$

For contrast ratio, Surface Luminance, Luminance uniformity and CIE, the testing data is based on TOPCON's BM-5 or BM-7 photo detector or compatible.

**Note2. Definition of surface luminance.**

Surface luminance is the luminance with all pixels displaying white. For more information see FIG.2.

$L_v$  = Average Surface Luminance with all white pixels(P1,P2,P3, .....Pn)

**Note3. Definition of luminance uniformity**

The luminance uniformity in surface luminance is determined by measuring luminance at each test position 1 through n, and then dividing the maximum luminance of n points luminance by minimum luminance of n points luminance.For more information see FIG.2.

$$YU = \frac{\text{Minimum surface luminance with all white pixels (P1,P2,P3,.....,Pn)}}{\text{Maximum surface luminance with all white pixels (P1,P2,P3,.....,Pn)}}$$

**Note4. Definition of response time**

The response time is defined as the LCD optical switching time interval between “White” state and “Black”state.Rise time ( $T_r$ ) is the time between photo detector output intensity changed from 90% to 10%. And fall time ( $T_f$ ) is the time between photo detector output intensity changed from 10% to 90%.

For additional information see FIG1.

**Note5. Definition of color chromaticity (CIE1931)**

CIE (x,y) chromaticity,The x,y value is determined by screen active area center position P5.For more information see FIG.2.

**Note6. Definition of viewing angle**

Viewing angle is the angle at which the contrast ratio is greater than 10. Angles are determined for the horizontal or x axis and the vertical or y axis with respect to the z axis which is normal to the LCD surface. For more information see FIG.3.

For viewing angle and response time testing, the testing data is base on Autronic-Melchers’ s ConoScope or DMS series Instruments or compatible.

FIG.1.The definition of response Time

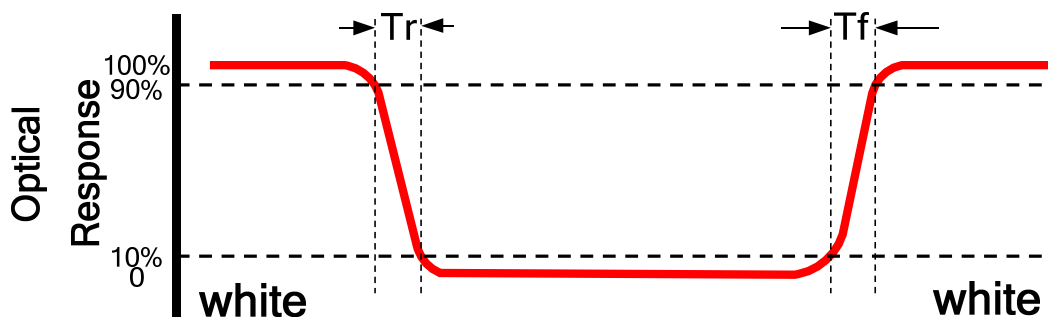

FIG.2. Measuring method for contrast ratio, surface luminance,

**luminance uniformity, CIE (x,y) chromaticity**

Size : S≤5”(see Figure a) A : 5 mm B : 5 mm

H,V : Active area

Light spot size  $\varnothing=5\text{mm}$ (BM-5) or  $\varnothing=7.7\text{mm}$  (BM-7)50cm distance or compatible distance from the LCD surface to detector lens.

test spot position : see Figure a.

measurement instrument : TOPCON’s luminance meter BM-5 or BM-7 or compatible (see Figure c).

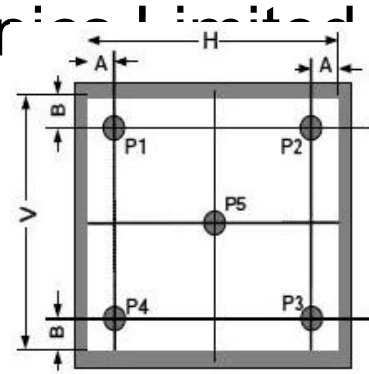

Figure a

Size : 5” < S ≤ 12.3”(see Figure b) H,V : Active area

Light spot size  $\varnothing=5\text{mm}$ (BM-5) or  $\varnothing=7.7\text{mm}$  (BM-7)50cm distance or compatible distance from the LCD surface to detector lens.

test spot position : see Figure b.

measurement instrument : TOPCON’s luminance meter BM-5 or BM-7 or compatible (see Figure c).

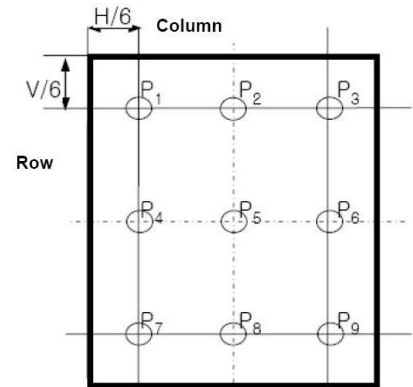

Figure b

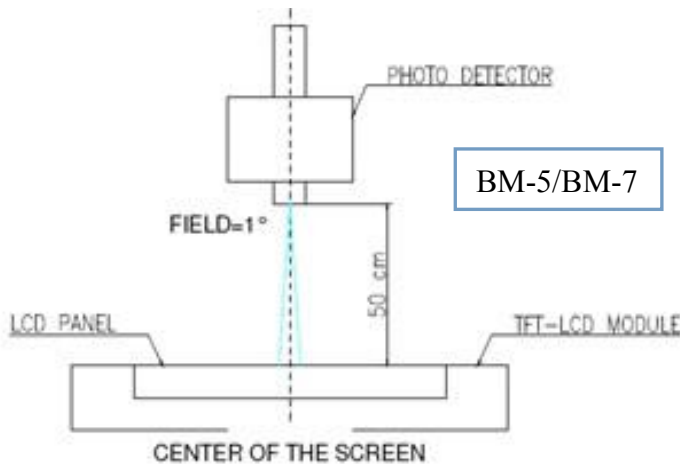
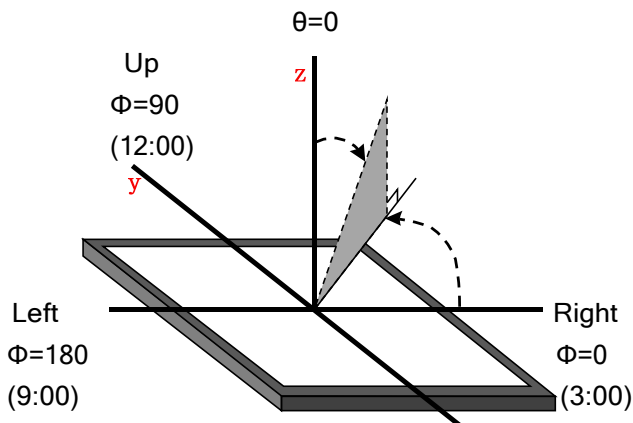

Figure c

FIG.3.The definition of viewing angle



Down  
Φ=270  
(6:00)

## 8.Environmental / Reliability Tests

Test Item	Test Conditions
High Temperature Storage	Ta= +80°C 96hrs
Low Temperature Storage	Ta= -30°C 96hrs
High Temperature Operation	Ta= +70°C 96hrs
Low Temperature Operation	Ta= -20°C 96hrs
High Temperature and Humidity Operation	Ta= +60°C, 90% RH 96hrs
Thermal Shock (Non-operation)	-30°C/30 min ~ +80°C/30 min for 20 cycles Start with cold temperature, end with high temperature
Electro Static Discharge	Contact = ± 4 kV, class B Air = ± 8 kV, class B R=330Ω,C=150pF
Vibration	Sweep: 10Hz~55Hz~10Hz Stroke: 1.5mm 2 hrs for each direction of X .Y. Z.
Mechanical Shock	60G 6ms,±X,±Y,±Z 3 times for each direction
Package Drop Test	Height: 60 cm, 1 corner, 3 edges, 6 surfaces

Notes:

1. The test result shall be evaluated after the sample has been left at room temperature and humidity for 2 hours without load. No condensation shall be accepted. The sample will not be accepted if appear these defects:

- 1).Air bubble in the LCD;
- 2).Seal leak or Glass crack



# CDTech(H.K.)Electronics Limited

- 3).Non display or abnormal display
- 4).Brightness reduction >50%

## 9.Mechanical Drawing

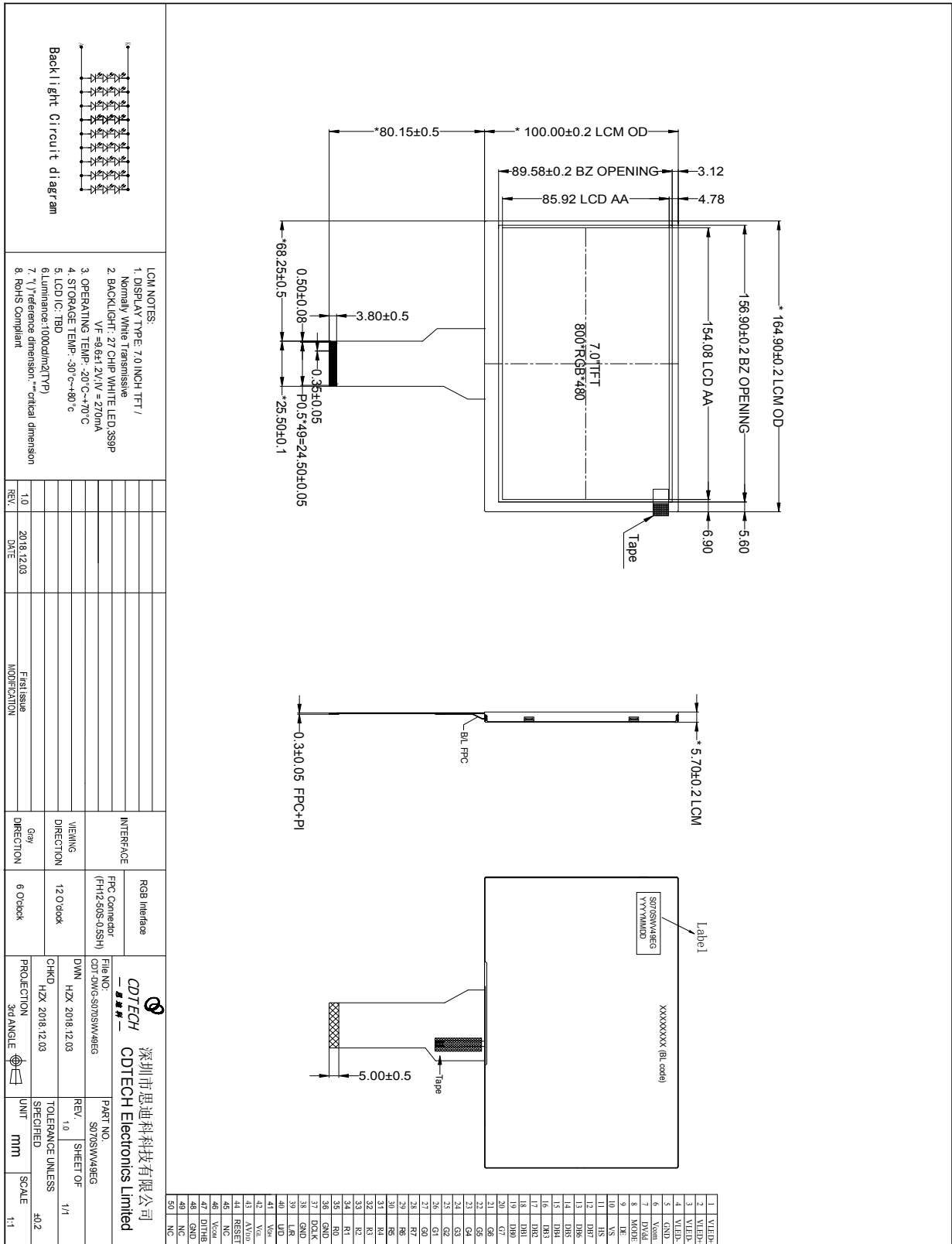





# CDTech(H.K.)Electronics Limited

## 10.Packing

TBD

## 11. Precautions for Use of LCD modules

### 11.1 Handling Precautions

11.1.1. The display panel is made of glass. Do not subject it to a mechanical shock by dropping it from a high place, etc.

11.1.2. If the display panel is damaged and the liquid crystal substance inside it leaks out, be sure not to get any in your mouth, if the substance comes into contact with your skin or clothes, promptly wash it off using soap and water.

11.1.3. Do not apply excessive force to the display surface or the adjoining areas since this may cause the color tone to vary.

11.1.4. The polarizer covering the display surface of the LCD module is soft and easily scratched. Handle this polarizer carefully.

11.1.5. If the display surface is contaminated, breathe on the surface and gently wipe it with a soft dry cloth. If still not completely clear, moisten cloth with one of the following solvents:

- Isopropyl alcohol
- Ethyl alcohol

Solvents other than those mentioned above may damage the polarizer. Especially, do not use the following:

- Water
- Ketene

11.1.6. Do not attempt to disassemble the LCD Module.

11.1.7. If the logic circuit power is off, do not apply the input signals.

11.1.8. To prevent destruction of the elements by static electricity, be careful to maintain an optimum work environment.

11.1.8.1. Be sure to ground the body when handling the LCD Modules.

11.1.8.2. Tools required for assembly, such as soldering irons, must be properly ground.

11.1.8.3. To reduce the amount of static electricity generated, do not conduct assembly and other work under dry conditions.

11.1.8.4. The LCD Module is coated with a film to protect the display surface. Be care when peeling off this protective film since static electricity may be generated.

### 11.2 Storage Precautions

11.2.1. When storing the LCD modules, avoid exposure to direct sunlight or to the light of fluorescent lamps.

11.2.2. The LCD modules should be stored under the storage temperature range. If the LCD modules will be stored for a long time, the recommend condition is:

Temperature : 0°C ~ 40°C      Relatively humidity: ≤80%

11.2.3. The LCD modules should be stored in the room without acid, alkali and harmful gas.

### 11.3 Transportation Precautions

The LCD modules should be no falling and violent shocking during transportation, and also should avoid excessive press, water, damp and sunshine.