



# ST7272A

---

**480x480 System-On-Chip Driver  
for 320RGBx240 Dual Gate TFT LCD**

---

## Datasheet

Sitronix reserves the right to change the contents in this document without prior notice, please contact Sitronix to obtain the latest version of datasheet before placing your order. No responsibility is assumed by Sitronix for any infringement of patent or other rights of third parties which may result from its use.

© 2018 Sitronix Technology Corporation. All rights reserved.

**Version 0.4**  
**2018/03**

**Sitronix Technology Corporation**

Sitronix Technology Corp. reserves the right to change the contents in this document without prior notice.

**LIST OF CONTENT**

**1. GENERAL DESCRIPTION ..... 5**

**2. FEATURES ..... 6**

**3. PAD ARRANGEMENT ..... 7**

    3.1 Output Bump Dimension .....7

    3.2 Bump Dimension.....8

    3.3 Alignment Mark Dimension .....9

**4. PAD CENTER COORDINATES ..... 10**

**5. BLOCK DIAGRAM ..... 33**

**6. PIN DESCRIPTION ..... 34**

    6.1 Pin Function .....34

**7. COMMUNICATION INTERFACE ..... 37**

    7.1 3-wire Serial Interface .....37

    7.2 I<sup>2</sup>C Interface .....38

        7.2.1 Bit Transfer..... 38

        7.2.2 START and STOP Conditions..... 38

        7.2.3 System Configuration ..... 39

        7.2.4 Acknowledgment ..... 39

        7.2.5 I<sup>2</sup>C Interface Protocol ..... 40

    7.3 RGB Interface .....41

        7.3.1 SYNC Mode ..... 41

        7.3.2 SYNC-DE Mode ..... 42

        7.3.3 DE Mode ..... 43

        7.3.4 Parallel 24-bit RGB Input Timing Table ..... 44

        7.3.5 Serial 8-bit RGB Input Timing Table ..... 45

**8. REGISTER LIST..... 46**

    8.1 Register Summary .....46

    8.2 Command Table1 Register Description .....49

        8.2.1 GRB、DISP CONTROL (10h) ..... 49

        8.2.2 CONTRAST (11h) ..... 49

        8.2.3 SUB\_CONTRAST\_R (12h) ..... 49

        8.2.4 SUB\_CONTRAST\_B (13h) ..... 50

        8.2.5 BRIGHTNESS (14h) ..... 50

        8.2.6 SUB-BRIGHTNESS\_R (15h) ..... 50

        8.2.7 SUB-BRIGHTNESS\_B (16h) ..... 51

        8.2.8 H\_BLANKING (17h) ..... 51

        8.2.9 V\_BLANKING (18h) ..... 51

        8.2.10 DISPLAY MODE SETTING (19h) ..... 52

8.2.11 RGB INTERFACE MODE SETTING (1Ah).....	53
8.2.12 ERROR REPORT AND OTP AUTO DOWNLOAD CONTROL (1Bh) .....	54
8.2.13 BIST FUNCTION SETTING (1Ch).....	54
<b>8.3 Command Table2 Register Description .....</b>	<b>55</b>
8.3.1 GVDD SETTING (40h).....	55
8.3.2 GVCL SETTING (41h) .....	56
8.3.3 VCOM SETTING (43h) .....	57
8.3.4 AVDD, AVCL SETTING (44h).....	58
8.3.5 VGH, VGL SETTING (45h) .....	59
8.3.6 SOURCE EQUALIZE TIME SETTING (46h) .....	60
8.3.7 SOURCE OP-AMP POWER SETTING (47h).....	61
8.3.8 GATE TIMING SETTING 1 (49h).....	62
8.3.9 GATE TIMING SETTING 2 (4Ah) .....	63
<b>8.4 Gamma Table Register Description .....</b>	<b>64</b>
8.4.1 GAMMA SETTING (20h~29h, 30h~39h) .....	64
<b>8.5 OTP Table Register Description .....</b>	<b>66</b>
8.5.1 ID1 SETTING (01h).....	66
8.5.2 ID2 SETTING (02h).....	66
8.5.3 ID3 SETTING (03h).....	66
8.5.4 2C ID CODE SETTING (04h).....	66
8.5.5 VCOM OFFSET SETTING (05h) .....	67
8.5.6 OTP FUNCTION CONTROL (60h) .....	67
8.5.7 OTP ACKNOWLEDGEMENT CONTROL (65h) .....	68
8.5.8 VCOM OFFSET OTP PROGRAM TIMES (66h).....	68
8.5.9 COMMAND 2 PROGRAM TIMES (67h) .....	68
8.5.10 GAMMA OTP PROGRAM TIMES (68h) .....	68
8.5.11 ID1 OTP PROGRAM TIMES (69h) .....	69
8.5.12 ID2 OTP PROGRAM TIMES (6Ah).....	69
8.5.13 ID3 OTP PROGRAM TIMES (6Bh).....	69
8.5.14 I <sup>2</sup> C ID OTP PROGRAM TIMES (6Ch).....	69
<b>9. ELECTRICAL SPECIFICATIONS .....</b>	<b>70</b>
9.1 Absolute Maximum Ratings .....	70
9.2 DC Characteristics .....	71
9.2.1 Recommended Operating Range .....	71
9.2.2 DC Characteristics for Digital Circuit.....	71
9.2.3 DC Characteristics for Analog Circuit .....	71
9.3 AC Characteristics .....	72
9.3.1 System Operation AC Characteristics .....	72
9.3.2 System Bus Timing for I <sup>2</sup> C Interface .....	72

---

9.3.3 System Bus Timing for 3-Wire SPI Interface .....	73
9.3.4 System Bus Timing for RGB Interface .....	74
<b>10. APPLICATION CIRCUIT .....</b>	<b>75</b>
10.1 External Component of Power Circuit .....	75
10.2 Parallel 24-bit RGB with 3-wire SPI .....	76
10.3 Serial 8-bit RGB with 3-wire SPI .....	77
10.4 OTP Operation.....	78
<b>11. POWER ON/OFF SEQUENCE.....</b>	<b>79</b>
11.1 Power On Sequence.....	79
11.2 Power Off Sequence.....	79
<b>12. BIST FUNCTION .....</b>	<b>80</b>
12.1 BIST Pattern .....	80
<b>13. OTP PROGRAM FLOW .....</b>	<b>81</b>
13.1 VCOM Offset OTP Flow.....	81
13.2 Custom Application ID Code OTP Flow .....	83
<b>14. RECOMMENDED PANEL ROUTING RESISTANCE .....</b>	<b>85</b>
<b>15. COLOR FILTER ARRANGEMENT .....</b>	<b>86</b>
<b>16. SOURCE VOLTAGE RELATIONS.....</b>	<b>87</b>
<b>17. REVISION HISTORY.....</b>	<b>88</b>

## 1. GENERAL DESCRIPTION

ST7272A offers all-in-one chip solution of 320RGBx240 for dual gate color TFT-LCD panel. The driver IC output ports consists of 480 source channels and 480 gate channels. This chip incorporated with digital timing generator, source and gate driver, power supply circuit and embedded serial communication interface for function setting. This chip can support parallel 24-bit RGB and serial 8-bit RGB interface. The source output support real 8-bit resolution and 256-gray scale with small output deviation are designed to support higher color resolution. The power supply circuit incorporated with step-up circuit, regulators and operational amplifiers to generate power supply voltages to drive TFT LCD.

SITRONIX CONFIDENTIAL

## 2. FEATURES

- Display Maximum Resolution:
  - support dual gate panel resolution: 320RGB \* 240
- LCD Driver Output Circuits
  - source outputs: 480 channels
  - gate outputs: 480 channels
  - common electrode output
- 256 Gray Scale with True 8-bit DAC
- Microprocessor Interface
  - 8-bit and 24-bit RGB interface support: SYNC, SYNC-DE and DE mode
  - 3-wire SPI and I<sup>2</sup>C interface
- On Chip Build-In Circuits
  - DC/DC converter
  - multi-OTP circuit (3 times)
  - timing controller
- Wide Supply Voltage Range
  - I/O voltage (VDDI to DGND): 3.0V ~ 3.6V
  - analog voltage (VDD to AGND): 3.0V ~ 3.6V
  - charge pump voltage (PVDD to PGND): 3.0V ~ 3.6V
- On-Chip Power System
  - GVDD: 4.960V ~ 5.968V
  - GVCL: -2.960V ~ -4.480V
  - VGSP: 0.272V ~ 1.504V ( $VGSP = (GVDD + GVCL) / 2$ , the VGSP voltage is set by panel characteristics)
  - VCOM: -0.208V ~ -1.216V (the VCOM voltage is set by panel characteristics)
  - gate high level (VGH to AGND): 13V ~ 16.5V
  - gate low level (VGL to AGND): -7V ~ -11V
- Optimized Layout for COG Assembly
- Built-in Multi-OTP Programming Circuit
  - internal VPP power supply
- Multi-OTP Adjustable Parameters
  - 7-bit for VCOM offset adjustment
  - 7-bit ID1/ ID2/ ID3 for end user use

### 3. PAD ARRANGEMENT

#### 3.1 Output Bump Dimension

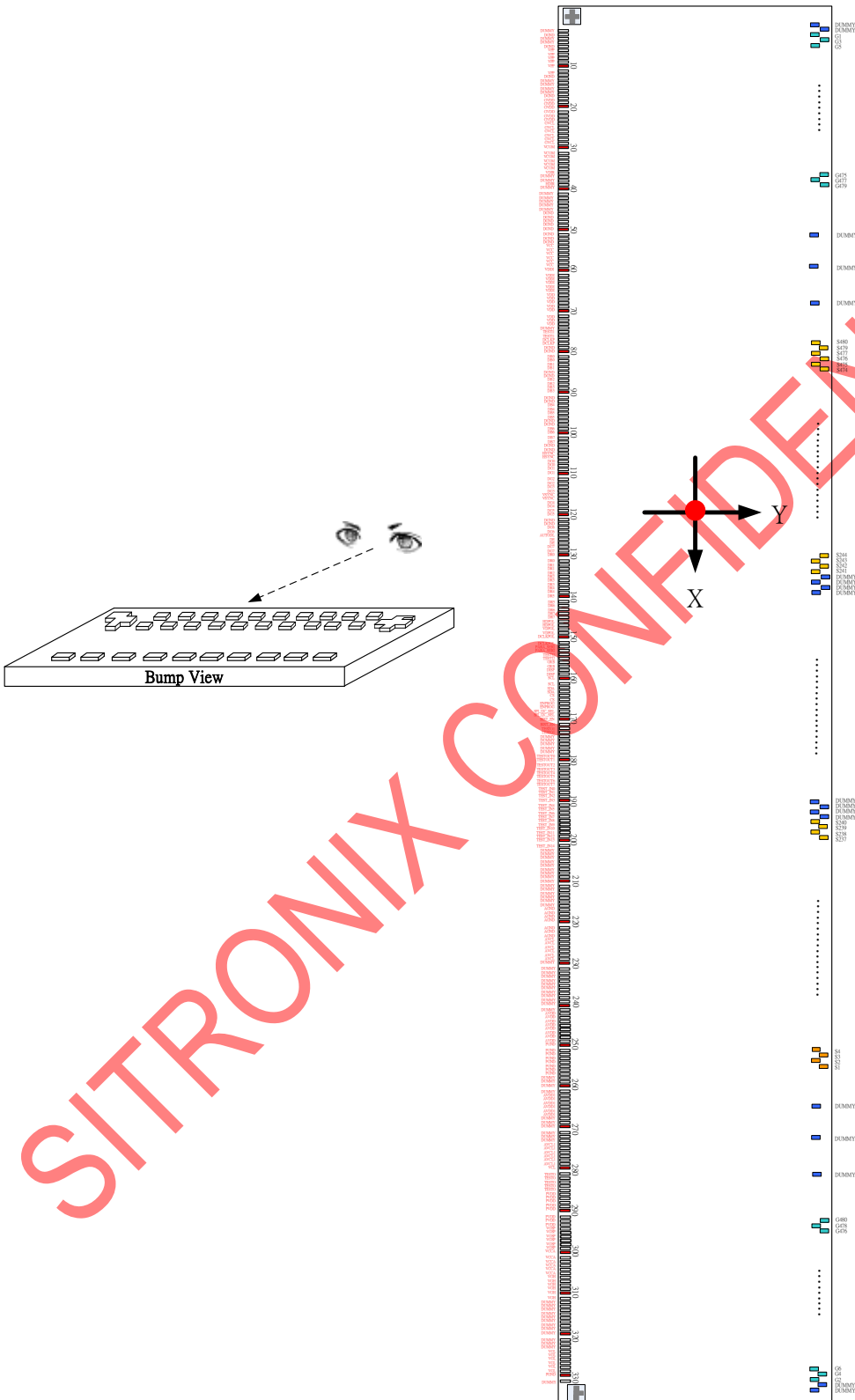

### 3.2 Bump Dimension

Output Pads

S1~S480、G1~G480、VCOM、DUMMY

(No.332~1548)

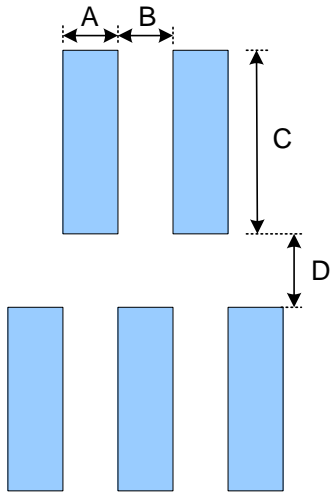

Symbol	Item	Size
A	Bump Width	15 $\mu$ m
B	Bump Gap 1 (Horizontal)	15、30、75 $\mu$ m
C	Bump Height	100 $\mu$ m
D	Bump Gap 2 (Vertical)	30 $\mu$ m

Input Pads

(No.1~331)

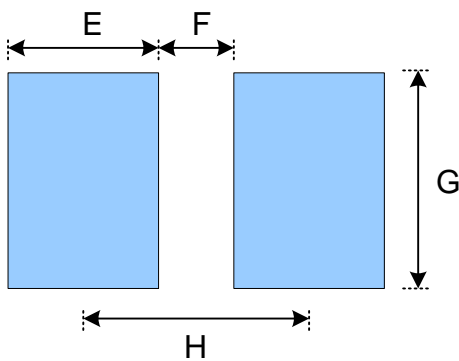

Symbol	Item	Size
E	Bump Width	35 $\mu$ m
F	Bump Gap	24 $\mu$ m
G	Bump Height	100 $\mu$ m
H	Bump Pitch	59 $\mu$ m



3.3 Alignment Mark Dimension

Alignment Mark: A1(X,Y)=(-9963,-235)

Alignment Mark: A2(X,Y)=(9963,-235)

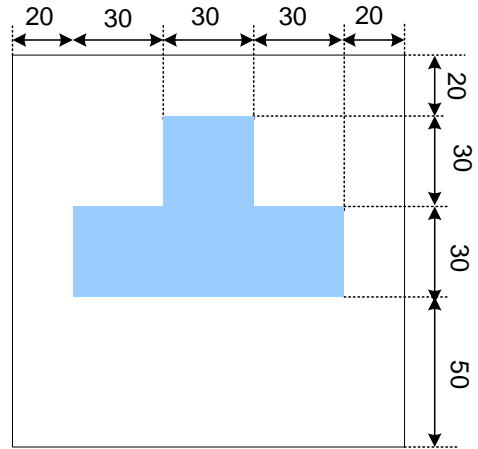
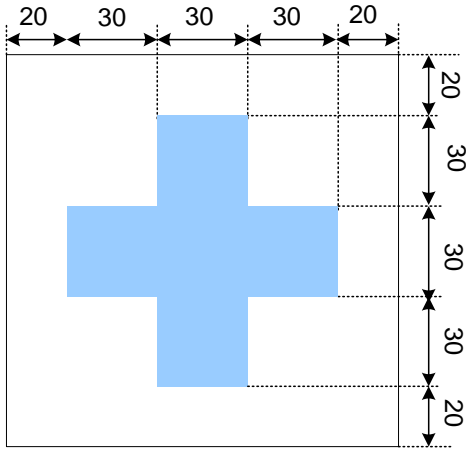

SITRONIX CONFIDENTIAL

4. PAD CENTER COORDINATES

PAD No.	PIN Name	X	Y	PAD No.	PIN Name	X	Y
1	DUMMY	-9735	-257	34	VCOM	-7788	-257
2	DGND	-9676	-257	35	VCOM	-7729	-257
3	DUMMY	-9617	-257	36	VDIR	-7670	-257
4	DUMMY	-9558	-257	37	DUMMY	-7611	-257
5	DGND	-9499	-257	38	DUMMY	-7552	-257
6	VPP	-9440	-257	39	HDIR	-7493	-257
7	VPP	-9381	-257	40	DUMMY	-7434	-257
8	VPP	-9322	-257	41	DUMMY	-7375	-257
9	VPP	-9263	-257	42	DUMMY	-7316	-257
10	VPP	-9204	-257	43	DUMMY	-7257	-257
11	VPP	-9145	-257	44	DUMMY	-7198	-257
12	DGND	-9086	-257	45	DUMMY	-7139	-257
13	DUMMY	-9027	-257	46	DGND	-7080	-257
14	DUMMY	-8968	-257	47	DGND	-7021	-257
15	DUMMY	-8909	-257	48	DGND	-6962	-257
16	DUMMY	-8850	-257	49	DGND	-6903	-257
17	DGND	-8791	-257	50	DGND	-6844	-257
18	GVDD	-8732	-257	51	DGND	-6785	-257
19	GVDD	-8673	-257	52	DGND	-6726	-257
20	GVDD	-8614	-257	53	DGND	-6667	-257
21	GVDD	-8555	-257	54	VCC	-6608	-257
22	GVDD	-8496	-257	55	VCC	-6549	-257
23	GVDD	-8437	-257	56	VCC	-6490	-257
24	GVCL	-8378	-257	57	VCC	-6431	-257
25	GVCL	-8319	-257	58	VCC	-6372	-257
26	GVCL	-8260	-257	59	VCC	-6313	-257
27	GVCL	-8201	-257	60	VDDI	-6254	-257
28	GVCL	-8142	-257	61	VDDI	-6195	-257
29	GVCL	-8083	-257	62	VDDI	-6136	-257
30	VCOM	-8024	-257	63	VDDI	-6077	-257
31	VCOM	-7965	-257	64	VDDI	-6018	-257
32	VCOM	-7906	-257	65	VDDI	-5959	-257
33	VCOM	-7847	-257	66	VDD	-5900	-257

PAD No.	PIN Name	X	Y	PAD No.	PIN Name	X	Y
67	VDD	-5841	-257	101	DB7	-3835	-257
68	VDD	-5782	-257	102	DB7	-3776	-257
69	VDD	-5723	-257	103	DGND	-3717	-257
70	VDD	-5664	-257	104	DGND	-3658	-257
71	VDD	-5605	-257	105	HSYNC	-3599	-257
72	VDD	-5546	-257	106	HSYNC	-3540	-257
73	VDD	-5487	-257	107	DG0	-3481	-257
74	DUMMY	-5428	-257	108	DG0	-3422	-257
75	TESETI1	-5369	-257	109	DG1	-3363	-257
76	TESETI1	-5310	-257	110	DG1	-3304	-257
77	DCLKP	-5251	-257	111	DG2	-3245	-257
78	DCLKP	-5192	-257	112	DG2	-3186	-257
79	DGND	-5133	-257	113	DG3	-3127	-257
80	DGND	-5074	-257	114	DG3	-3068	-257
81	DB0	-5015	-257	115	VSYNC	-3009	-257
82	DB0	-4956	-257	116	VSYNC	-2950	-257
83	DB1	-4897	-257	117	DG4	-2891	-257
84	DB1	-4838	-257	118	DG4	-2832	-257
85	DGND	-4779	-257	119	DG5	-2773	-257
86	DGND	-4720	-257	120	DG5	-2714	-257
87	DB2	-4661	-257	121	DGND	-2655	-257
88	DB2	-4602	-257	122	DGND	-2596	-257
89	DB3	-4543	-257	123	DG6	-2537	-257
90	DB3	-4484	-257	124	DG6	-2478	-257
91	DGND	-4425	-257	125	AUTODL	-2419	-257
92	DGND	-4366	-257	126	DE	-2360	-257
93	DB4	-4307	-257	127	DE	-2301	-257
94	DB4	-4248	-257	128	DG7	-2242	-257
95	DB5	-4189	-257	129	DG7	-2183	-257
96	DB5	-4130	-257	130	DR0	-2124	-257
97	DGND	-4071	-257	131	DR0	-2065	-257
98	DGND	-4012	-257	132	DR1	-2006	-257
99	DB6	-3953	-257	133	DR1	-1947	-257
100	DB6	-3894	-257	134	DR2	-1888	-257

PAD No.	PIN Name	X	Y
135	DR2	-1829	-257
136	DR3	-1770	-257
137	DR3	-1711	-257
138	DR4	-1652	-257
139	DR4	-1593	-257
140	DR5	-1534	-257
141	DR5	-1475	-257
142	DR6	-1416	-257
143	DR6	-1357	-257
144	DR7	-1298	-257
145	DR7	-1239	-257
146	HDPOL	-1180	-257
147	HDPOL	-1121	-257
148	VDPOL	-1062	-257
149	VDPOL	-1003	-257
150	DCLKPOL	-944	-257
151	DCLKPOL	-885	-257
152	PARA_SERI	-826	-257
153	PARA_SERI	-767	-257
154	TESTI2	-708	-257
155	TESTI2	-649	-257
156	GRB	-590	-257
157	GRB	-531	-257
158	DISP	-472	-257
159	DISP	-413	-257
160	SCL	-354	-257
161	SCL	-295	-257
162	SDA	-236	-257
163	SDA	-177	-257
164	CS	-118	-257
165	CS	-59	-257
166	ENPROG	0	-257
167	ENPROG	59	-257
168	SPI_I <sup>2</sup> C_SEL	118	-257

PAD No.	PIN Name	X	Y
169	SPI_I <sup>2</sup> C_SEL	177	-257
170	BIST_EN	236	-257
171	BIST_EN	295	-257
172	TESTO1	354	-257
173	TESTO1	413	-257
174	DUMMY	472	-257
175	DUMMY	531	-257
176	DUMMY	590	-257
177	DUMMY	649	-257
178	DUMMY	708	-257
179	TESTOUT0	767	-257
180	TESTOUT1	826	-257
181	TESTOUT2	885	-257
182	TESTOUT3	944	-257
183	TESTOUT4	1003	-257
184	TESTOUT5	1062	-257
185	TESTOUT6	1121	-257
186	TESTOUT7	1180	-257
187	TEST_IN0	1239	-257
188	TEST_IN1	1298	-257
189	TEST_IN2	1357	-257
190	TEST_IN3	1416	-257
191	TEST_IN4	1475	-257
192	TEST_IN5	1534	-257
193	TEST_IN6	1593	-257
194	TEST_IN7	1652	-257
195	TEST_IN8	1711	-257
196	TESTI_N9	1770	-257
197	TEST_IN10	1829	-257
198	TEST_IN11	1888	-257
199	TEST_IN12	1947	-257
200	TEST_IN13	2006	-257
201	TEST_IN14	2065	-257
202	DUMMY	2124	-257

PAD No.	PIN Name	X	Y	PAD No.	PIN Name	X	Y
203	DUMMY	2183	-257	237	DUMMY	4189	-257
204	DUMMY	2242	-257	238	DUMMY	4248	-257
205	DUMMY	2301	-257	239	DUMMY	4307	-257
206	DUMMY	2360	-257	240	DUMMY	4366	-257
207	DUMMY	2419	-257	241	DUMMY	4425	-257
208	DUMMY	2478	-257	242	AVDD	4484	-257
209	DUMMY	2537	-257	243	AVDD	4543	-257
210	DUMMY	2596	-257	244	AVDD	4602	-257
211	DUMMY	2655	-257	245	AVDD	4661	-257
212	DUMMY	2714	-257	246	AVDD	4720	-257
213	DUMMY	2773	-257	247	AVDD	4779	-257
214	DUMMY	2832	-257	248	AVDD	4838	-257
215	DUMMY	2891	-257	249	AVDD	4897	-257
216	DUMMY	2950	-257	250	PGND	4956	-257
217	AGND	3009	-257	251	PGND	5015	-257
218	AGND	3068	-257	252	PGND	5074	-257
219	AGND	3127	-257	253	PGND	5133	-257
220	AGND	3186	-257	254	PGND	5192	-257
221	AGND	3245	-257	255	PGND	5251	-257
222	AGND	3304	-257	256	PGND	5310	-257
223	AGND	3363	-257	257	PGND	5369	-257
224	AVCL	3422	-257	258	DUMMY	5428	-257
225	AVCL	3481	-257	259	DUMMY	5487	-257
226	AVCL	3540	-257	260	DUMMY	5546	-257
227	AVCL	3599	-257	261	DUMMY	5605	-257
228	AVCL	3658	-257	262	AVDD1	5664	-257
229	AVCL	3717	-257	263	AVDD1	5723	-257
230	DUMMY	3776	-257	264	AVDD1	5782	-257
231	DUMMY	3835	-257	265	AVDD1	5841	-257
232	DUMMY	3894	-257	266	AVDD1	5900	-257
233	DUMMY	3953	-257	267	AVDD1	5959	-257
234	DUMMY	4012	-257	268	DUMMY	6018	-257
235	DUMMY	4071	-257	269	DUMMY	6077	-257
236	DUMMY	4130	-257	270	DUMMY	6136	-257

PAD No.	PIN Name	X	Y	PAD No.	PIN Name	X	Y
271	DUMMY	6195	-257	305	VCCA	8201	-257
272	DUMMY	6254	-257	306	VGH	8260	-257
273	DUMMY	6313	-257	307	VGH	8319	-257
274	AVCL1	6372	-257	308	VGH	8378	-257
275	AVCL1	6431	-257	309	VGH	8437	-257
276	AVCL1	6490	-257	310	VGH	8496	-257
277	AVCL1	6549	-257	311	VGH	8555	-257
278	AVCL1	6608	-257	312	DUMMY	8614	-257
279	AVCL1	6667	-257	313	DUMMY	8673	-257
280	TESTO	6726	-257	314	DUMMY	8732	-257
281	TESTO	6785	-257	315	DUMMY	8791	-257
282	TESTO	6844	-257	316	DUMMY	8850	-257
283	TESTO	6903	-257	317	DUMMY	8909	-257
284	TESTO	6962	-257	318	DUMMY	8968	-257
285	TESTO	7021	-257	319	DUMMY	9027	-257
286	PVDD	7080	-257	320	DUMMY	9086	-257
287	PVDD	7139	-257	321	DUMMY	9145	-257
288	PVDD	7198	-257	322	DUMMY	9204	-257
289	PVDD	7257	-257	323	DUMMY	9263	-257
290	PVDD	7316	-257	324	VGL	9322	-257
291	PVDD	7375	-257	325	VGL	9381	-257
292	PVDD	7434	-257	326	VGL	9440	-257
293	PVDD	7493	-257	327	VGL	9499	-257
294	VGSP	7552	-257	328	VGL	9558	-257
295	VGSP	7611	-257	329	VGL	9617	-257
296	VGSP	7670	-257	330	PGND	9676	-257
297	VGSP	7729	-257	331	DUMMY	9735	-257
298	VGSP	7788	-257	332	DUMMY	9945	127
299	VGSP	7847	-257	333	DUMMY	9930	257
300	VCCA	7906	-257	334	G2	9900	127
301	VCCA	7965	-257	335	G4	9885	257
302	VCCA	8024	-257	336	G6	9870	127
303	VCCA	8083	-257	337	G8	9855	257
304	VCCA	8142	-257	338	G10	9840	127

PAD No.	PIN Name	X	Y
339	G12	9825	257
340	G14	9810	127
341	G16	9795	257
342	G18	9780	127
343	G20	9765	257
344	G22	9750	127
345	G24	9735	257
346	G26	9720	127
347	G28	9705	257
348	G30	9690	127
349	G32	9675	257
350	G34	9660	127
351	G36	9645	257
352	G38	9630	127
353	G40	9615	257
354	G42	9600	127
355	G44	9585	257
356	G46	9570	127
357	G48	9555	257
358	G50	9540	127
359	G52	9525	257
360	G54	9510	127
361	G56	9495	257
362	G58	9480	127
363	G60	9465	257
364	G62	9450	127
365	G64	9435	257
366	G66	9420	127
367	G68	9405	257
368	G70	9390	127
369	G72	9375	257
370	G74	9360	127
371	G76	9345	257
372	G78	9330	127

PAD No.	PIN Name	X	Y
373	G80	9315	257
374	G82	9300	127
375	G84	9285	257
376	G86	9270	127
377	G88	9255	257
378	G90	9240	127
379	G92	9225	257
380	G94	9210	127
381	G96	9195	257
382	G98	9180	127
383	G100	9165	257
384	G102	9150	127
385	G104	9135	257
386	G106	9120	127
387	G108	9105	257
388	G110	9090	127
389	G112	9075	257
390	G114	9060	127
391	G116	9045	257
392	G118	9030	127
393	G120	9015	257
394	G122	9000	127
395	G124	8985	257
396	G126	8970	127
397	G128	8955	257
398	G130	8940	127
399	G132	8925	257
400	G134	8910	127
401	G136	8895	257
402	G138	8880	127
403	G140	8865	257
404	G142	8850	127
405	G144	8835	257
406	G146	8820	127

PAD No.	PIN Name	X	Y	PAD No.	PIN Name	X	Y
407	G148	8805	257	441	G216	8295	257
408	G150	8790	127	442	G218	8280	127
409	G152	8775	257	443	G220	8265	257
410	G154	8760	127	444	G222	8250	127
411	G156	8745	257	445	G224	8235	257
412	G158	8730	127	446	G226	8220	127
413	G160	8715	257	447	G228	8205	257
414	G162	8700	127	448	G230	8190	127
415	G164	8685	257	449	G232	8175	257
416	G166	8670	127	450	G234	8160	127
417	G168	8655	257	451	G236	8145	257
418	G170	8640	127	452	G238	8130	127
419	G172	8625	257	453	G240	8115	257
420	G174	8610	127	454	G242	8100	127
421	G176	8595	257	455	G244	8085	257
422	G178	8580	127	456	G246	8070	127
423	G180	8565	257	457	G248	8055	257
424	G182	8550	127	458	G250	8040	127
425	G184	8535	257	459	G252	8025	257
426	G186	8520	127	460	G254	8010	127
427	G188	8505	257	461	G256	7995	257
428	G190	8490	127	462	G258	7980	127
429	G192	8475	257	463	G260	7965	257
430	G194	8460	127	464	G262	7950	127
431	G196	8445	257	465	G264	7935	257
432	G198	8430	127	466	G266	7920	127
433	G200	8415	257	467	G268	7905	257
434	G202	8400	127	468	G270	7890	127
435	G204	8385	257	469	G272	7875	257
436	G206	8370	127	470	G274	7860	127
437	G208	8355	257	471	G276	7845	257
438	G210	8340	127	472	G278	7830	127
439	G212	8325	257	473	G280	7815	257
440	G214	8310	127	474	G282	7800	127



PAD No.	PIN Name	X	Y
475	G284	7785	257
476	G286	7770	127
477	G288	7755	257
478	G290	7740	127
479	G292	7725	257
480	G294	7710	127
481	G296	7695	257
482	G298	7680	127
483	G300	7665	257
484	G302	7650	127
485	G304	7635	257
486	G306	7620	127
487	G308	7605	257
488	G310	7590	127
489	G312	7575	257
490	G314	7560	127
491	G316	7545	257
492	G318	7530	127
493	G320	7515	257
494	G322	7500	127
495	G324	7485	257
496	G326	7470	127
497	G328	7455	257
498	G330	7440	127
499	G332	7425	257
500	G334	7410	127
501	G336	7395	257
502	G338	7380	127
503	G340	7365	257
504	G342	7350	127
505	G344	7335	257
506	G346	7320	127
507	G348	7305	257
508	G350	7290	127

PAD No.	PIN Name	X	Y
509	G352	7275	257
510	G354	7260	127
511	G356	7245	257
512	G358	7230	127
513	G360	7215	257
514	G362	7200	127
515	G364	7185	257
516	G366	7170	127
517	G368	7155	257
518	G370	7140	127
519	G372	7125	257
520	G374	7110	127
521	G376	7095	257
522	G378	7080	127
523	G380	7065	257
524	G382	7050	127
525	G384	7035	257
526	G386	7020	127
527	G388	7005	257
528	G390	6990	127
529	G392	6975	257
530	G394	6960	127
531	G396	6945	257
532	G398	6930	127
533	G400	6915	257
534	G402	6900	127
535	G404	6885	257
536	G406	6870	127
537	G408	6855	257
538	G410	6840	127
539	G412	6825	257
540	G414	6810	127
541	G416	6795	257
542	G418	6780	127

PAD No.	PIN Name	X	Y	PAD No.	PIN Name	X	Y
543	G420	6765	257	577	S1	5610	127
544	G422	6750	127	578	S2	5595	257
545	G424	6735	257	579	S3	5580	127
546	G426	6720	127	580	S4	5565	257
547	G428	6705	257	581	S5	5550	127
548	G430	6690	127	582	S6	5535	257
549	G432	6675	257	583	S7	5520	127
550	G434	6660	127	584	S8	5505	257
551	G436	6645	257	585	S9	5490	127
552	G438	6630	127	586	S10	5475	257
553	G440	6615	257	587	S11	5460	127
554	G442	6600	127	588	S12	5445	257
555	G444	6585	257	589	S13	5430	127
556	G446	6570	127	590	S14	5415	257
557	G448	6555	257	591	S15	5400	127
558	G450	6540	127	592	S16	5385	257
559	G452	6525	257	593	S17	5370	127
560	G454	6510	127	594	S18	5355	257
561	G456	6495	257	595	S19	5340	127
562	G458	6480	127	596	S20	5325	257
563	G460	6465	257	597	S21	5310	127
564	G462	6450	127	598	S22	5295	257
565	G464	6435	257	599	S23	5280	127
566	G466	6420	127	600	S24	5265	257
567	G468	6405	257	601	S25	5250	127
568	G470	6390	127	602	S26	5235	257
569	G472	6375	257	603	S27	5220	127
570	G474	6360	127	604	S28	5205	257
571	G476	6345	257	605	S29	5190	127
572	G478	6330	127	606	S30	5175	257
573	G480	6315	257	607	S31	5160	127
574	DUMMY	6150	127	608	S32	5145	257
575	DUMMY	5970	127	609	S33	5130	127
576	DUMMY	5760	127	610	S34	5115	257

PAD No.	PIN Name	X	Y
611	S35	5100	127
612	S36	5085	257
613	S37	5070	127
614	S38	5055	257
615	S39	5040	127
616	S40	5025	257
617	S41	5010	127
618	S42	4995	257
619	S43	4980	127
620	S44	4965	257
621	S45	4950	127
622	S46	4935	257
623	S47	4920	127
624	S48	4905	257
625	S49	4890	127
626	S50	4875	257
627	S51	4860	127
628	S52	4845	257
629	S53	4830	127
630	S54	4815	257
631	S55	4800	127
632	S56	4785	257
633	S57	4770	127
634	S58	4755	257
635	S59	4740	127
636	S60	4725	257
637	S61	4710	127
638	S62	4695	257
639	S63	4680	127
640	S64	4665	257
641	S65	4650	127
642	S66	4635	257
643	S67	4620	127
644	S68	4605	257

PAD No.	PIN Name	X	Y
645	S69	4590	127
646	S70	4575	257
647	S71	4560	127
648	S72	4545	257
649	S73	4530	127
650	S74	4515	257
651	S75	4500	127
652	S76	4485	257
653	S77	4470	127
654	S78	4455	257
655	S79	4440	127
656	S80	4425	257
657	S81	4410	127
658	S82	4395	257
659	S83	4380	127
660	S84	4365	257
661	S85	4350	127
662	S86	4335	257
663	S87	4320	127
664	S88	4305	257
665	S89	4290	127
666	S90	4275	257
667	S91	4260	127
668	S92	4245	257
669	S93	4230	127
670	S94	4215	257
671	S95	4200	127
672	S96	4185	257
673	S97	4170	127
674	S98	4155	257
675	S99	4140	127
676	S100	4125	257
677	S101	4110	127
678	S102	4095	257

PAD No.	PIN Name	X	Y	PAD No.	PIN Name	X	Y
679	S103	4080	127	713	S137	3570	127
680	S104	4065	257	714	S138	3555	257
681	S105	4050	127	715	S139	3540	127
682	S106	4035	257	716	S140	3525	257
683	S107	4020	127	717	S141	3510	127
684	S108	4005	257	718	S142	3495	257
685	S109	3990	127	719	S143	3480	127
686	S110	3975	257	720	S144	3465	257
687	S111	3960	127	721	S145	3450	127
688	S112	3945	257	722	S146	3435	257
689	S113	3930	127	723	S147	3420	127
690	S114	3915	257	724	S148	3405	257
691	S115	3900	127	725	S149	3390	127
692	S116	3885	257	726	S150	3375	257
693	S117	3870	127	727	S151	3360	127
694	S118	3855	257	728	S152	3345	257
695	S119	3840	127	729	S153	3330	127
696	S120	3825	257	730	S154	3315	257
697	S121	3810	127	731	S155	3300	127
698	S122	3795	257	732	S156	3285	257
699	S123	3780	127	733	S157	3270	127
700	S124	3765	257	734	S158	3255	257
701	S125	3750	127	735	S159	3240	127
702	S126	3735	257	736	S160	3225	257
703	S127	3720	127	737	S161	3210	127
704	S128	3705	257	738	S162	3195	257
705	S129	3690	127	739	S163	3180	127
706	S130	3675	257	740	S164	3165	257
707	S131	3660	127	741	S165	3150	127
708	S132	3645	257	742	S166	3135	257
709	S133	3630	127	743	S167	3120	127
710	S134	3615	257	744	S168	3105	257
711	S135	3600	127	745	S169	3090	127
712	S136	3585	257	746	S170	3075	257

PAD No.	PIN Name	X	Y
747	S171	3060	127
748	S172	3045	257
749	S173	3030	127
750	S174	3015	257
751	S175	3000	127
752	S176	2985	257
753	S177	2970	127
754	S178	2955	257
755	S179	2940	127
756	S180	2925	257
757	S181	2910	127
758	S182	2895	257
759	S183	2880	127
760	S184	2865	257
761	S185	2850	127
762	S186	2835	257
763	S187	2820	127
764	S188	2805	257
765	S189	2790	127
766	S190	2775	257
767	S191	2760	127
768	S192	2745	257
769	S193	2730	127
770	S194	2715	257
771	S195	2700	127
772	S196	2685	257
773	S197	2670	127
774	S198	2655	257
775	S199	2640	127
776	S200	2625	257
777	S201	2610	127
778	S202	2595	257
779	S203	2580	127
780	S204	2565	257

PAD No.	PIN Name	X	Y
781	S205	2550	127
782	S206	2535	257
783	S207	2520	127
784	S208	2505	257
785	S209	2490	127
786	S210	2475	257
787	S211	2460	127
788	S212	2445	257
789	S213	2430	127
790	S214	2415	257
791	S215	2400	127
792	S216	2385	257
793	S217	2370	127
794	S218	2355	257
795	S219	2340	127
796	S220	2325	257
797	S221	2310	127
798	S222	2295	257
799	S223	2280	127
800	S224	2265	257
801	S225	2250	127
802	S226	2235	257
803	S227	2220	127
804	S228	2205	257
805	S229	2190	127
806	S230	2175	257
807	S231	2160	127
808	S232	2145	257
809	S233	2130	127
810	S234	2115	257
811	S235	2100	127
812	S236	2085	257
813	S237	2070	127
814	S238	2055	257

PAD No.	PIN Name	X	Y	PAD No.	PIN Name	X	Y
815	S239	2040	127	849	DUMMY	1530	127
816	S240	2025	257	850	DUMMY	1515	257
817	DUMMY	2010	127	851	DUMMY	1500	127
818	DUMMY	1995	257	852	DUMMY	1485	257
819	DUMMY	1980	127	853	DUMMY	1470	127
820	DUMMY	1965	257	854	DUMMY	1455	257
821	DUMMY	1950	127	855	DUMMY	1440	127
822	DUMMY	1935	257	856	DUMMY	1425	257
823	DUMMY	1920	127	857	DUMMY	1410	127
824	DUMMY	1905	257	858	DUMMY	1395	257
825	DUMMY	1890	127	859	DUMMY	1380	127
826	DUMMY	1875	257	860	DUMMY	1365	257
827	DUMMY	1860	127	861	DUMMY	1350	127
828	DUMMY	1845	257	862	DUMMY	1335	257
829	DUMMY	1830	127	863	DUMMY	1320	127
830	DUMMY	1815	257	864	DUMMY	1305	257
831	DUMMY	1800	127	865	DUMMY	1290	127
832	DUMMY	1785	257	866	DUMMY	1275	257
833	DUMMY	1770	127	867	DUMMY	1260	127
834	DUMMY	1755	257	868	DUMMY	1245	257
835	DUMMY	1740	127	869	DUMMY	1230	127
836	DUMMY	1725	257	870	DUMMY	1215	257
837	DUMMY	1710	127	871	DUMMY	1200	127
838	DUMMY	1695	257	872	DUMMY	1185	257
839	DUMMY	1680	127	873	DUMMY	1170	127
840	DUMMY	1665	257	874	DUMMY	1155	257
841	DUMMY	1650	127	875	DUMMY	1140	127
842	DUMMY	1635	257	876	DUMMY	1125	257
843	DUMMY	1620	127	877	DUMMY	1110	127
844	DUMMY	1605	257	878	DUMMY	1095	257
845	DUMMY	1590	127	879	DUMMY	1080	127
846	DUMMY	1575	257	880	DUMMY	1065	257
847	DUMMY	1560	127	881	DUMMY	1050	127
848	DUMMY	1545	257	882	DUMMY	1035	257

PAD No.	PIN Name	X	Y	PAD No.	PIN Name	X	Y
883	DUMMY	1020	127	917	DUMMY	510	127
884	DUMMY	1005	257	918	DUMMY	495	257
885	DUMMY	990	127	919	DUMMY	480	127
886	DUMMY	975	257	920	DUMMY	465	257
887	DUMMY	960	127	921	DUMMY	450	127
888	DUMMY	945	257	922	DUMMY	435	257
889	DUMMY	930	127	923	DUMMY	420	127
890	DUMMY	915	257	924	DUMMY	405	257
891	DUMMY	900	127	925	DUMMY	390	127
892	DUMMY	885	257	926	DUMMY	375	257
893	DUMMY	870	127	927	DUMMY	360	127
894	DUMMY	855	257	928	DUMMY	345	257
895	DUMMY	840	127	929	DUMMY	330	127
896	DUMMY	825	257	930	DUMMY	315	257
897	DUMMY	810	127	931	DUMMY	300	127
898	DUMMY	795	257	932	DUMMY	285	257
899	DUMMY	780	127	933	DUMMY	270	127
900	DUMMY	765	257	934	DUMMY	255	257
901	DUMMY	750	127	935	DUMMY	240	127
902	DUMMY	735	257	936	DUMMY	225	257
903	DUMMY	720	127	937	DUMMY	150	127
904	DUMMY	705	257	938	DUMMY	135	257
905	DUMMY	690	127	939	DUMMY	120	127
906	DUMMY	675	257	940	DUMMY	105	257
907	DUMMY	660	127	941	DUMMY	90	127
908	DUMMY	645	257	942	DUMMY	75	257
909	DUMMY	630	127	943	DUMMY	60	127
910	DUMMY	615	257	944	DUMMY	-15	257
911	DUMMY	600	127	945	DUMMY	-30	127
912	DUMMY	585	257	946	DUMMY	-45	257
913	DUMMY	570	127	947	DUMMY	-60	127
914	DUMMY	555	257	948	DUMMY	-75	257
915	DUMMY	540	127	949	DUMMY	-90	127
916	DUMMY	525	257	950	DUMMY	-105	257

PAD No.	PIN Name	X	Y	PAD No.	PIN Name	X	Y
951	DUMMY	-120	127	985	DUMMY	-630	127
952	DUMMY	-135	257	986	DUMMY	-645	257
953	DUMMY	-150	127	987	DUMMY	-660	127
954	DUMMY	-165	257	988	DUMMY	-675	257
955	DUMMY	-180	127	989	DUMMY	-690	127
956	DUMMY	-195	257	990	DUMMY	-705	257
957	DUMMY	-210	127	991	DUMMY	-720	127
958	DUMMY	-225	257	992	DUMMY	-735	257
959	DUMMY	-240	127	993	DUMMY	-750	127
960	DUMMY	-255	257	994	DUMMY	-765	257
961	DUMMY	-270	127	995	DUMMY	-780	127
962	DUMMY	-285	257	996	DUMMY	-795	257
963	DUMMY	-300	127	997	DUMMY	-810	127
964	DUMMY	-315	257	998	DUMMY	-825	257
965	DUMMY	-330	127	999	DUMMY	-840	127
966	DUMMY	-345	257	1000	DUMMY	-855	257
967	DUMMY	-360	127	1001	DUMMY	-870	127
968	DUMMY	-375	257	1002	DUMMY	-885	257
969	DUMMY	-390	127	1003	DUMMY	-900	127
970	DUMMY	-405	257	1004	DUMMY	-915	257
971	DUMMY	-420	127	1005	DUMMY	-930	127
972	DUMMY	-435	257	1006	DUMMY	-945	257
973	DUMMY	-450	127	1007	DUMMY	-960	127
974	DUMMY	-465	257	1008	DUMMY	-975	257
975	DUMMY	-480	127	1009	DUMMY	-990	127
976	DUMMY	-495	257	1010	DUMMY	-1005	257
977	DUMMY	-510	127	1011	DUMMY	-1020	127
978	DUMMY	-525	257	1012	DUMMY	-1035	257
979	DUMMY	-540	127	1013	DUMMY	-1050	127
980	DUMMY	-555	257	1014	DUMMY	-1065	257
981	DUMMY	-570	127	1015	DUMMY	-1080	127
982	DUMMY	-585	257	1016	DUMMY	-1095	257
983	DUMMY	-600	127	1017	DUMMY	-1110	127
984	DUMMY	-615	257	1018	DUMMY	-1125	257



PAD No.	PIN Name	X	Y	PAD No.	PIN Name	X	Y
1019	DUMMY	-1140	127	1053	DUMMY	-1650	127
1020	DUMMY	-1155	257	1054	DUMMY	-1665	257
1021	DUMMY	-1170	127	1055	DUMMY	-1680	127
1022	DUMMY	-1185	257	1056	DUMMY	-1695	257
1023	DUMMY	-1200	127	1057	DUMMY	-1710	127
1024	DUMMY	-1215	257	1058	DUMMY	-1725	257
1025	DUMMY	-1230	127	1059	DUMMY	-1740	127
1026	DUMMY	-1245	257	1060	DUMMY	-1755	257
1027	DUMMY	-1260	127	1061	DUMMY	-1770	127
1028	DUMMY	-1275	257	1062	DUMMY	-1785	257
1029	DUMMY	-1290	127	1063	DUMMY	-1800	127
1030	DUMMY	-1305	257	1064	S241	-1815	257
1031	DUMMY	-1320	127	1065	S242	-1830	127
1032	DUMMY	-1335	257	1066	S243	-1845	257
1033	DUMMY	-1350	127	1067	S244	-1860	127
1034	DUMMY	-1365	257	1068	S245	-1875	257
1035	DUMMY	-1380	127	1069	S246	-1890	127
1036	DUMMY	-1395	257	1070	S247	-1905	257
1037	DUMMY	-1410	127	1071	S248	-1920	127
1038	DUMMY	-1425	257	1072	S249	-1935	257
1039	DUMMY	-1440	127	1073	S250	-1950	127
1040	DUMMY	-1455	257	1074	S251	-1965	257
1041	DUMMY	-1470	127	1075	S252	-1980	127
1042	DUMMY	-1485	257	1076	S253	-1995	257
1043	DUMMY	-1500	127	1077	S254	-2010	127
1044	DUMMY	-1515	257	1078	S255	-2025	257
1045	DUMMY	-1530	127	1079	S256	-2040	127
1046	DUMMY	-1545	257	1080	S257	-2055	257
1047	DUMMY	-1560	127	1081	S258	-2070	127
1048	DUMMY	-1575	257	1082	S259	-2085	257
1049	DUMMY	-1590	127	1083	S260	-2100	127
1050	DUMMY	-1605	257	1084	S261	-2115	257
1051	DUMMY	-1620	127	1085	S262	-2130	127
1052	DUMMY	-1635	257	1086	S263	-2145	257

PAD No.	PIN Name	X	Y	PAD No.	PIN Name	X	Y
1087	S264	-2160	127	1121	S298	-2670	127
1088	S265	-2175	257	1122	S299	-2685	257
1089	S266	-2190	127	1123	S300	-2700	127
1090	S267	-2205	257	1124	S301	-2715	257
1091	S268	-2220	127	1125	S302	-2730	127
1092	S269	-2235	257	1126	S303	-2745	257
1093	S270	-2250	127	1127	S304	-2760	127
1094	S271	-2265	257	1128	S305	-2775	257
1095	S272	-2280	127	1129	S306	-2790	127
1096	S273	-2295	257	1130	S307	-2805	257
1097	S274	-2310	127	1131	S308	-2820	127
1098	S275	-2325	257	1132	S309	-2835	257
1099	S276	-2340	127	1133	S310	-2850	127
1100	S277	-2355	257	1134	S311	-2865	257
1101	S278	-2370	127	1135	S312	-2880	127
1102	S279	-2385	257	1136	S313	-2895	257
1103	S280	-2400	127	1137	S314	-2910	127
1104	S281	-2415	257	1138	S315	-2925	257
1105	S282	-2430	127	1139	S316	-2940	127
1106	S283	-2445	257	1140	S317	-2955	257
1107	S284	-2460	127	1141	S318	-2970	127
1108	S285	-2475	257	1142	S319	-2985	257
1109	S286	-2490	127	1143	S320	-3000	127
1110	S287	-2505	257	1144	S321	-3015	257
1111	S288	-2520	127	1145	S322	-3030	127
1112	S289	-2535	257	1146	S323	-3045	257
1113	S290	-2550	127	1147	S324	-3060	127
1114	S291	-2565	257	1148	S325	-3075	257
1115	S292	-2580	127	1149	S326	-3090	127
1116	S293	-2595	257	1150	S327	-3105	257
1117	S294	-2610	127	1151	S328	-3120	127
1118	S295	-2625	257	1152	S329	-3135	257
1119	S296	-2640	127	1153	S330	-3150	127
1120	S297	-2655	257	1154	S331	-3165	257

PAD No.	PIN Name	X	Y	PAD No.	PIN Name	X	Y
1155	S332	-3180	127	1189	S366	-3690	127
1156	S333	-3195	257	1190	S367	-3705	257
1157	S334	-3210	127	1191	S368	-3720	127
1158	S335	-3225	257	1192	S369	-3735	257
1159	S336	-3240	127	1193	S370	-3750	127
1160	S337	-3255	257	1194	S371	-3765	257
1161	S338	-3270	127	1195	S372	-3780	127
1162	S339	-3285	257	1196	S373	-3795	257
1163	S340	-3300	127	1197	S374	-3810	127
1164	S341	-3315	257	1198	S375	-3825	257
1165	S342	-3330	127	1199	S376	-3840	127
1166	S343	-3345	257	1200	S377	-3855	257
1167	S344	-3360	127	1201	S378	-3870	127
1168	S345	-3375	257	1202	S379	-3885	257
1169	S346	-3390	127	1203	S380	-3900	127
1170	S347	-3405	257	1204	S381	-3915	257
1171	S348	-3420	127	1205	S382	-3930	127
1172	S349	-3435	257	1206	S383	-3945	257
1173	S350	-3450	127	1207	S384	-3960	127
1174	S351	-3465	257	1208	S385	-3975	257
1175	S352	-3480	127	1209	S386	-3990	127
1176	S353	-3495	257	1210	S387	-4005	257
1177	S354	-3510	127	1211	S388	-4020	127
1178	S355	-3525	257	1212	S389	-4035	257
1179	S356	-3540	127	1213	S390	-4050	127
1180	S357	-3555	257	1214	S391	-4065	257
1181	S358	-3570	127	1215	S392	-4080	127
1182	S359	-3585	257	1216	S393	-4095	257
1183	S360	-3600	127	1217	S394	-4110	127
1184	S361	-3615	257	1218	S395	-4125	257
1185	S362	-3630	127	1219	S396	-4140	127
1186	S363	-3645	257	1220	S397	-4155	257
1187	S364	-3660	127	1221	S398	-4170	127
1188	S365	-3675	257	1222	S399	-4185	257

PAD No.	PIN Name	X	Y	PAD No.	PIN Name	X	Y
1223	S400	-4200	127	1257	S434	-4710	127
1224	S401	-4215	257	1258	S435	-4725	257
1225	S402	-4230	127	1259	S436	-4740	127
1226	S403	-4245	257	1260	S437	-4755	257
1227	S404	-4260	127	1261	S438	-4770	127
1228	S405	-4275	257	1262	S439	-4785	257
1229	S406	-4290	127	1263	S440	-4800	127
1230	S407	-4305	257	1264	S441	-4815	257
1231	S408	-4320	127	1265	S442	-4830	127
1232	S409	-4335	257	1266	S443	-4845	257
1233	S410	-4350	127	1267	S444	-4860	127
1234	S411	-4365	257	1268	S445	-4875	257
1235	S412	-4380	127	1269	S446	-4890	127
1236	S413	-4395	257	1270	S447	-4905	257
1237	S414	-4410	127	1271	S448	-4920	127
1238	S415	-4425	257	1272	S449	-4935	257
1239	S416	-4440	127	1273	S450	-4950	127
1240	S417	-4455	257	1274	S451	-4965	257
1241	S418	-4470	127	1275	S452	-4980	127
1242	S419	-4485	257	1276	S453	-4995	257
1243	S420	-4500	127	1277	S454	-5010	127
1244	S421	-4515	257	1278	S455	-5025	257
1245	S422	-4530	127	1279	S456	-5040	127
1246	S423	-4545	257	1280	S457	-5055	257
1247	S424	-4560	127	1281	S458	-5070	127
1248	S425	-4575	257	1282	S459	-5085	257
1249	S426	-4590	127	1283	S460	-5100	127
1250	S427	-4605	257	1284	S461	-5115	257
1251	S428	-4620	127	1285	S462	-5130	127
1252	S429	-4635	257	1286	S463	-5145	257
1253	S430	-4650	127	1287	S464	-5160	127
1254	S431	-4665	257	1288	S465	-5175	257
1255	S432	-4680	127	1289	S466	-5190	127
1256	S433	-4695	257	1290	S467	-5205	257

PAD No.	PIN Name	X	Y	PAD No.	PIN Name	X	Y
1291	S468	-5220	127	1325	G443	-6585	257
1292	S469	-5235	257	1326	G441	-6600	127
1293	S470	-5250	127	1327	G439	-6615	257
1294	S471	-5265	257	1328	G437	-6630	127
1295	S472	-5280	127	1329	G435	-6645	257
1296	S473	-5295	257	1330	G433	-6660	127
1297	S474	-5310	127	1331	G431	-6675	257
1298	S475	-5325	257	1332	G429	-6690	127
1299	S476	-5340	127	1333	G427	-6705	257
1300	S477	-5355	257	1334	G425	-6720	127
1301	S478	-5370	127	1335	G423	-6735	257
1302	S479	-5385	257	1336	G421	-6750	127
1303	S480	-5400	127	1337	G419	-6765	257
1304	DUMMY	-5700	127	1338	G417	-6780	127
1305	DUMMY	-5880	127	1339	G415	-6795	257
1306	DUMMY	-6090	127	1340	G413	-6810	127
1307	G479	-6315	257	1341	G411	-6825	257
1308	G477	-6330	127	1342	G409	-6840	127
1309	G475	-6345	257	1343	G407	-6855	257
1310	G473	-6360	127	1344	G405	-6870	127
1311	G471	-6375	257	1345	G403	-6885	257
1312	G469	-6390	127	1346	G401	-6900	127
1313	G467	-6405	257	1347	G399	-6915	257
1314	G465	-6420	127	1348	G397	-6930	127
1315	G463	-6435	257	1349	G395	-6945	257
1316	G461	-6450	127	1350	G393	-6960	127
1317	G459	-6465	257	1351	G391	-6975	257
1318	G457	-6480	127	1352	G389	-6990	127
1319	G455	-6495	257	1353	G387	-7005	257
1320	G453	-6510	127	1354	G385	-7020	127
1321	G451	-6525	257	1355	G383	-7035	257
1322	G449	-6540	127	1356	G381	-7050	127
1323	G447	-6555	257	1357	G379	-7065	257
1324	G445	-6570	127	1358	G377	-7080	127

PAD No.	PIN Name	X	Y	PAD No.	PIN Name	X	Y
1359	G375	-7095	257	1393	G307	-7605	257
1360	G373	-7110	127	1394	G305	-7620	127
1361	G371	-7125	257	1395	G303	-7635	257
1362	G369	-7140	127	1396	G301	-7650	127
1363	G367	-7155	257	1397	G299	-7665	257
1364	G365	-7170	127	1398	G297	-7680	127
1365	G363	-7185	257	1399	G295	-7695	257
1366	G361	-7200	127	1400	G293	-7710	127
1367	G359	-7215	257	1401	G291	-7725	257
1368	G357	-7230	127	1402	G289	-7740	127
1369	G355	-7245	257	1403	G287	-7755	257
1370	G353	-7260	127	1404	G285	-7770	127
1371	G351	-7275	257	1405	G283	-7785	257
1372	G349	-7290	127	1406	G281	-7800	127
1373	G347	-7305	257	1407	G279	-7815	257
1374	G345	-7320	127	1408	G277	-7830	127
1375	G343	-7335	257	1409	G275	-7845	257
1376	G341	-7350	127	1410	G273	-7860	127
1377	G339	-7365	257	1411	G271	-7875	257
1378	G337	-7380	127	1412	G269	-7890	127
1379	G335	-7395	257	1413	G267	-7905	257
1380	G333	-7410	127	1414	G265	-7920	127
1381	G331	-7425	257	1415	G263	-7935	257
1382	G329	-7440	127	1416	G261	-7950	127
1383	G327	-7455	257	1417	G259	-7965	257
1384	G325	-7470	127	1418	G257	-7980	127
1385	G323	-7485	257	1419	G255	-7995	257
1386	G321	-7500	127	1420	G253	-8010	127
1387	G319	-7515	257	1421	G251	-8025	257
1388	G317	-7530	127	1422	G249	-8040	127
1389	G315	-7545	257	1423	G247	-8055	257
1390	G313	-7560	127	1424	G245	-8070	127
1391	G311	-7575	257	1425	G243	-8085	257
1392	G309	-7590	127	1426	G241	-8100	127

PAD No.	PIN Name	X	Y	PAD No.	PIN Name	X	Y
1427	G239	-8115	257	1461	G171	-8625	257
1428	G237	-8130	127	1462	G169	-8640	127
1429	G235	-8145	257	1463	G167	-8655	257
1430	G233	-8160	127	1464	G165	-8670	127
1431	G231	-8175	257	1465	G163	-8685	257
1432	G229	-8190	127	1466	G161	-8700	127
1433	G227	-8205	257	1467	G159	-8715	257
1434	G225	-8220	127	1468	G157	-8730	127
1435	G223	-8235	257	1469	G155	-8745	257
1436	G221	-8250	127	1470	G153	-8760	127
1437	G219	-8265	257	1471	G151	-8775	257
1438	G217	-8280	127	1472	G149	-8790	127
1439	G215	-8295	257	1473	G147	-8805	257
1440	G213	-8310	127	1474	G145	-8820	127
1441	G211	-8325	257	1475	G143	-8835	257
1442	G209	-8340	127	1476	G141	-8850	127
1443	G207	-8355	257	1477	G139	-8865	257
1444	G205	-8370	127	1478	G137	-8880	127
1445	G203	-8385	257	1479	G135	-8895	257
1446	G201	-8400	127	1480	G133	-8910	127
1447	G199	-8415	257	1481	G131	-8925	257
1448	G197	-8430	127	1482	G129	-8940	127
1449	G195	-8445	257	1483	G127	-8955	257
1450	G193	-8460	127	1484	G125	-8970	127
1451	G191	-8475	257	1485	G123	-8985	257
1452	G189	-8490	127	1486	G121	-9000	127
1453	G187	-8505	257	1487	G119	-9015	257
1454	G185	-8520	127	1488	G117	-9030	127
1455	G183	-8535	257	1489	G115	-9045	257
1456	G181	-8550	127	1490	G113	-9060	127
1457	G179	-8565	257	1491	G111	-9075	257
1458	G177	-8580	127	1492	G109	-9090	127
1459	G175	-8595	257	1493	G107	-9105	257
1460	G173	-8610	127	1494	G105	-9120	127

PAD No.	PIN Name	X	Y	PAD No.	PIN Name	X	Y
1495	G103	-9135	257	1529	G35	-9645	257
1496	G101	-9150	127	1530	G33	-9660	127
1497	G99	-9165	257	1531	G31	-9675	257
1498	G97	-9180	127	1532	G29	-9690	127
1499	G95	-9195	257	1533	G27	-9705	257
1500	G93	-9210	127	1534	G25	-9720	127
1501	G91	-9225	257	1535	G23	-9735	257
1502	G89	-9240	127	1536	G21	-9750	127
1503	G87	-9255	257	1537	G19	-9765	257
1504	G85	-9270	127	1538	G17	-9780	127
1505	G83	-9285	257	1539	G15	-9795	257
1506	G81	-9300	127	1540	G13	-9810	127
1507	G79	-9315	257	1541	G11	-9825	257
1508	G77	-9330	127	1542	G9	-9840	127
1509	G75	-9345	257	1543	G7	-9855	257
1510	G73	-9360	127	1544	G5	-9870	127
1511	G71	-9375	257	1545	G3	-9885	257
1512	G69	-9390	127	1546	G1	-9900	127
1513	G67	-9405	257	1547	DUMMY	-9930	257
1514	G65	-9420	127	1548	DUMMY	-9945	127
1515	G63	-9435	257	1549			
1516	G61	-9450	127	1550			
1517	G59	-9465	257	1551			
1518	G57	-9480	127	1552			
1519	G55	-9495	257	1553			
1520	G53	-9510	127	1554			
1521	G51	-9525	257	1555			
1522	G49	-9540	127	1556			
1523	G47	-9555	257	1557			
1524	G45	-9570	127	1558			
1525	G43	-9585	257	1559			
1526	G41	-9600	127	1560			
1527	G39	-9615	257	1561			
1528	G37	-9630	127	1562			



5. BLOCK DIAGRAM

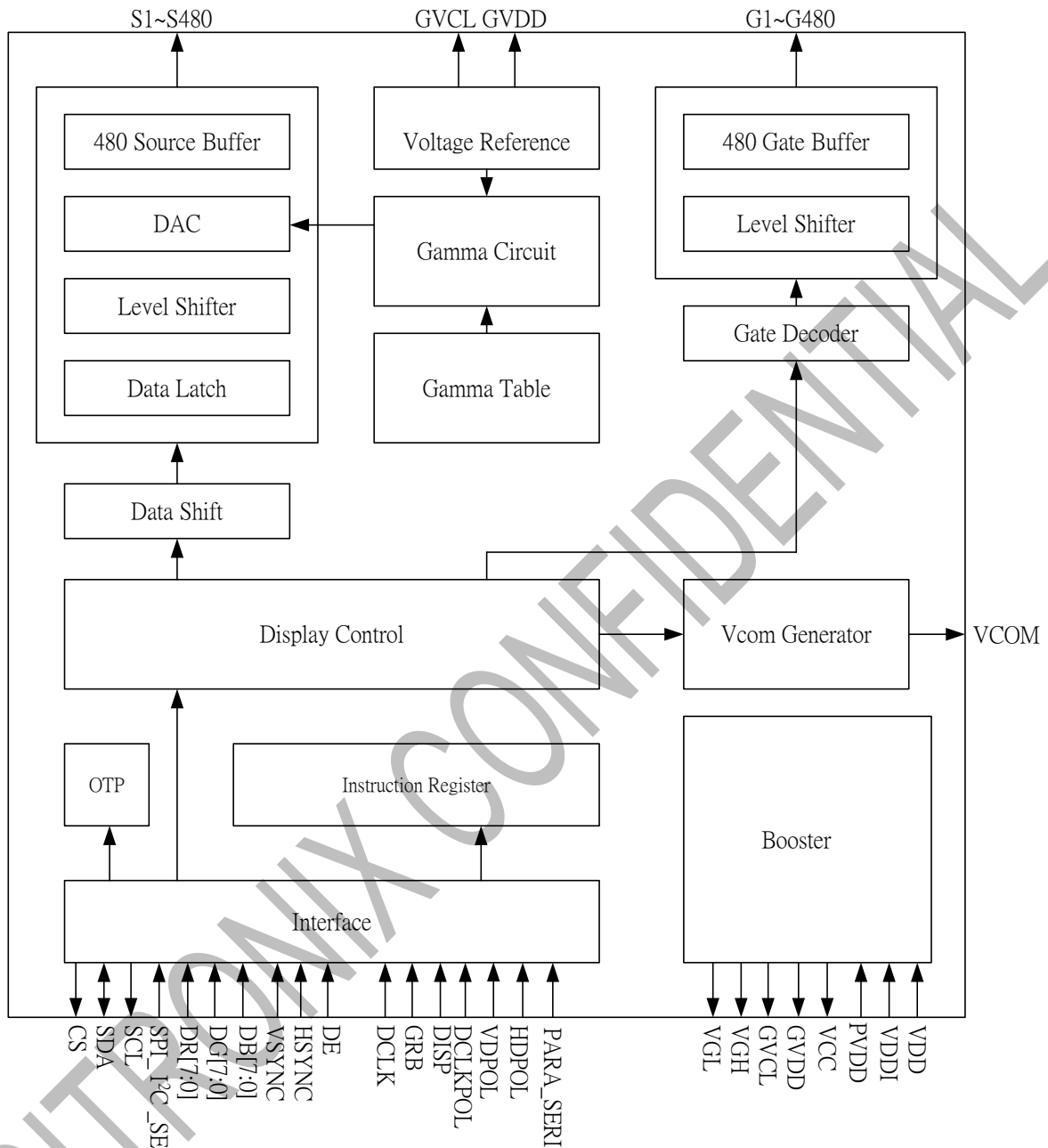

6. PIN DESCRIPTION

6.1 Pin Function

Name	Type	Description						
3-Wire SPI / I <sup>2</sup> C Interface Pins								
SPI_I <sup>2</sup> C_SEL	I	3-wire SPI and I <sup>2</sup> C interface control.						
		<table border="1"> <thead> <tr> <th>SPI_I<sup>2</sup>C_SEL</th> <th>Function Description</th> </tr> </thead> <tbody> <tr> <td>L</td> <td>I<sup>2</sup>C interface</td> </tr> <tr> <td>H</td> <td>3-wire SPI interface</td> </tr> </tbody> </table>	SPI_I <sup>2</sup> C_SEL	Function Description	L	I <sup>2</sup> C interface	H	3-wire SPI interface
		SPI_I <sup>2</sup> C_SEL	Function Description					
L	I <sup>2</sup> C interface							
H	3-wire SPI interface							
CS	I	Serial communication chip selection. CS is not used in I <sup>2</sup> C interface and should be connected to "H".						
SDA	I/O	Serial communication data input and output.						
SCL	I	Serial communication clock input.						
Control Pins								
PARA_SERI	I	Set parallel or serial RGB interface.						
		<table border="1"> <thead> <tr> <th>PARA_SERI</th> <th>Function Description</th> </tr> </thead> <tbody> <tr> <td>L</td> <td>Serial 8 bit RGB interface</td> </tr> <tr> <td>H</td> <td>Parallel 24 bit RGB interface</td> </tr> </tbody> </table>	PARA_SERI	Function Description	L	Serial 8 bit RGB interface	H	Parallel 24 bit RGB interface
		PARA_SERI	Function Description					
L	Serial 8 bit RGB interface							
H	Parallel 24 bit RGB interface							
HDIR	I	Horizontal scan direction control pin. This pin must be connected to "H" or "L" according to system application.						
		<table border="1"> <thead> <tr> <th>HDIR</th> <th>Function Description</th> </tr> </thead> <tbody> <tr> <td>L</td> <td>From right to left</td> </tr> <tr> <td>H</td> <td>From left to right</td> </tr> </tbody> </table>	HDIR	Function Description	L	From right to left	H	From left to right
		HDIR	Function Description					
L	From right to left							
H	From left to right							
VDIR	I	Vertical scan direction control pin. This pin must be connected to "H" or "L" according to system application.						
		<table border="1"> <thead> <tr> <th>VDIR</th> <th>Function Description</th> </tr> </thead> <tbody> <tr> <td>L</td> <td>From down to up.</td> </tr> <tr> <td>H</td> <td>From up to down.</td> </tr> </tbody> </table>	VDIR	Function Description	L	From down to up.	H	From up to down.
		VDIR	Function Description					
L	From down to up.							
H	From up to down.							
VDPOL	I	VDPOL sets VSYNC polarity in RGB interface.						
		<table border="1"> <thead> <tr> <th>DCLKPOL</th> <th>Function Description</th> </tr> </thead> <tbody> <tr> <td>L</td> <td>HSYNC polarity: positive</td> </tr> <tr> <td>H</td> <td>HSYNC polarity: negative</td> </tr> </tbody> </table>	DCLKPOL	Function Description	L	HSYNC polarity: positive	H	HSYNC polarity: negative
		DCLKPOL	Function Description					
L	HSYNC polarity: positive							
H	HSYNC polarity: negative							
HDPOL	I	HDPOL sets HSYNC polarity in RGB interface.						
		<table border="1"> <thead> <tr> <th>HCLKPOL</th> <th>Function Description</th> </tr> </thead> <tbody> <tr> <td>L</td> <td>HSYNC polarity: positive</td> </tr> <tr> <td>H</td> <td>HSYNC polarity: negative</td> </tr> </tbody> </table>	HCLKPOL	Function Description	L	HSYNC polarity: positive	H	HSYNC polarity: negative
		HCLKPOL	Function Description					
L	HSYNC polarity: positive							
H	HSYNC polarity: negative							

Name	Type	Description								
DCLKPOL	I	VDPOL sets DCLK polarity in RGB interface.								
		<table border="1"> <thead> <tr> <th>VDLKPOL</th> <th>Function Description</th> </tr> </thead> <tbody> <tr> <td>L</td> <td>VSYNC polarity: positive</td> </tr> <tr> <td>H</td> <td>VSYNC polarity: negative</td> </tr> </tbody> </table>	VDLKPOL	Function Description	L	VSYNC polarity: positive	H	VSYNC polarity: negative		
		VDLKPOL	Function Description							
L	VSYNC polarity: positive									
H	VSYNC polarity: negative									
GRB	I	Global reset pin. When GRB is "L", internal initialization procedure is executed.								
DISP	I	DISP sets the display mode.								
		<table border="1"> <thead> <tr> <th>DISP</th> <th>Function Description</th> </tr> </thead> <tbody> <tr> <td>L</td> <td>Standby mode</td> </tr> <tr> <td>H</td> <td>Normal display mode</td> </tr> </tbody> </table>	DISP	Function Description	L	Standby mode	H	Normal display mode		
		DISP	Function Description							
L	Standby mode									
H	Normal display mode									
AUTODL	I	OTP trim function control pin.								
		<table border="1"> <thead> <tr> <th>AUTODL</th> <th>Function Description</th> </tr> </thead> <tbody> <tr> <td>L</td> <td>Disable auto-refresh function</td> </tr> <tr> <td>H</td> <td>Enable auto-refresh function</td> </tr> </tbody> </table>	AUTODL	Function Description	L	Disable auto-refresh function	H	Enable auto-refresh function		
		AUTODL	Function Description							
L	Disable auto-refresh function									
H	Enable auto-refresh function									
ENPROG	I	OTP program control pin.								
		<table border="1"> <thead> <tr> <th>ENPROG</th> <th>Function Description</th> </tr> </thead> <tbody> <tr> <td>L</td> <td>Disable OTP program function</td> </tr> <tr> <td>H</td> <td>Enable OTP program function</td> </tr> </tbody> </table>	ENPROG	Function Description	L	Disable OTP program function	H	Enable OTP program function		
		ENPROG	Function Description							
L	Disable OTP program function									
H	Enable OTP program function									
BIST_EN	I	BIST function control pin.								
		<table border="1"> <thead> <tr> <th>BIST_EN</th> <th>Function Description</th> </tr> </thead> <tbody> <tr> <td>L</td> <td>Disable BIST function</td> </tr> <tr> <td>H</td> <td>Enable BIST function</td> </tr> </tbody> </table>	BIST_EN	Function Description	L	Disable BIST function	H	Enable BIST function		
		BIST_EN	Function Description							
L	Disable BIST function									
H	Enable BIST function									
Input Interface Pins										
DR[7:0] DG[7:0] DB[7:0]	I	RGB interface data input pins.								
		<table border="1"> <thead> <tr> <th colspan="2">Function Description</th> </tr> </thead> <tbody> <tr> <td>DR[7:0]</td> <td>8 bit data bus display red data. DR[7:0] are not used in 8-bit RGB interface and should be connected to "L".</td> </tr> <tr> <td>DG[7:0]</td> <td>8 bit data bus display green data. DG[7:0] are used in 8-bit RGB interface.</td> </tr> <tr> <td>DB[7:0]</td> <td>8 bit data bus display blue data. DB[7:0] are not used in 8-bit RGB interface and should be connected to "L".</td> </tr> </tbody> </table>	Function Description		DR[7:0]	8 bit data bus display red data. DR[7:0] are not used in 8-bit RGB interface and should be connected to "L".	DG[7:0]	8 bit data bus display green data. DG[7:0] are used in 8-bit RGB interface.	DB[7:0]	8 bit data bus display blue data. DB[7:0] are not used in 8-bit RGB interface and should be connected to "L".
		Function Description								
		DR[7:0]	8 bit data bus display red data. DR[7:0] are not used in 8-bit RGB interface and should be connected to "L".							
DG[7:0]	8 bit data bus display green data. DG[7:0] are used in 8-bit RGB interface.									
DB[7:0]	8 bit data bus display blue data. DB[7:0] are not used in 8-bit RGB interface and should be connected to "L".									
DCLK	I	Pixel clock input pin.								
HSYNC	I	Horizontal sync signal, default is negative polarity.								
VSYNC	I	Vertical sync signal, default is negative polarity.								
DE	I	Data input enable. Display access is enabled when DE is "H".								
Source / Gate Driver Pins										

Name	Type	Description
S1~S480	O	Source driver output signals.
G1~G480	O	Gate driver output signals.
VCOM Generator Pin		
VCOM	O	Power supply for the TFT-LCD common electrode.
Power Supply Pins		
VDD	P	Power supply for analog circuit.
VDDI	P	Power supply for digital I/O pins.
PVDD	P	Power supply for charge pump circuit.
DGND	P	Ground pin for digital circuit.
AGND	P	Ground pin for analog circuit.
PGND	P	Ground pin for charge pump circuit.
Power Circuit Pins		
AVDD	C	DC/DC converter for positive source OP-AMP driver.
AVCL	C	DC/DC converter for negative source OP-AMP driver.
VGH	C	Positive power supply for gate driver.
VGL	C	Negative power supply for gate driver.
GVDD	PO	Positive voltage output of grayscale power.
GVCL	PO	Negative voltage output of grayscale power.
Test Pins		
VGSP	T	Monitor pin of internal VCOM offset.
VCC	T	Reserved for testing only, please leave those pins open.
VCCA	T	Reserved for testing only, please leave those pins open.
AVDD1	T	Reserved for testing only, please leave those pins open.
AVCL1	T	Reserved for testing only, please leave those pins open.
VPP	T	Reserved for testing only, please leave this pin open.
TEST_IN[14:0]	T	Reserved for testing only, please leave those pins open.
TESTI[2:1]	T	Reserved for testing only, please leave those pins connect to "L".
TESTOUT[7:0]	T	Reserved for testing only, please leave those pins open.
TESTO[2:1]	T	Reserved for testing only, please leave it open.

Note: 1. I: input, O: output, I/O: input/output, P: power input, PO: power out, D: dummy, T: test pin, C: capacitor pin

2. If hardware pin is not used, please fix to "H" by VDDI or "L" by DGND

7. COMMUNICATION INTERFACE

7.1 3-wire Serial Interface

R/W: Read/Write mode control bit.  
 R/W=1: Read mode  
 R/W=0: Write mode

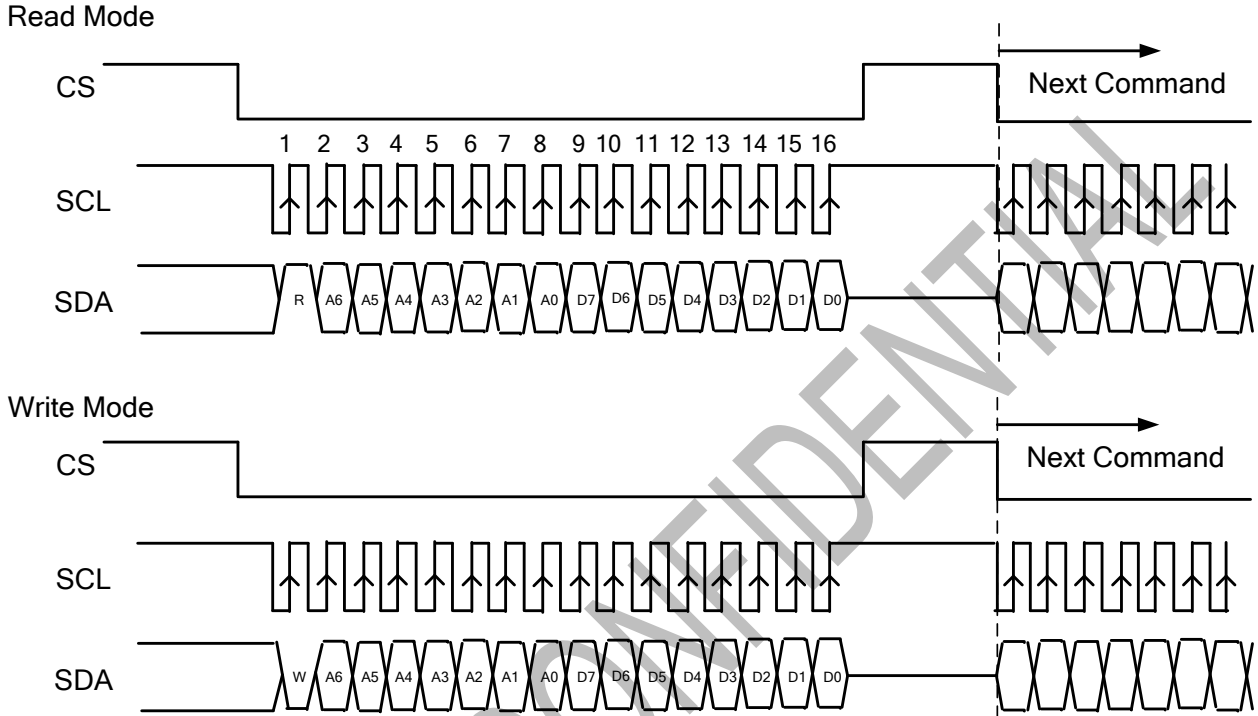

- a. Each serial command consists of 16 bits of data which is loaded one bit a time at the rising edge of serial clock SCL.
- b. Command loading operation starts from the falling edge of CS and is completed at the next rising edge of CS.
- c. The serial control block is operational after power on reset, but commands are established by the VSYNC signal. If command is transferred multiple times for the same register, the last command before the VSYNC signal is valid.
- d. If less than 16 bits of SCL are input while CS is low, the transferred data is ignored.
- e. If 16 bits or more of SCL are input while CS is low, the previous 16 bits of transferred data before then rising edge of CS pulse are valid data.
- f. Serial block operates with the SCL clock
- g. Serial data can be accepted in the power save mode.
- h. After power on reset or GRB reset, it is required 100ms delay to begin SPI communication.

### 7.2 I<sup>2</sup>C Interface

The I<sup>2</sup>C Interface is bi-directional two-line communication between different ICs or modules. The two lines are a Serial Data line (SDA) and a Serial Clock line (SCL). Both lines have built-in pull up resistor which drives SDA and SCL to high when the bus is not busy. Data transfer can be initiated only when the bus is not busy.

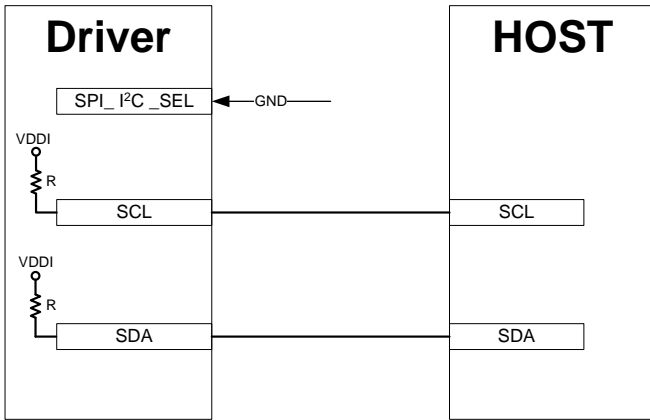

#### 7.2.1 Bit Transfer

One data bit is transferred during each clock pulse. The data on the SDA line must remain stable during the HIGH period of the clock pulse because changes of SDA line at this time will be interpreted as START or STOP. Bit transfer is illustrated as follows.

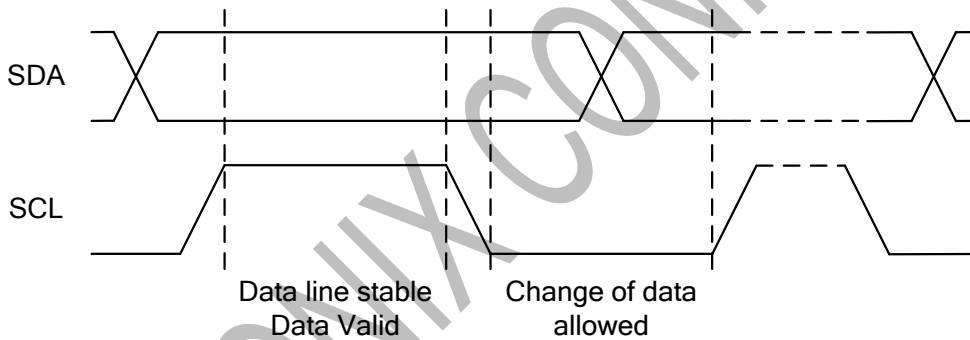

#### 7.2.2 START and STOP Conditions

Both SDA and SCL lines remain HIGH when the bus is not busy. A HIGH-to-LOW transition of SDA, while SCL is HIGH is defined as the START condition (S). A LOW-to-HIGH transition of SDA while SCL is HIGH is defined as the STOP condition (P). The START and STOP conditions are illustrated as follows.

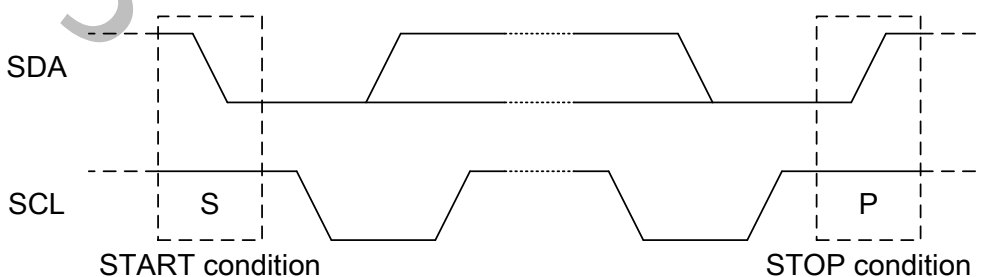

7.2.3 System Configuration

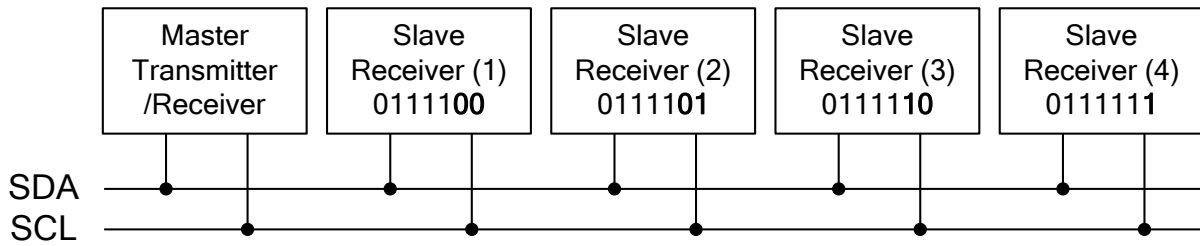

The system configuration is illustrated above and some word-definitions are explained below:

- a. Transmitter: the device which sends the data to the bus.
- b. Receiver: the device which receives the data from the bus.
- c. Master: the device which initiates a transfer generates clock signals and terminates a transfer.
- d. Slave: the device which is addressed by a master.
- e. Multi-Master: more than one master can attempt to control the bus at the same time without corrupting the message.
- f. Arbitration: the procedure to ensure that, if more than one master tries to control the bus simultaneously, only one is allowed to do so and the message is not corrupted.
- g. Synchronization: procedure to synchronize the clock signals of two or more devices.

7.2.4 Acknowledgment

Each byte of eight bits is followed by an acknowledge-bit. The acknowledge-bit is a HIGH signal put on SDA by the transmitter during the time when the master generates an extra acknowledge-related clock pulse. A slave receiver which is addressed must generate an acknowledge-bit after the reception of each byte. A master receiver must also generate an acknowledge-bit after the reception of each byte that has been clocked out of the slave transmitter. The device that acknowledges must pull-down the SDA line during the acknowledge-clock pulse, so that the SDA line is stable LOW during the HIGH period of the acknowledge-related clock pulse (set-up and hold times must be taken into consideration). A master receiver must signal an end-of-data to the slave transmitter by not generating an acknowledge-bit on the last byte that has been clocked out of the slave. In this event the transmitter must leave the data line HIGH to enable the master to generate a STOP condition. Acknowledgement on the I<sup>2</sup>C Interface is illustrated as follows.

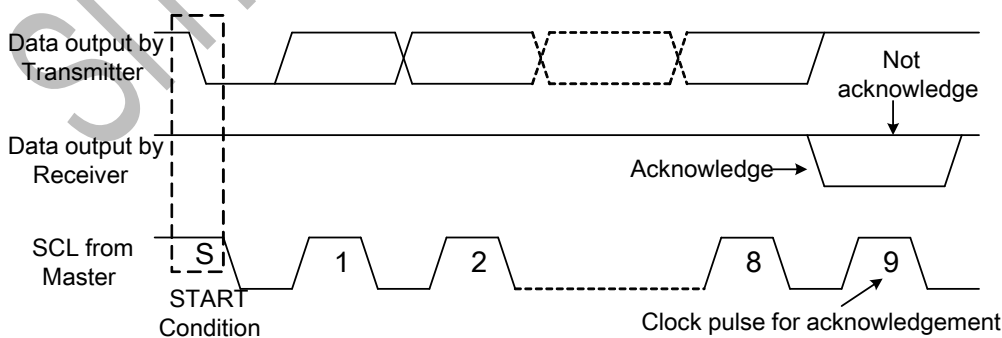

### 7.2.5 I<sup>2</sup>C Interface Protocol

The driver supports command/data write to addressed slaves on the bus. Before any data is transmitted on the I<sup>2</sup>C Interface, the device which should respond is addressed first. The default slave address is 0111100b and the three times I<sup>2</sup>C address could be OTP programming.

The sequence is initiated with a START condition (S) from the I<sup>2</sup>C Interface master, which is followed by the slave address. All slaves with the corresponding address acknowledge in parallel, all the others will ignore the I<sup>2</sup>C Interface transfer. After acknowledgement, one or more command or data words are followed and define the status of the addressed slaves.

Only the addressed slave makes the acknowledgement after each byte. At the end of the transmission the bus master issues a STOP condition (P). If no acknowledge is generated by the master after a byte, the driver stops transferring data to the master. The register write/ read transference sequence are described as follows.

#### Write Mode (R/W="0")

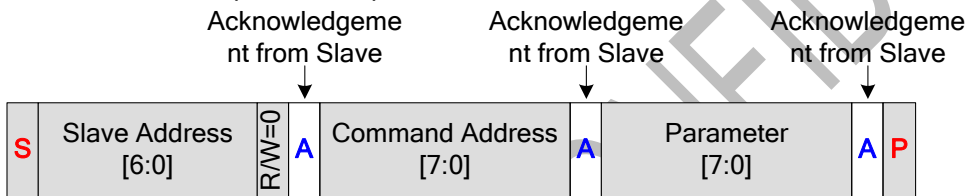

#### Read Mode (R/W="1")

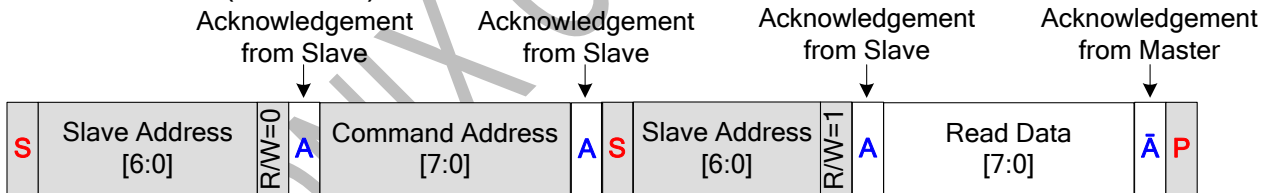

- S: start condition
- P: stop condition
- A: acknowledge
- Ā: no-acknowledge
- master to slave
- slave to master



7.3 RGB Interface

7.3.1 SYNC Mode

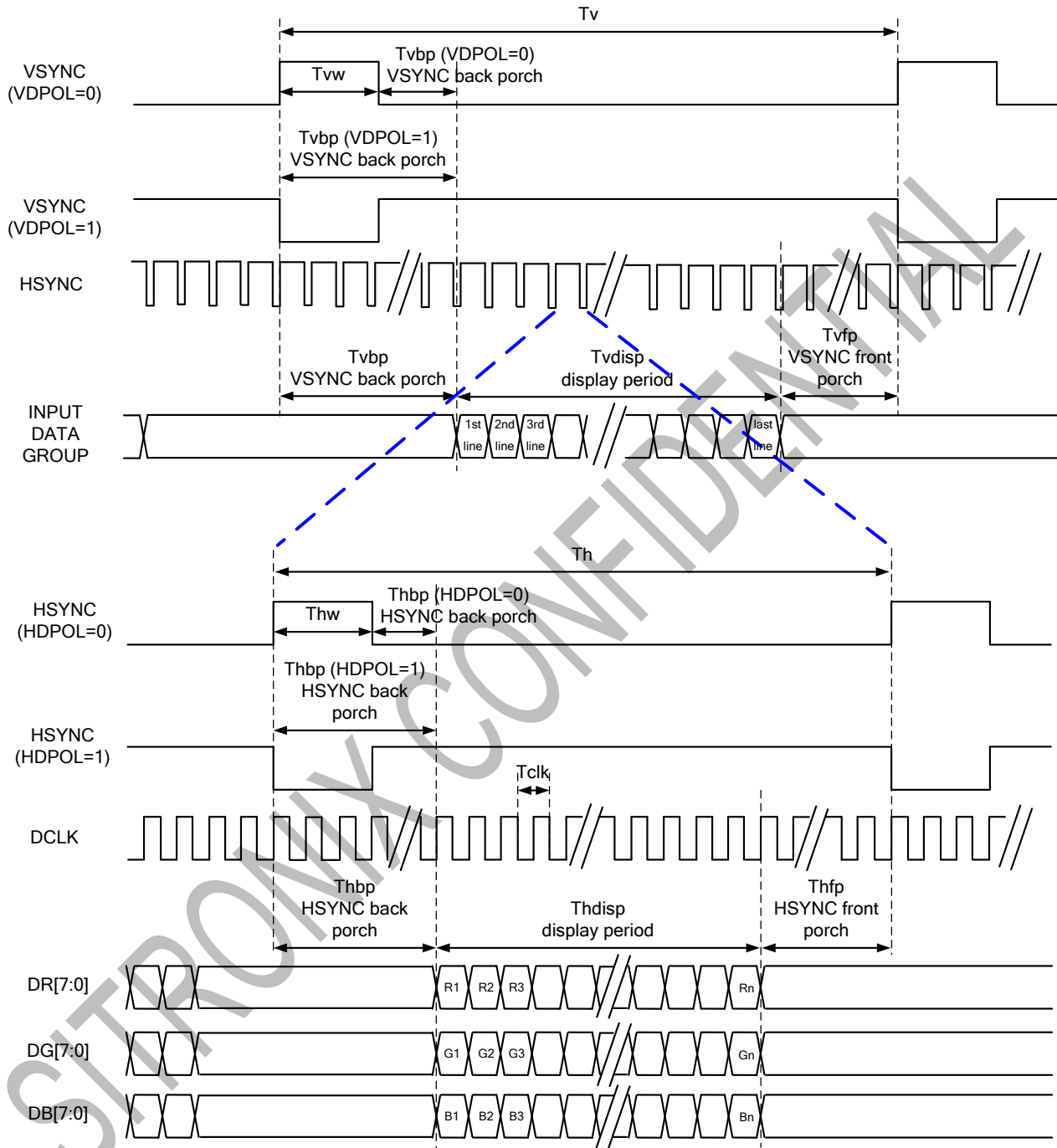

7.3.2 SYNC-DE Mode

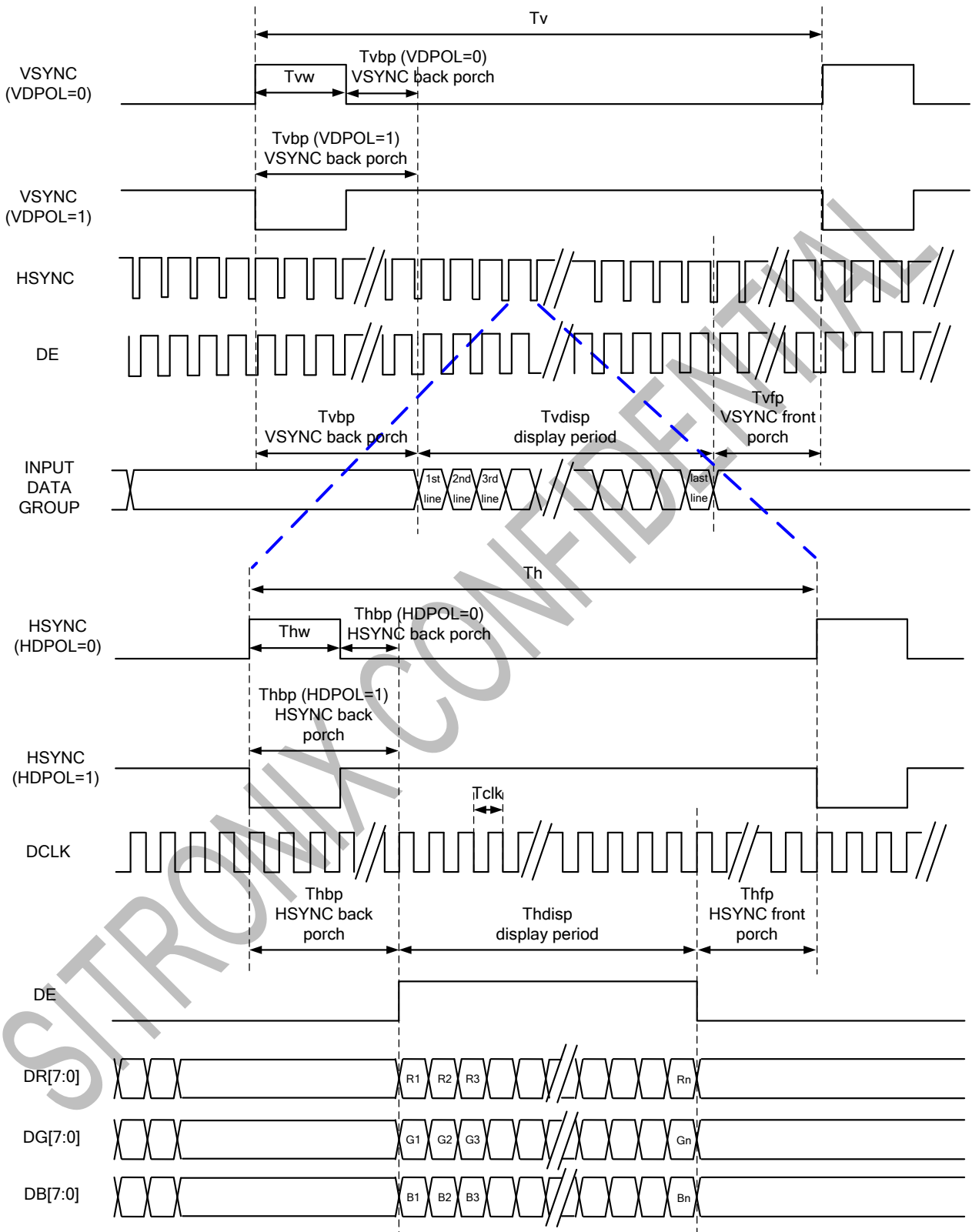

7.3.3 DE Mode

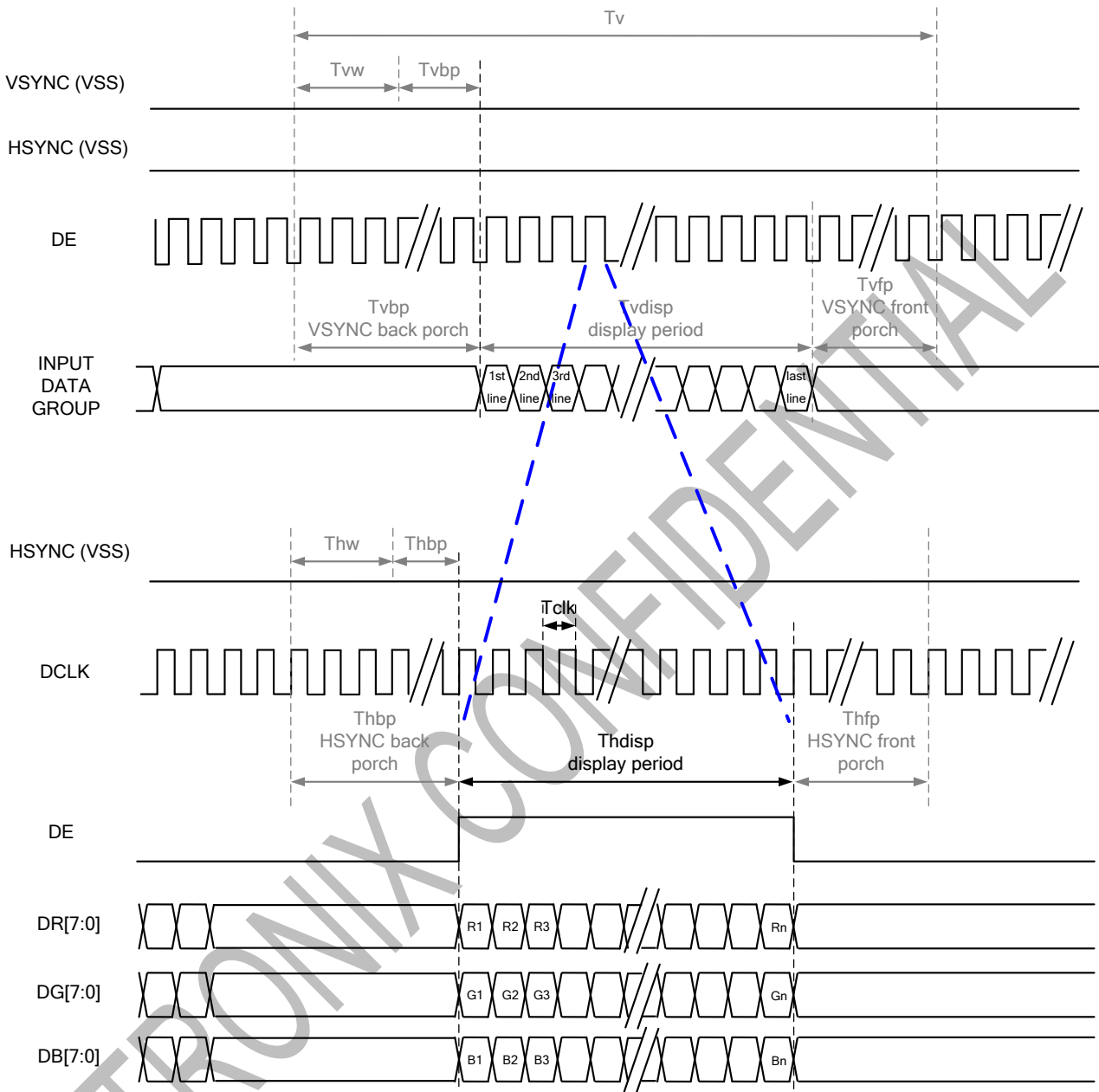

RGB Mode Selection Table	DCLK	HSYNC	VSYNC	DE
SYNC - DE Mode	Input	Input	Input	Input
SYNC Mode	Input	Input	Input	GND
DE Mode	Input	GND	GND	Input

Note: "Input" means these signals are driven by host side.

7.3.4 Parallel 24-bit RGB Input Timing Table

Parallel 24-bit RGB Input Timing (PVDD=VDD=VDDI= 3.3V, AGND= 0V, TA=25°C)

Parallel 24-bit RGB Input Timing Table							
Item	Symbol	Min.	Typ.	Max.	Unit	Note	
DCLK Frequency	Fclk	5	6	8	MHz		
DCLK Period	Tclk	125	167	200	ns		
HSYNC	Period Time	Th	325	371	438	DCLK	
	Display Period	Thdisp		320		DCLK	
	Back Porch	Thbp	3	43	43	DCLK	SYNC mode back porch control by H_BLANKING[7:0] setting Thbp= H_BLANKING[7:0]
	Front Porch	Thfp	2	8	75	DCLK	
	Pulse Width	Thw	2	4	43	DCLK	
VSYNC	Period Time	Tv	244	260	289	HSYNC	
	Display Period	Tvdisp		240		HSYNC	
	Back Porch	Tvbp	2	12	12	HSYNC	SYNC mode back porch control by V_BLANKING[7:0] setting Tvbp= V_BLANKING[7:0]
	Front Porch	Tvfp	2	8	37	HSYNC	
	Pulse Width	Tvw	2	4	12	HSYNC	

Note: It is necessary to keep Tvbp =12 and Thbp =43 in sync mode. DE mode is unnecessary to keep it.



7.3.5 Serial 8-bit RGB Input Timing Table

Serial 8-bit RGB Input Timing (PVDD=VDD=VDDI= 3.3V, AGND= 0V, TA=25°C)

Serial 8-bit RGB Input Timing Table							
Item	Symbol	Min.	Typ.	Max.	Unit	Remark	
DCLK Frequency	Fclk	15	18	21	MHz		
DCLK Period	Tclk	47	55	66	ns		
HSYNC	Period Time	Th	965	1011	1078	DCLK	
	Display Period	Thdisp		960		DCLK	
	Back Porch	Thbp	3	43	43	DCLK	SYNC mode back porch control by H_BLANKING[7:0] setting Thbp= H_BLANKING[7:0]
	Front Porch	Thfp	2	8	75	DCLK	
	Pulse Width	Thw	2	4	43	DCLK	
VSYNC	Period Time	Tv	244	260	289	HSYNC	
	Display Period	Tvdisp		240		HSYNC	
	Back Porch	Tvbp	2	12	12	HSYNC	SYNC mode back porch control by V_BLANKING[7:0] setting Tvbp= V_BLANKING[7:0]
	Front Porch	Tvfp	2	8	37	HSYNC	
	Pulse Width	Tvw	2	4	12	HSYNC	

Note: It is necessary to keep Tvbp =12 and Thbp =43 in sync mode. DE mode is unnecessary to keep it.

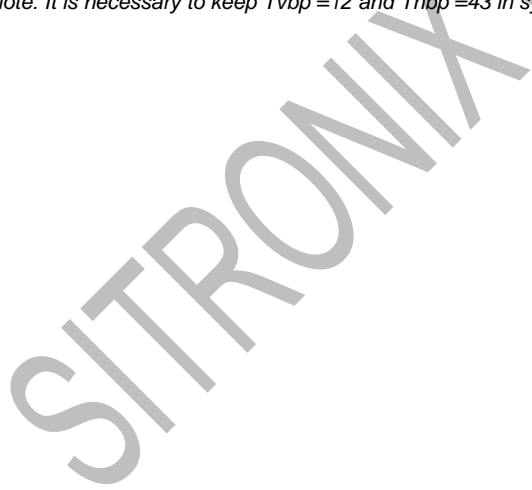

## 8. REGISTER LIST

### 8.1 Register Summary

COMMAND TABLE 1									
Address	D7	D6	D5	D4	D3	D2	D1	D0	Default
10h	0	0	0	0	GRB	0	0	DISP	08h
11h	CONTRAST[7:0]								40h
12h	0	SUB_CONTRAST_R[6:0]							40h
13h	0	SUB_CONTRAST_B[6:0]							40h
14h	BRIGHTNESS[7:0]								40h
15h	0	SUB_BRIGHTNESS_R[6:0]							40h
16h	0	SUB_BRIGHTNESS_B[6:0]							40h
17h	H_BLANKING[7:0]								2Bh
18h	V_BLANKING[7:0]								0Ch
19h	MVA_TN	VDIR	HDIR	SBGR	VDPOL	HDPOL	DEPOL	DCLKPOL	6Dh
1Ah	1	1	1	1	0	RGBSWAP	RGBMODE[1:0]		F7h
1Bh	0	0	0	0	1	AUTODL	0	0	0Ch
1Ch	0	0	PICSEC[1:0]		AUTOBIST	PICSEL [2:0]			38h
COMMAND TABLE 2									
Address	D7	D6	D5	D4	D3	D2	D1	D0	Default
40h	0	1	VRHP[5:0]						--
41h	0	VRHN[6:0]							--
43h	0	1	VCOM[5:0]						
44h	0	1	MODE[1:0]		AVCLS[1:0]		AVDDS[1:0]		--
45h	0	0	0	0	VGLSEL[1:0]		VGHSEL[1:0]		--
46h	T4T[1:0]		T3T[1:0]		T2T[1:0]		T1T[1:0]		--
47h	0	0	0	0	0	SOURCE_AP[2:0]			--
49h	0	NO[2:0]			0	Reserved[2:0]			--
4Ah	0	PRGB_GWIDTH[2:0]			0	SRGB_GWIDTH[2:0]			--

Note:

1. When GRB is "Low", all registers reset to default values.
2. Symbol "--" means this value is OTP setting according to parameters of system application, panel loading and display quality.
3. Do not use instructions not listed in these tables.

GAMMA COMMAND TABLE									
Address	D7	D6	D5	D4	D3	D2	D1	D0	Default
20h	0	0	0			VRF0P[4:0]			--
21h	0	0	0			VOS0P[4:0]			--
22h		PFP0[2:0]				PKP0[4:0]			--
23h		PFP1[2:0]				PKP1[4:0]			--
24h		PFP2[2:0]				PKP2[4:0]			--
25h		PFP3[2:0]				PKP3[4:0]			--
26h		PFP4[2:0]				PKP4[4:0]			--
27h		PFP5[2:0]				PKP5[4:0]			--
28h		PFP6[2:0]				PKP6[4:0]			--
29h	0	0	0			PKP7[4:0]			--
30h	0	0	0			VRF0N[4:0]			--
31h	0	0	0			VOS0N[4:0]			--
32h		PFN0[2:0]				PKN0[4:0]			--
33h		PFN1[2:0]				PKN1[4:0]			--
34h		PFN2[2:0]				PKN2[4:0]			--
35h		PFN3[2:0]				PKN3[4:0]			--
36h		PFN4[2:0]				PKN4[4:0]			--
37h		PFN5[2:0]				PKN5[4:0]			--
38h		PFN6[2:0]				PKN6[4:0]			--
39h	0	0	0			PKN7[4:0]			--

Note:

1. When GRB is "Low", all registers reset to default values.
2. Symbol "--" means this value is OTP setting according to parameters of system application, panel loading and display quality.
3. Do not use instructions not listed in these tables.

OTP COMMAND TABLE										
Address	D7	D6	D5	D4	D3	D2	D1	D0	Default	
01h	0	ID1[6:0]								7Fh
02h	0	ID2[6:0]								7Fh
03h	0	ID3[6:0]								7Fh
04h	0	I <sup>2</sup> CID[6:0]								78h
05h	0	VMF[6:0]								40h
60h	0	1	0	0	0	INTVPP	OTPEN	0	00h	
65h	OTPACK[7:0]									00h
66h	0	0	0	0	0	VMF OTP TIME[2:0]			03h	
67h	0	0	0	0	0	CMD2 OTP TIME[2:0]			03h	
68h	0	0	0	0	0	GAMMA OTP TIME[2:0]			03h	
69h	0	0	0	0	0	ID1 OTP TIME[2:0]			03h	
6Ah	0	0	0	0	0	ID2 OTP TIME[2:0]			03h	
6Bh	0	0	0	0	0	ID3 OTP TIME[2:0]			03h	
6Ch	0	0	0	0	0	I <sup>2</sup> CID OTP TIME[2:0]			03h	

Note:

1. When GRB is "Low", all registers reset to default values.
2. Symbol "--" means this value is OTP setting according to parameters of system application, panel loading and display quality.
3. Do not use instructions not listed in these tables.



8.2 Command Table1 Register Description

8.2.1 GRB 、 DISP CONTROL (10h)

Address	TYPE	D7	D6	D5	D4	D3	D2	D1	D0	Default
10h	R/W	0	0	0	0	GRB	0	0	DISP	08h

Designation	Description
GRB	Reset register setting GRB=0: reset all registers to default value GRB=1: normal operation
DISP	Standby (power saving) mode setting DISP=0: standby mode DISP=1: normal mode

8.2.2 CONTRAST (11h)

Address	TYPE	D7	D6	D5	D4	D3	D2	D1	D0	Default
11h	R/W	CONTRAST[7:0]								40h

Designation	Description
CONTRAST[7:0]	Set RGB contrast level, the range of gain is 0~3.984 CONTRAST=00h: contrast gain=0 CONTRAST=40h: contrast gain=1 CONTRAST=FFh: contrast gain=3.984

8.2.3 SUB\_CONTRAST\_R (12h)

Address	TYPE	D7	D6	D5	D4	D3	D2	D1	D0	Default
12h	R/W	0	SUB_CONTRAST_R[6:0]							40h

Designation	Description
SUB_CONTRAST_R[6:0]	Set red color sub-contrast level, the range of gain is 0.75~1.246 SUB_CONTRAST_R=00h: contrast gain=0.75 SUB_CONTRAST_R=40h: contrast gain=1 SUB_CONTRAST_R=7Fh: contrast gain=1.246

**8.2.4 SUB\_CONTRAST\_B (13h)**

Address	TYPE	D7	D6	D5	D4	D3	D2	D1	D0	Default
13h	R/W	0	SUB_CONTRAST_B[6:0]							40h

Designation	Description
SUB_CONTRAST_B[6:0]	Set blue color sub-contrast level, the range of gain is 0.75~1.246 SUB_CONTRAST_B=00h: contrast gain=0.75 SUB_CONTRAST_B=40h: contrast gain=1 SUB_CONTRAST_B=7Fh: contrast gain=1.246

**8.2.5 BRIGHTNESS (14h)**

Address	TYPE	D7	D6	D5	D4	D3	D2	D1	D0	Default
14h	R/W	BRIGHTNESS[7:0]								40h

Designation	Description
BRIGHTNESS[7:0]	Set RGB brightness level, the range of brightness is -64~+191 BRIGHTNESS=00h: -64 BRIGHTNESS=40h: 0 BRIGHTNESS=FFh: +191

**8.2.6 SUB-BRIGHTNESS\_R (15h)**

Address	TYPE	D7	D6	D5	D4	D3	D2	D1	D0	Default
15h	R/W	0	SUB_BRIGHTNESS_R[6:0]							40h

Designation	Description
SUB_BRIGHTNESS_R [6:0]	Set red color sub-brightness level, the range of brightness is -64~+63 SUB_BRIGHTNESS_R=00h: -64 SUB_BRIGHTNESS_R=40h: 0 SUB_BRIGHTNESS_R=7Fh: +63

**8.2.7 SUB-BRIGHTNESS\_B (16h)**

Address	TYPE	D7	D6	D5	D4	D3	D2	D1	D0	Default
16h	R/W	0	SUB_BRIGHTNESS_B[6:0]							40h

Designation	Description
SUB_BRIGHTNESS_B [6:0]	Set blue color sub-brightness level, the range of brightness is -64~+63 SUB_BRIGHTNESS_B=00h: -64 SUB_BRIGHTNESS_B=40h: 0 SUB_BRIGHTNESS_B=7Fh: +63

**8.2.8 H\_BLANKING (17h)**

Address	TYPE	D7	D6	D5	D4	D3	D2	D1	D0	Default
17h	R/W	H_BLANKING[7:0]								2Bh

Designation	Description
H_BLANKING[7:0]	The HSYNC back porch setting of RGB interface

**8.2.9 V\_BLANKING (18h)**

Address	TYPE	D7	D6	D5	D4	D3	D2	D1	D0	Default
18h	R/W	V_BLANKING[7:0]								0Ch

Designation	Description
V_BLANKING[7:0]	The VSYNC back porch setting of RGB interface

8.2.10 DISPLAY MODE SETTING (19h)

Address	TYPE	D7	D6	D5	D4	D3	D2	D1	D0	Default
19h	R/W	MVA_TN	VDIR	HDIR	SBGR	VDPOL	HDPOL	DEPOL	DCLKPOL	6Dh

Designation	Description
MVA_TN	MVA_TN=0: TN mode for panel display. MVA_TN=1: VA mode for panel display.
VDIR	Vertical scan direction setting VDIR= 0: from bottom to top, L(n)(first line) → L(n-1) →...→ L2 → L1(last line) VDIR= 1: from top to bottom, L1(first line) → L2 →...→ L(n-1) → L(n)(last line)
HDIR	Horizontal scan direction setting HDIR= 0: from right to left, Y(n)(first data) → Y(n-1) →...→ Y2 → Y1(last data) HDIR= 1: from left to right, Y1(first data) → Y2 →...→ Y(n-1) → Y(n)(last data)
SBGR	Data of red and blue exchange SBGR= 0: normal, DR[7:0]→DR[7:0] and DB[7:0]→DB[7:0] SBGR= 1: exchange, DR[7:0]→DB[7:0] and DB[7:0]→DR[7:0]
VDPOL	VSYNC polarity setting VDPOL= 0: positive polarity VDPOL= 1: negative polarity
HDPOL	HSYNC polarity setting HDPOL= 0: positive polarity HDPOL= 1: negative polarity
DEPOL	DE polarity setting DEPOL= 0: positive polarity DEPOL= 1: negative polarity
DCLKPOL	DCLK polarity setting DCLKPOL= 0: positive polarity DCLKPOL= 1: negative polarity

8.2.11 RGB INTERFACE MODE SETTING (1Ah)

Address	TYPE	D7	D6	D5	D4	D3	D2	D1	D0	Default
1Ah	R/W	1	1	1	1	0	RGBSWAP	RGBMODE[1:0]		F7h

Designation	Description																																																																																																				
RGBSWAP	Set data format sequence of RGB interface																																																																																																				
	<table border="1"> <thead> <tr> <th>Pin Name</th> <th>Internal Data</th> <th>RGBSWAP=0</th> <th>RGBSWAP=1</th> </tr> </thead> <tbody> <tr><td>DR0</td><td>r0'</td><td>r0'</td><td>r7'</td></tr> <tr><td>DR1</td><td>r1'</td><td>r1'</td><td>r6'</td></tr> <tr><td>DR2</td><td>r2'</td><td>r2'</td><td>r5'</td></tr> <tr><td>DR3</td><td>r3'</td><td>r3'</td><td>r4'</td></tr> <tr><td>DR4</td><td>r4'</td><td>r4'</td><td>r3'</td></tr> <tr><td>DR5</td><td>r5'</td><td>r5'</td><td>r2'</td></tr> <tr><td>DR6</td><td>r6'</td><td>r6'</td><td>r1'</td></tr> <tr><td>DR7</td><td>r7'</td><td>r7'</td><td>r0'</td></tr> <tr><td>DG0</td><td>g0'</td><td>g0'</td><td>g7'</td></tr> <tr><td>DG1</td><td>g1'</td><td>g1'</td><td>g6'</td></tr> <tr><td>DG2</td><td>g2'</td><td>g2'</td><td>g5'</td></tr> <tr><td>DG3</td><td>g3'</td><td>g3'</td><td>g4'</td></tr> <tr><td>DG4</td><td>g4'</td><td>g4'</td><td>g3'</td></tr> <tr><td>DG5</td><td>g5'</td><td>g5'</td><td>g2'</td></tr> <tr><td>DG6</td><td>g6'</td><td>g6'</td><td>g1'</td></tr> <tr><td>DG7</td><td>g7'</td><td>g7'</td><td>g0'</td></tr> <tr><td>DB0</td><td>b0'</td><td>b0'</td><td>b7'</td></tr> <tr><td>DB1</td><td>b1'</td><td>b1'</td><td>b6'</td></tr> <tr><td>DB2</td><td>b2'</td><td>b2'</td><td>b5'</td></tr> <tr><td>DB3</td><td>b3'</td><td>b3'</td><td>b4'</td></tr> <tr><td>DB4</td><td>b4'</td><td>b4'</td><td>b3'</td></tr> <tr><td>DB5</td><td>b5'</td><td>b5'</td><td>b2'</td></tr> <tr><td>DB6</td><td>b6'</td><td>b6'</td><td>b1'</td></tr> <tr><td>DB7</td><td>b7'</td><td>b7'</td><td>b0'</td></tr> </tbody> </table>	Pin Name	Internal Data	RGBSWAP=0	RGBSWAP=1	DR0	r0'	r0'	r7'	DR1	r1'	r1'	r6'	DR2	r2'	r2'	r5'	DR3	r3'	r3'	r4'	DR4	r4'	r4'	r3'	DR5	r5'	r5'	r2'	DR6	r6'	r6'	r1'	DR7	r7'	r7'	r0'	DG0	g0'	g0'	g7'	DG1	g1'	g1'	g6'	DG2	g2'	g2'	g5'	DG3	g3'	g3'	g4'	DG4	g4'	g4'	g3'	DG5	g5'	g5'	g2'	DG6	g6'	g6'	g1'	DG7	g7'	g7'	g0'	DB0	b0'	b0'	b7'	DB1	b1'	b1'	b6'	DB2	b2'	b2'	b5'	DB3	b3'	b3'	b4'	DB4	b4'	b4'	b3'	DB5	b5'	b5'	b2'	DB6	b6'	b6'	b1'	DB7	b7'	b7'	b0'
	Pin Name	Internal Data	RGBSWAP=0	RGBSWAP=1																																																																																																	
	DR0	r0'	r0'	r7'																																																																																																	
	DR1	r1'	r1'	r6'																																																																																																	
	DR2	r2'	r2'	r5'																																																																																																	
	DR3	r3'	r3'	r4'																																																																																																	
	DR4	r4'	r4'	r3'																																																																																																	
	DR5	r5'	r5'	r2'																																																																																																	
	DR6	r6'	r6'	r1'																																																																																																	
	DR7	r7'	r7'	r0'																																																																																																	
	DG0	g0'	g0'	g7'																																																																																																	
	DG1	g1'	g1'	g6'																																																																																																	
	DG2	g2'	g2'	g5'																																																																																																	
	DG3	g3'	g3'	g4'																																																																																																	
	DG4	g4'	g4'	g3'																																																																																																	
	DG5	g5'	g5'	g2'																																																																																																	
	DG6	g6'	g6'	g1'																																																																																																	
	DG7	g7'	g7'	g0'																																																																																																	
	DB0	b0'	b0'	b7'																																																																																																	
	DB1	b1'	b1'	b6'																																																																																																	
DB2	b2'	b2'	b5'																																																																																																		
DB3	b3'	b3'	b4'																																																																																																		
DB4	b4'	b4'	b3'																																																																																																		
DB5	b5'	b5'	b2'																																																																																																		
DB6	b6'	b6'	b1'																																																																																																		
DB7	b7'	b7'	b0'																																																																																																		
RGBMODE[1:0]	Set color format of RGB interface																																																																																																				
	<table border="1"> <thead> <tr> <th>RGBMODE [1:0]</th> <th>Color Format</th> </tr> </thead> <tbody> <tr><td>00</td><td>256-gray mono display</td></tr> <tr><td>01</td><td>64K</td></tr> <tr><td>10</td><td>262K</td></tr> <tr><td>11</td><td>16.7M</td></tr> </tbody> </table>	RGBMODE [1:0]	Color Format	00	256-gray mono display	01	64K	10	262K	11	16.7M																																																																																										
	RGBMODE [1:0]	Color Format																																																																																																			
	00	256-gray mono display																																																																																																			
	01	64K																																																																																																			
10	262K																																																																																																				
11	16.7M																																																																																																				

**8.2.12 ERROR REPORT AND OTP AUTO DOWNLOAD CONTROL (1Bh)**

Address	TYPE	D7	D6	D5	D4	D3	D2	D1	D0	Default
1Bh	R/W	0	0	0	0	1	AUTODL	0	0	0Ch

Designation	Description
AUTODL	Multi-OTP auto-refresh function control AUTODL= 0: disable auto-refresh function AUTODL= 1: enable auto-refresh function

**8.2.13 BIST FUNCTION SETTING (1Ch)**

Address	TYPE	D7	D6	D5	D4	D3	D2	D1	D0	Default
1Ch	R/W	0	0	PICSEC[1:0]		AUTOBIST	PICSEL[2:0]			38h

Designation	Description																		
PICSEC[1:0]	The time interval of test pattern in the BIST mode																		
	<table border="1"> <thead> <tr> <th>PICSEC[1:0]</th> <th>Time(sec)</th> </tr> </thead> <tbody> <tr> <td>00</td> <td>0.5</td> </tr> <tr> <td>01</td> <td>1</td> </tr> <tr> <td>10</td> <td>1.5</td> </tr> <tr> <td>11</td> <td>2</td> </tr> </tbody> </table>	PICSEC[1:0]	Time(sec)	00	0.5	01	1	10	1.5	11	2								
	PICSEC[1:0]	Time(sec)																	
	00	0.5																	
	01	1																	
10	1.5																		
11	2																		
AUTOBIST	Auto display pattern control in the BIST mode AUTOBIST=0: Disable auto display mode AUTOBIST=1: Enable auto display mode																		
	BIST pattern selection																		
PICSEL[2:0]	<table border="1"> <thead> <tr> <th>PICSEL [2:0]</th> <th>Display Pattern</th> </tr> </thead> <tbody> <tr> <td>000</td> <td>Black</td> </tr> <tr> <td>001</td> <td>White</td> </tr> <tr> <td>010</td> <td>Red</td> </tr> <tr> <td>011</td> <td>Green</td> </tr> <tr> <td>100</td> <td>Blue</td> </tr> <tr> <td>101</td> <td>Black</td> </tr> <tr> <td>110</td> <td>Black</td> </tr> <tr> <td>111</td> <td>Black</td> </tr> </tbody> </table>	PICSEL [2:0]	Display Pattern	000	Black	001	White	010	Red	011	Green	100	Blue	101	Black	110	Black	111	Black
	PICSEL [2:0]	Display Pattern																	
	000	Black																	
	001	White																	
	010	Red																	
	011	Green																	
	100	Blue																	
	101	Black																	
110	Black																		
111	Black																		

8.3 Command Table2 Register Description

8.3.1 GVDD SETTING (40h)

Address	TYPE	D7	D6	D5	D4	D3	D2	D1	D0	Default
40h	R/W	0	1	VRHP[5:0]						--

Designation	Description							
VRHP[5:0]	GVDD level setting							
	VRHP[5:0]	GVDD	VRHP[5:0]	GVDD	VRHP[5:0]	GVDD	VRHP[5:0]	GVDD
	000000	5.9680	010000	5.7120	100000	5.4560	110000	5.2000
	000001	5.9520	010001	5.6960	100001	5.4400	110001	5.1840
	000010	5.9360	010010	5.6800	100010	5.4240	110010	5.1680
	000011	5.9200	010011	5.6640	100011	5.4080	110011	5.1520
	000100	5.9040	010100	5.6480	100100	5.3920	110100	5.1360
	000101	5.8880	010101	5.6320	100101	5.3760	110101	5.1200
	000110	5.8720	010110	5.6160	100110	5.3600	110110	5.1040
	000111	5.8560	010111	5.6000	100111	5.3440	110111	5.0880
	001000	5.8400	011000	5.5840	101000	5.3280	111000	5.0720
	001001	5.8240	011001	5.5680	101001	5.3120	111001	5.0560
	001010	5.8080	011010	5.5520	101010	5.2960	111010	5.0400
	001011	5.7920	011011	5.5360	101011	5.2800	111011	5.0240
	001100	5.7760	011100	5.5200	101100	5.2640	111100	5.0080
	001101	5.7600	011101	5.5040	101101	5.2480	111101	4.9920
	001110	5.7440	011110	5.4880	101110	5.2320	111110	4.9760
001111	5.7280	011111	5.4720	101111	5.2160	111111	4.9600	

8.3.2 GVCL SETTING (41h)

Address	TYPE	D7	D6	D5	D4	D3	D2	D1	D0	Default
41h	R/W	0	VRHN[6:0]							--

Designation	Description							
VRHN[6:0]	GVCL level setting							
	VRHN[6:0]	GVCL	VRHN[6:0]	GVCL	VRHN[6:0]	GVCL	VRHN[6:0]	GVCL
	0100000	-4.4800	0111000	-4.0960	1010000	-3.7120	1101000	-3.3280
	0100001	-4.4640	0111001	-4.0800	1010001	-3.6960	1101001	-3.3120
	0100010	-4.448	0111010	-4.0640	1010010	-3.6800	1101010	-3.2960
	0100011	-4.4320	0111011	-4.0480	1010011	-3.6640	1101011	-3.2800
	0100100	-4.4160	0111100	-4.0320	1010100	-3.6480	1101100	-3.2640
	0100101	-4.4000	0111101	-4.0160	1010101	-3.6320	1101101	-3.2480
	0100110	-4.3840	0111110	-4.0000	1010110	-3.6160	1101110	-3.2320
	0100111	-4.3680	0111111	-3.9840	1010111	-3.6000	1101111	-3.2160
	0101000	-4.3520	1000000	-3.9680	1011000	-3.5840	1110000	-3.2000
	0101001	-4.3360	1000001	-3.9520	1011001	-3.5680	1110001	-3.1840
	0101010	-4.3200	1000010	-3.9360	1011010	-3.5520	1110010	-3.1680
	0101011	-4.3040	1000011	-3.9200	1011011	-3.5360	1110011	-3.1520
	0101100	-4.2880	1000100	-3.9040	1011100	-3.5200	1110100	-3.1360
	0101101	-4.2720	1000101	-3.8880	1011101	-3.5040	1110101	-3.1200
	0101110	-4.2560	1000110	-3.8720	1011110	-3.4880	1110110	-3.1040
	0101111	-4.2400	1000111	-3.8560	1011111	-3.4720	1110111	-3.0880
	0110000	-4.2240	1001000	-3.8400	1100000	-3.4560	1111000	-3.0720
	0110001	-4.2080	1001001	-3.8240	1100001	-3.4400	1111001	-3.0560
	0110010	-4.1920	1001010	-3.8080	1100010	-3.4240	1111010	-3.0400
	0110011	-4.1760	1001011	-3.7920	1100011	-3.4080	1111011	-3.0240
	0110100	-4.1600	1001100	-3.7760	1100100	-3.3920	1111100	-3.0080
	0110101	-4.1440	1001101	-3.7600	1100101	-3.3760	1111101	-2.9920
0110110	-4.1280	1001110	-3.7440	1100110	-3.3600	1111110	-2.9760	
0110111	-4.1120	1001111	-3.7280	1100111	-3.3440	1111111	-2.9600	



8.3.3 VCOM SETTING (43h)

Address	TYPE	D7	D6	D5	D4	D3	D2	D1	D0	Default
43h	R/W	0	1	VCOM[5:0]						--

Designation	Description							
VCOM[5:0]	VCOM level setting							
	VCOM[5:0]	VCOM	VCOM[5:0]	VCOM	VCOM[5:0]	VCOM	VCOM[5:0]	VCOM
	000000	-1.2160	010000	-0.9600	100000	-0.7040	110000	-0.4480
	000001	-1.2000	010001	-0.9440	100001	-0.6880	110001	-0.4320
	000010	-1.1840	010010	-0.9280	100010	-0.6720	110010	-0.4160
	000011	-1.1680	010011	-0.9120	100011	-0.6560	110011	-0.4000
	000100	-1.1520	010100	-0.8960	100100	-0.6400	110100	-0.3840
	000101	-1.1360	010101	-0.8800	100101	-0.6240	110101	-0.3680
	000110	-1.1200	010110	-0.8640	100110	-0.6080	110110	-0.3520
	000111	-1.1040	010111	-0.8480	100111	-0.5920	110111	-0.3360
	001000	-1.0880	011000	-0.8320	101000	-0.5760	111000	-0.3200
	001001	-1.0720	011001	-0.8160	101001	-0.5600	111001	-0.3040
	001010	-1.0560	011010	-0.8000	101010	-0.5440	111010	-0.2880
	001011	-1.0400	011011	-0.7840	101011	-0.5280	111011	-0.2720
	001100	-1.0240	011100	-0.7680	101100	-0.5120	111100	-0.2560
	001101	-1.0080	011101	-0.7520	101101	-0.4960	111101	-0.2400
	001110	-0.9920	011110	-0.7360	101110	-0.4800	111110	-0.2240
001111	-0.9760	011111	-0.7200	101111	-0.4640	111111	-0.2080	

8.3.4 AVDD, AVCL SETTING (44h)

Address	TYPE	D7	D6	D5	D4	D3	D2	D1	D0	Default
44h	R/W	0	1	MODE[1:0]		AVCLS[1:0]		AVDDS[1:0]		--

Designation	Description										
MODE[1:0]	AVDD booster mode setting										
	<table border="1"> <thead> <tr> <th>MODE[1:0]</th> <th>AVDD Booster Setting</th> </tr> </thead> <tbody> <tr> <td>00</td> <td>booster: x3</td> </tr> <tr> <td>01</td> <td>booster: x2</td> </tr> <tr> <td>10</td> <td>booster auto-detect, reference voltage: VDD:3.0V</td> </tr> <tr> <td>11</td> <td>booster auto-detect, reference voltage: VDD:3.1V</td> </tr> </tbody> </table>	MODE[1:0]	AVDD Booster Setting	00	booster: x3	01	booster: x2	10	booster auto-detect, reference voltage: VDD:3.0V	11	booster auto-detect, reference voltage: VDD:3.1V
	MODE[1:0]	AVDD Booster Setting									
	00	booster: x3									
	01	booster: x2									
10	booster auto-detect, reference voltage: VDD:3.0V										
11	booster auto-detect, reference voltage: VDD:3.1V										
AVCLS[1:0]	AVCL level setting										
	<table border="1"> <thead> <tr> <th>AVCLS[1:0]</th> <th>AVCL (V)</th> </tr> </thead> <tbody> <tr> <td>00</td> <td>-4.2</td> </tr> <tr> <td>01</td> <td>-4.6</td> </tr> <tr> <td>10</td> <td>Reserved</td> </tr> <tr> <td>11</td> <td>Reserved</td> </tr> </tbody> </table>	AVCLS[1:0]	AVCL (V)	00	-4.2	01	-4.6	10	Reserved	11	Reserved
	AVCLS[1:0]	AVCL (V)									
	00	-4.2									
	01	-4.6									
10	Reserved										
11	Reserved										
AVDDS[1:0]	AVDD level setting										
	<table border="1"> <thead> <tr> <th>AVDDS[1:0]</th> <th>AVDD (V)</th> </tr> </thead> <tbody> <tr> <td>00</td> <td>6.2</td> </tr> <tr> <td>01</td> <td>6.4</td> </tr> <tr> <td>10</td> <td>Reserved</td> </tr> <tr> <td>11</td> <td>Reserved</td> </tr> </tbody> </table>	AVDDS[1:0]	AVDD (V)	00	6.2	01	6.4	10	Reserved	11	Reserved
	AVDDS[1:0]	AVDD (V)									
	00	6.2									
	01	6.4									
10	Reserved										
11	Reserved										

**8.3.5 VGH, VGL SETTING (45h)**

Address	TYPE	D7	D6	D5	D4	D3	D2	D1	D0	Default
45h	R/W	0	0	0	0	VGLSEL[1:0]		VGHSEL[1:0]		--

Designation	Description										
VGLSEL[1:0]	VGL level setting										
	<table border="1"> <thead> <tr> <th>VGLSEL[1:0]</th> <th>VGL (V)</th> </tr> </thead> <tbody> <tr> <td>00</td> <td>-7</td> </tr> <tr> <td>01</td> <td>-8</td> </tr> <tr> <td>10</td> <td>-10</td> </tr> <tr> <td>11</td> <td>-11</td> </tr> </tbody> </table>	VGLSEL[1:0]	VGL (V)	00	-7	01	-8	10	-10	11	-11
	VGLSEL[1:0]	VGL (V)									
	00	-7									
	01	-8									
10	-10										
11	-11										
VGHSEL[1:0]	VGH level setting										
	<table border="1"> <thead> <tr> <th>VGHSEL[1:0]</th> <th>VGH (V)</th> </tr> </thead> <tbody> <tr> <td>00</td> <td>13</td> </tr> <tr> <td>01</td> <td>15</td> </tr> <tr> <td>10</td> <td>16</td> </tr> <tr> <td>11</td> <td>16.5</td> </tr> </tbody> </table>	VGHSEL[1:0]	VGH (V)	00	13	01	15	10	16	11	16.5
	VGHSEL[1:0]	VGH (V)									
	00	13									
	01	15									
10	16										
11	16.5										

SITRONIX CONFIDENTIAL

8.3.6 SOURCE EQUALIZE TIME SETTING (46h)

Address	TYPE	D7	D6	D5	D4	D3	D2	D1	D0	Default
46h	R/W	T4T[1:0]		T3T[1:0]		T2T[1:0]		T1T[1:0]		--

Designation	Description																																								
	<p>Source equalizing T4 timing setting</p> <table border="1"> <thead> <tr> <th>T4T[1:0]</th> <th>T4 (DCLK)</th> </tr> </thead> <tbody> <tr> <td>00</td> <td>4</td> </tr> <tr> <td>01</td> <td>8</td> </tr> <tr> <td>10</td> <td>17</td> </tr> <tr> <td>11</td> <td>26</td> </tr> </tbody> </table> <p>Source equalizing T3 timing setting</p> <table border="1"> <thead> <tr> <th>T3T[1:0]</th> <th>T3 (DCLK)</th> </tr> </thead> <tbody> <tr> <td>00</td> <td>0.5</td> </tr> <tr> <td>01</td> <td>8</td> </tr> <tr> <td>10</td> <td>17</td> </tr> <tr> <td>11</td> <td>26</td> </tr> </tbody> </table> <p>Source equalizing T2 timing setting</p> <table border="1"> <thead> <tr> <th>T2T[1:0]</th> <th>T2 (DCLK)</th> </tr> </thead> <tbody> <tr> <td>00</td> <td>0.5</td> </tr> <tr> <td>01</td> <td>8</td> </tr> <tr> <td>10</td> <td>17</td> </tr> <tr> <td>11</td> <td>26</td> </tr> </tbody> </table> <p>Source equalizing T1 timing setting</p> <table border="1"> <thead> <tr> <th>T1T[1:0]</th> <th>T1 (DCLK)</th> </tr> </thead> <tbody> <tr> <td>00</td> <td>OFF</td> </tr> <tr> <td>01</td> <td>8</td> </tr> <tr> <td>10</td> <td>17</td> </tr> <tr> <td>11</td> <td>26</td> </tr> </tbody> </table> <p>Note: The above source equalize timing table is only for 480RGB X 272 resolution application.</p>	T4T[1:0]	T4 (DCLK)	00	4	01	8	10	17	11	26	T3T[1:0]	T3 (DCLK)	00	0.5	01	8	10	17	11	26	T2T[1:0]	T2 (DCLK)	00	0.5	01	8	10	17	11	26	T1T[1:0]	T1 (DCLK)	00	OFF	01	8	10	17	11	26
T4T[1:0]	T4 (DCLK)																																								
00	4																																								
01	8																																								
10	17																																								
11	26																																								
T3T[1:0]	T3 (DCLK)																																								
00	0.5																																								
01	8																																								
10	17																																								
11	26																																								
T2T[1:0]	T2 (DCLK)																																								
00	0.5																																								
01	8																																								
10	17																																								
11	26																																								
T1T[1:0]	T1 (DCLK)																																								
00	OFF																																								
01	8																																								
10	17																																								
11	26																																								
T4T[1:0]																																									
T3T[1:0]																																									
T2T[1:0]																																									
T1T[1:0]																																									

8.3.7 SOURCE OP-AMP POWER SETTING (47h)

Address	TYPE	D7	D6	D5	D4	D3	D2	D1	D0	Default
47h	R/W	0	0	0	0	0	SOURCE_AP[2:0]			--

Designation	Description																		
SOURCE_AP[2:0]	Source driving ability setting. When value is higher, the source output current will increase.																		
	<table border="1"> <thead> <tr> <th>SOURCE_AP[2:0]</th> <th>Source Power</th> </tr> </thead> <tbody> <tr> <td>000</td> <td>Level 1 (lowest)</td> </tr> <tr> <td>001</td> <td>Level 2 (minimal)</td> </tr> <tr> <td>010</td> <td>Level 3 (minimal to medium)</td> </tr> <tr> <td>011</td> <td>Level 4 (medium)</td> </tr> <tr> <td>100</td> <td>Level 5 (medium to large)</td> </tr> <tr> <td>101</td> <td>Level 6 (large)</td> </tr> <tr> <td>110</td> <td>Level 7 (large to highest)</td> </tr> <tr> <td>111</td> <td>Level 8 (highest)</td> </tr> </tbody> </table>	SOURCE_AP[2:0]	Source Power	000	Level 1 (lowest)	001	Level 2 (minimal)	010	Level 3 (minimal to medium)	011	Level 4 (medium)	100	Level 5 (medium to large)	101	Level 6 (large)	110	Level 7 (large to highest)	111	Level 8 (highest)
	SOURCE_AP[2:0]	Source Power																	
	000	Level 1 (lowest)																	
	001	Level 2 (minimal)																	
	010	Level 3 (minimal to medium)																	
	011	Level 4 (medium)																	
	100	Level 5 (medium to large)																	
	101	Level 6 (large)																	
	110	Level 7 (large to highest)																	
111	Level 8 (highest)																		
<i>Note: The setting value needs to be adjusted according to the display performance.</i>																			

8.3.8 GATE TIMING SETTING 1 (49h)

Address	TYPE	D7	D6	D5	D4	D3	D2	D1	D0	Default
49h	R/W	0	NO[2:0]			0	Reserved[2:0]			--

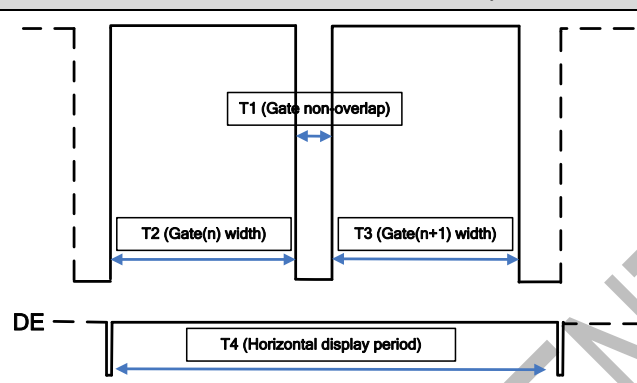
Designation	Description																		
NO[2:0]	 <p>Gate (n) and Gate (n+1) non-overlap timing setting</p> <table border="1"> <thead> <tr> <th>NO[2:0]</th> <th>Gate non-overlap (DCLK)</th> </tr> </thead> <tbody> <tr> <td>000</td> <td>9</td> </tr> <tr> <td>001</td> <td>19</td> </tr> <tr> <td>010</td> <td>38</td> </tr> <tr> <td>011</td> <td>57</td> </tr> <tr> <td>100</td> <td>76</td> </tr> <tr> <td>101</td> <td>96</td> </tr> <tr> <td>110</td> <td>115</td> </tr> <tr> <td>111</td> <td>134</td> </tr> </tbody> </table>	NO[2:0]	Gate non-overlap (DCLK)	000	9	001	19	010	38	011	57	100	76	101	96	110	115	111	134
NO[2:0]	Gate non-overlap (DCLK)																		
000	9																		
001	19																		
010	38																		
011	57																		
100	76																		
101	96																		
110	115																		
111	134																		

8.3.9 GATE TIMING SETTING 2 (4Ah)

Address	TYPE	D7	D6	D5	D4	D3	D2	D1	D0	Default
4Ah	R/W	0		PRGB_GWIDTH[2:0]		0		SRGB_GWIDTH[2:0]		--

Designation	Description																																																						
PRGB_GWIDTH[2:0] SRGB_GWIDTH[2:0]	<p>Set gate pulse width of parallel RGB interface.</p> <table border="1"> <thead> <tr> <th>PRGB_GWIDTH[2:0]</th> <th>T2 Gate (n) width (DCLK)</th> <th>T3 Gate (n+1) width (DCLK)</th> </tr> </thead> <tbody> <tr><td>000</td><td>GT1</td><td>GT2</td></tr> <tr><td>001</td><td>GT1 + 19</td><td>GT2 - 19</td></tr> <tr><td>010</td><td>GT1 + 38</td><td>GT2 - 38</td></tr> <tr><td>011</td><td>GT1 + 57</td><td>GT2 - 57</td></tr> <tr><td>100</td><td>GT1 + 76</td><td>GT2 - 76</td></tr> <tr><td>101</td><td>GT1 + 96</td><td>GT2 - 96</td></tr> <tr><td>110</td><td>GT1 + 115</td><td>GT2 - 115</td></tr> <tr><td>111</td><td>GT1 + 134</td><td>GT2 - 134</td></tr> </tbody> </table> <p>Set gate pulse width of serial RGB interface.</p> <table border="1"> <thead> <tr> <th>SRGB_GWIDTH[2:0]</th> <th>T2 Gate (n) width (DCLK)</th> <th>T3 Gate (n+1) width (DCLK)</th> </tr> </thead> <tbody> <tr><td>000</td><td>GT1</td><td>GT2</td></tr> <tr><td>001</td><td>GT1 + 19</td><td>GT2 - 19</td></tr> <tr><td>010</td><td>GT1 + 38</td><td>GT2 - 38</td></tr> <tr><td>011</td><td>GT1 + 57</td><td>GT2 - 57</td></tr> <tr><td>100</td><td>GT1 + 76</td><td>GT2 - 76</td></tr> <tr><td>101</td><td>GT1 + 96</td><td>GT2 - 96</td></tr> <tr><td>110</td><td>GT1 + 115</td><td>GT2 - 115</td></tr> <tr><td>111</td><td>GT1 + 134</td><td>GT2 - 134</td></tr> </tbody> </table>	PRGB_GWIDTH[2:0]	T2 Gate (n) width (DCLK)	T3 Gate (n+1) width (DCLK)	000	GT1	GT2	001	GT1 + 19	GT2 - 19	010	GT1 + 38	GT2 - 38	011	GT1 + 57	GT2 - 57	100	GT1 + 76	GT2 - 76	101	GT1 + 96	GT2 - 96	110	GT1 + 115	GT2 - 115	111	GT1 + 134	GT2 - 134	SRGB_GWIDTH[2:0]	T2 Gate (n) width (DCLK)	T3 Gate (n+1) width (DCLK)	000	GT1	GT2	001	GT1 + 19	GT2 - 19	010	GT1 + 38	GT2 - 38	011	GT1 + 57	GT2 - 57	100	GT1 + 76	GT2 - 76	101	GT1 + 96	GT2 - 96	110	GT1 + 115	GT2 - 115	111	GT1 + 134	GT2 - 134
	PRGB_GWIDTH[2:0]	T2 Gate (n) width (DCLK)	T3 Gate (n+1) width (DCLK)																																																				
	000	GT1	GT2																																																				
	001	GT1 + 19	GT2 - 19																																																				
	010	GT1 + 38	GT2 - 38																																																				
	011	GT1 + 57	GT2 - 57																																																				
	100	GT1 + 76	GT2 - 76																																																				
	101	GT1 + 96	GT2 - 96																																																				
	110	GT1 + 115	GT2 - 115																																																				
	111	GT1 + 134	GT2 - 134																																																				
SRGB_GWIDTH[2:0]	T2 Gate (n) width (DCLK)	T3 Gate (n+1) width (DCLK)																																																					
000	GT1	GT2																																																					
001	GT1 + 19	GT2 - 19																																																					
010	GT1 + 38	GT2 - 38																																																					
011	GT1 + 57	GT2 - 57																																																					
100	GT1 + 76	GT2 - 76																																																					
101	GT1 + 96	GT2 - 96																																																					
110	GT1 + 115	GT2 - 115																																																					
111	GT1 + 134	GT2 - 134																																																					

8.4 Gamma Table Register Description

8.4.1 GAMMA SETTING (20h~29h, 30h~39h)

Address	TYPE	D7	D6	D5	D4	D3	D2	D1	D0	Default
20h	R/W	0	0	0	VRF0P[4:0]					--
21h	R/W	0	0	0	VOS0P[4:0]					--
22h	R/W	PFP0[2:0]			PKP0[4:0]					--
23h	R/W	PFP1[2:0]			PKP1[4:0]					--
24h	R/W	PFP2[2:0]			PKP2[4:0]					--
25h	R/W	PFP3[2:0]			PKP3[4:0]					--
26h	R/W	PFP4[2:0]			PKP4[4:0]					--
27h	R/W	PFP5[2:0]			PKP5[4:0]					--
28h	R/W	PFP6[2:0]			PKP6[4:0]					--
29h	R/W	0	0	0	PKP7[4:0]					--
30h	R/W	0	0	0	VRF0N[4:0]					--
31h	R/W	0	0	0	VOS0N[4:0]					--
32h	R/W	PFN0[2:0]			PKN0[4:0]					--
33h	R/W	PFN1[2:0]			PKN1[4:0]					--
34h	R/W	PFN2[2:0]			PKN2[4:0]					--
35h	R/W	PFN3[2:0]			PKN3[4:0]					--
36h	R/W	PFN4[2:0]			PKN4[4:0]					--
37h	R/W	PFN5[2:0]			PKN5[4:0]					--
38h	R/W	PFN6[2:0]			PKN6[4:0]					--
39h	R/W	0	0	0	PKN7[4:0]					--

Designation	Description
PKP0[4:0]	V16 gamma selection
PKN0[4:0]	
PKP1[4:0]	V32 gamma selection
PKN1[4:0]	
PKP2[4:0]	V48 gamma selection
PKN2[4:0]	
PKP3[4:0]	V80 gamma selection
PKN3[4:0]	
PKP4[4:0]	V176 gamma selection
PKPN4[4:0]	
PKP5[4:0]	V208 gamma selection
PKN5[4:0]	



PKP6[4:0]	V224 gamma selection
PKN6[4:0]	
PKP7[4:0]	V240 gamma selection
PKN7[4:0]	
VRFOP[4:0]	V8 gamma selection
VRFON[4:0]	
VOS0P[4:0]	V248 gamma selection
VOS0N [4:0]	
PFP0[2:0]	V12 gamma selection
PFN0[2:0]	
PFP1[2:0]	V64 gamma selection
PFN1[2:0]	
PFP2[2:0]	V104 gamma selection
PFN2[2:0]	
PFP3[2:0]	V128 gamma selection
PFN3[2:0]	
PFP4[2:0]	V152 gamma selection
PFN4[2:0]	
PFP5[2:0]	V192 gamma selection
PFN5[2:0]	
PFP6[2:0]	V244 gamma selection
PFN6[2:0]	

SITRONIX CONFIDENTIAL

## 8.5 OTP Table Register Description

### 8.5.1 ID1 SETTING (01h)

Address	TYPE	D7	D6	D5	D4	D3	D2	D1	D0	Default	
01h	R/W	0	ID1[6:0]								7Fh

Designation	Description
ID1[6:0]	Built-in OTP for ID1 setting. The OTP supports 3 times programming

### 8.5.2 ID2 SETTING (02h)

Address	TYPE	D7	D6	D5	D4	D3	D2	D1	D0	Default	
02h	R/W	0	ID2[6:0]								7Fh

Designation	Description
ID2[6:0]	Built-in OTP for ID2 setting. The OTP supports 3 times programming

### 8.5.3 ID3 SETTING (03h)

Address	TYPE	D7	D6	D5	D4	D3	D2	D1	D0	Default	
03h	R/W	0	ID3[6:0]								7Fh

Designation	Description
ID3[6:0]	Built-in OTP for ID3 setting. The OTP supports 3 times programming

### 8.5.4 2C ID CODE SETTING (04h)

Address	TYPE	D7	D6	D5	D4	D3	D2	D1	D0	Default	
04h	R/W	0	I <sup>2</sup> CID[6:0]								78h

Designation	Description
I <sup>2</sup> CID[6:0]	Built-in OTP for I <sup>2</sup> C interface ID setting. The OTP supports 3 times programming

8.5.5 VCOM OFFSET SETTING (05h)

Address	TYPE	D7	D6	D5	D4	D3	D2	D1	D0	Default
05h	R/W	0	VMF[6:0]							40h

Designation	Description																																							
VMF[6:0]	VCOM offset setting <table border="1"> <thead> <tr> <th>VMF[6]</th> <th>VMF[5:0]</th> <th>VCOM</th> </tr> </thead> <tbody> <tr> <td>0</td> <td>000000</td> <td>VCOM[5:0]-64d</td> </tr> <tr> <td>0</td> <td>000001</td> <td>VCOM[5:0]-63d</td> </tr> <tr> <td>0</td> <td>000010</td> <td>VCOM[5:0]-62d</td> </tr> <tr> <td>0</td> <td> </td> <td> </td> </tr> <tr> <td>0</td> <td>111110</td> <td>VCOM[5:0]-2d</td> </tr> <tr> <td>0</td> <td>111111</td> <td>VCOM[5:0]-1d</td> </tr> <tr> <td>1</td> <td>000000</td> <td>VCOM[5:0]</td> </tr> <tr> <td>1</td> <td>000001</td> <td>VCOM[5:0]+1d</td> </tr> <tr> <td>1</td> <td>000010</td> <td>VCOM[5:0]+2d</td> </tr> <tr> <td>1</td> <td> </td> <td> </td> </tr> <tr> <td>1</td> <td>111110</td> <td>VCOM[5:0]+62d</td> </tr> <tr> <td>1</td> <td>111111</td> <td>VCOM[5:0]+63d</td> </tr> </tbody> </table>	VMF[6]	VMF[5:0]	VCOM	0	000000	VCOM[5:0]-64d	0	000001	VCOM[5:0]-63d	0	000010	VCOM[5:0]-62d	0			0	111110	VCOM[5:0]-2d	0	111111	VCOM[5:0]-1d	1	000000	VCOM[5:0]	1	000001	VCOM[5:0]+1d	1	000010	VCOM[5:0]+2d	1			1	111110	VCOM[5:0]+62d	1	111111	VCOM[5:0]+63d
	VMF[6]	VMF[5:0]	VCOM																																					
	0	000000	VCOM[5:0]-64d																																					
	0	000001	VCOM[5:0]-63d																																					
	0	000010	VCOM[5:0]-62d																																					
	0																																							
	0	111110	VCOM[5:0]-2d																																					
	0	111111	VCOM[5:0]-1d																																					
	1	000000	VCOM[5:0]																																					
	1	000001	VCOM[5:0]+1d																																					
	1	000010	VCOM[5:0]+2d																																					
	1																																							
	1	111110	VCOM[5:0]+62d																																					
1	111111	VCOM[5:0]+63d																																						
<i>Note: d=16mV</i>																																								

8.5.6 OTP FUNCTION CONTROL (60h)

Address	TYPE	D7	D6	D5	D4	D3	D2	D1	D0	Default
60h	R/W	0	0	0	0	1	INTVPP	OTPEN	1	09h

Designation	Description
INTVPP	Internal VPP function control INTVPP = 0: disable internal VPP function INTVPP = 1: enable internal VPP function
OTPEN	OTP function control OTPEN = 0: disable OTP function OTPEN = 1: enable OTP function

**8.5.7 OTP ACKNOWLEDGEMENT CONTROL (65h)**

Address	TYPE	D7	D6	D5	D4	D3	D2	D1	D0	Default
65h	R/W	OTPACK[7:0]								00h

Designation	Description																
OTPACK[7:0]	OTP active control																
	<table border="1"> <thead> <tr> <th>OTPACK[7:0]</th> <th>Description</th> </tr> </thead> <tbody> <tr> <td>31h</td> <td>ID1 program</td> </tr> <tr> <td>32h</td> <td>ID2 program</td> </tr> <tr> <td>33h</td> <td>ID3 program</td> </tr> <tr> <td>34h</td> <td>I<sup>2</sup>C I/F ID program</td> </tr> <tr> <td>3Ah</td> <td>VCOM offset program</td> </tr> <tr> <td>4Bh</td> <td>Command 2 program</td> </tr> <tr> <td>5Ch</td> <td>Gamma program</td> </tr> </tbody> </table>	OTPACK[7:0]	Description	31h	ID1 program	32h	ID2 program	33h	ID3 program	34h	I <sup>2</sup> C I/F ID program	3Ah	VCOM offset program	4Bh	Command 2 program	5Ch	Gamma program
	OTPACK[7:0]	Description															
	31h	ID1 program															
	32h	ID2 program															
	33h	ID3 program															
	34h	I <sup>2</sup> C I/F ID program															
	3Ah	VCOM offset program															
	4Bh	Command 2 program															
5Ch	Gamma program																

**8.5.8 VCOM OFFSET OTP PROGRAM TIMES (66h)**

Address	TYPE	D7	D6	D5	D4	D3	D2	D1	D0	Default
66h	R	0	0	0	0	0	VMF OTP TIME[2:0]			03h

Designation	Description
VMF OTP TIME[2:0]	Read VCOM offset programmable times

**8.5.9 COMMAND 2 PROGRAM TIMES (67h)**

Address	TYPE	D7	D6	D5	D4	D3	D2	D1	D0	Default
67h	R	0	0	0	0	0	CMD2 OTP TIME[2:0]			03h

Designation	Description
CMD2 OTP TIME[2:0]	Read COMMAND 2 programmable times

**8.5.10 GAMMA OTP PROGRAM TIMES (68h)**

Address	TYPE	D7	D6	D5	D4	D3	D2	D1	D0	Default
68h	R	0	0	0	0	0	GAMMA OTP TIME[2:0]			03h

Designation	Description
GAMMA OTP TIME[2:0]	Read GAMMA programmable times

**8.5.11 ID1 OTP PROGRAM TIMES (69h)**

Address	TYPE	D7	D6	D5	D4	D3	D2	D1	D0	Default
69h	R	0	0	0	0	0	ID1 OTP TIME[2:0]			03h

Designation	Description
ID1 OTP TIME[2:0]	Read ID1 programmable times

**8.5.12 ID2 OTP PROGRAM TIMES (6Ah)**

Address	TYPE	D7	D6	D5	D4	D3	D2	D1	D0	Default
6Ah	R	0	0	0	0	0	ID2 OTP TIME[2:0]			03h

Designation	Description
ID2 OTP TIME[2:0]	Read ID2 programmable times

**8.5.13 ID3 OTP PROGRAM TIMES (6Bh)**

Address	TYPE	D7	D6	D5	D4	D3	D2	D1	D0	Default
6Bh	R	0	0	0	0	0	ID3 OTP TIME[2:0]			03h

Designation	Description
ID3 OTP TIME[2:0]	Read ID2 programmable times

**8.5.14 I<sup>2</sup>C ID OTP PROGRAM TIMES (6Ch)**

Address	TYPE	D7	D6	D5	D4	D3	D2	D1	D0	Default
6Ch	R	0	0	0	0	0	I <sup>2</sup> CID OTP TIME[2:0]			03h

Designation	Description
I <sup>2</sup> CID OTPTIME[2:0]	Read I <sup>2</sup> CID programmable times

## 9. ELECTRICAL SPECIFICATIONS

### 9.1 Absolute Maximum Ratings

Item	Symbol	Rating	Unit
Power Supply Voltage	VDD	- 0.3 ~ +4.0	V
IO Supply Voltage	VDDI	- 0.3 ~ +4.0	V
Charge Pump Supply Voltage	PVDD	- 0.3 ~ +4.0	V
Logic Input Voltage Range	VIN	-0.3 ~ VDDI + 0.3	V
Logic Output Voltage Range	VOUT	-0.3 ~ VDDI + 0.3	V
Operating Temperature Range	TOPR	-30 ~ +85	°C
Storage Temperature Range	TSTG	-40 ~ +125	°C

Note:

1. That the stress exceeds the Limiting Value listed above it may cause the driver IC permanent damage. These values are for stress only. IC should be operated under the DC/AC Characteristic conditions for normal operation. If these conditions are not met, IC operation may be error and the reliability may be deteriorated.
2. Parameters are valid over operating temperature range unless otherwise specified. All voltages are with respect to VSS unless otherwise noted.
3. VIN should be less than or equal to 3.6V. ( $V_{IN} \leq 3.6V$ )

**9.2 DC Characteristics**

DC Electrical Characteristics (PVDD=VDD=VDDI= 3.3V, AGND= 0V, TA=25°C, Bare Chip)

**Recommended Operating Range**

Item	Symbol	Min.	Typ.	Max.	Unit	Conditions
Supply Voltage	VDD	3.0	3.3	3.6	V	
IO Supply Voltage	VDDI	3.0	-	3.6	V	
Charge Pump Supply Voltage	PVDD	3.0	3.3	3.6	V	

**DC Characteristics for Digital Circuit**

Item	Symbol	Min.	Typ.	Max.	Unit	Conditions
Logic-High Input Voltage	Vih	0.7VDDI	-	VDDI	V	
Logic-Low Input Voltage	Vil	DGND	-	0.3VDDI	V	
Logic-High Output Voltage	Voh	VDDI-0.4	-	VDDI	V	
Logic-Low Output Voltage	Vol	DGND	-	DGND+0.4	V	

**DC Characteristics for Analog Circuit**

Item	Symbol	Min.	Typ.	Max.	Unit	Conditions
Positive High-Voltage Power	VGH	13	15	16.5	V	No Load@ FR=60Hz
Negative High-Voltage Power	VGL	-7	-10	-11	V	
Output Voltage Deviation	Vod	-	±35	±45	mV	
Standby Current	Isc	-		50	uA	
Operation Current	Ioc	-	20		mA	

9.3 AC Characteristics

AC Electrical Characteristics (PVDD=VDD=VDDI= 3.3V, AGND= 0V, TA=25°C, Bare Chip)

9.3.1 System Operation AC Characteristics

Item	Symbol	Min.	Typ.	Max.	Unit	Conditions
VDD Power Source Slew Time	TPOR	-	-	20	ms	From 0V to 99% VDD
GRB Pulse Width	tRSTW	10	50	-	us	R=10Kohm, C=1uF
SD Output Stable Time	Tst	-	-	12	us	Output settled within +20mV Loading = 6.8k+28.2pF.
GD Output Rise and Fall Time	Tgst	-	-	6	us	Output settled (5%~95%), Loading = 4.7k+29.8pF

9.3.2 System Bus Timing for I<sup>2</sup>C Interface

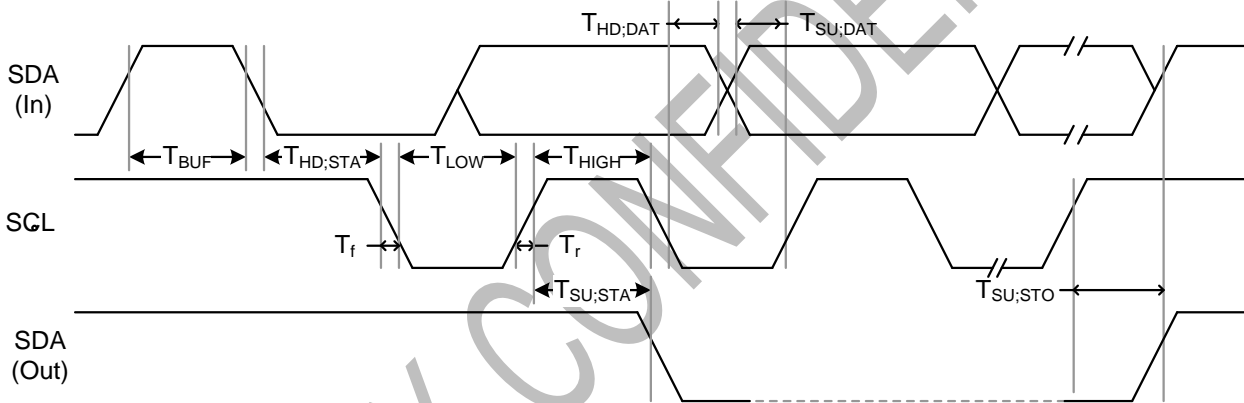

Item	Symbol	Min.	Typ.	Max.	Unit	Conditions
SCL Clock Frequency	FSCL	-	-	400	KHz	
SCL Clock Low Period	TLOW	1300	-	-	ns	
SCL Clock High Period	THIGH	600	-	-	ns	
Signal Rise Time	Tr	20+0.1Cb	-	300	ns	
Signal Fall Time	Tf	20+0.1Cb	-	300	ns	
Start Condition Setup Time	TSU;STA	600	-	-	ns	
Start Condition Hold Time	THD;STA	600	-	-	ns	
Data Setup Time	TSU;DAT	100	-	-	ns	
Data Hold Time	THD;DAT	0	-	900	ns	
Setup Time for STOP Condition	TSU;STO	600	-	-	ns	
Bus Free Time Between a STOP and START	TBUF	100	-	-	ns	
Capacitive load represented by each bus line		Cb		400	pF	
Tolerable Spike Width on Bus	TSW	-	-	50	ns	



9.3.3 System Bus Timing for 3-Wire SPI Interface

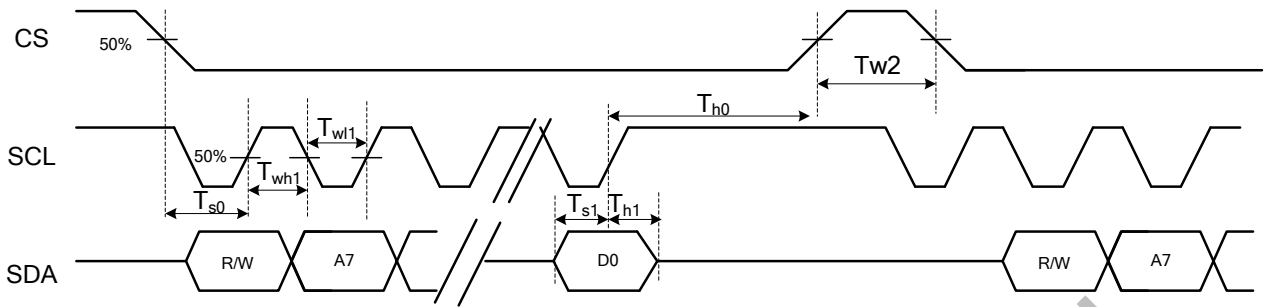

Item	Symbol	Min.	Typ.	Max.	Unit	Conditions
CS Input Setup Time	$T_{s0}$	50	-	-	ns	
Serial Data Input Setup Time	$T_{s1}$	50	-	-	ns	
CS Input Hold Time	$T_{h0}$	50	-	-	ns	
Serial Data Input Hold Time	$T_{h1}$	50	-	-	ns	
SCL Write Pulse High Width	$T_{wh1}$	50	-	-	ns	
SCL Write Pulse Low Width	$T_{wl1}$	50	-	-	ns	
SCL Read Pulse High Width	$T_{rh1}$	300			ns	
SCL Read Pulse Low Width	$T_{rl1}$	300			ns	
CS Pulse High Width	$T_{w2}$	400	-	-	ns	

9.3.4 System Bus Timing for RGB Interface

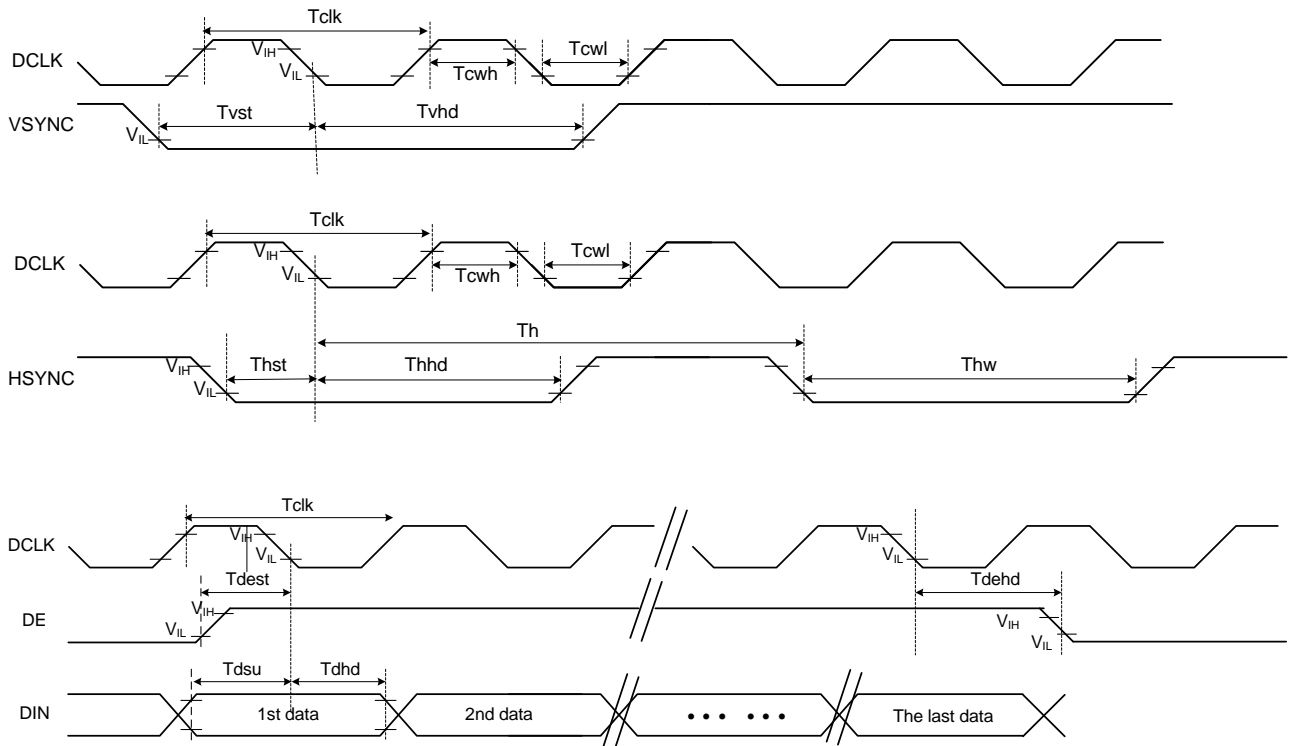

Item	Symbol	Min.	Typ.	Max.	Unit	Conditions
CLK Pulse Duty	Tclk	40	50	60	%	
HSYNC Width	Thw	2	-	-	DCLK	
HSYNC Period	Th	55	60	65	us	
VSYNC Setup Time	Tvst	12	-	-	ns	
VSYNC Hold Time	Tvhd	12	-	-	ns	
HSYNC Setup Time	Thst	12	-	-	ns	
HSYNC Hold Time	Thhd	12	-	-	ns	
Data Setup Time	Tdsu	12	-	-	ns	
Data Hold Time	Tdhd	12	-	-	ns	
DE Setup Time	Tdest	12	-	-	ns	
DE Hold Time	Tdehd	12	-	-	ns	

10. APPLICATION CIRCUIT

10.1 External Component of Power Circuit

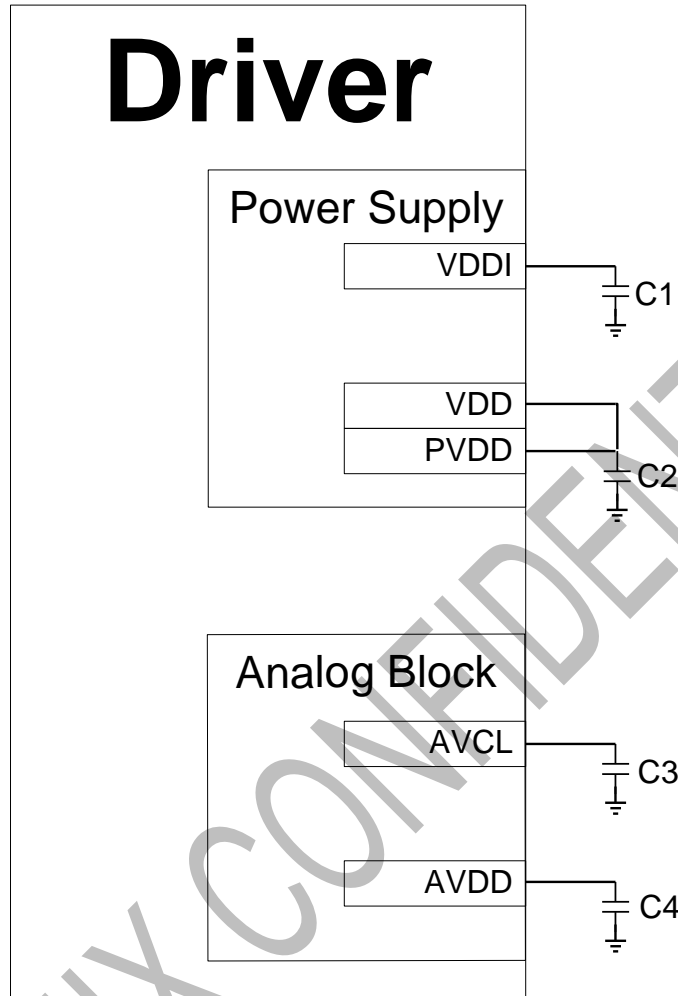

Symbol	Capacitance (uf)	Voltage Proof (V)	Remarks	Note
C1	1	6	X7R	Default NC
C2	1	6	X7R	Default NC
C3	1	10	X7R	Default NC
C4	1	10	X7R	Default NC

Note: Default NC, The components would be needed depend on the system power, panel loading and display quality

10.2 Parallel 24-bit RGB with 3-wire SPI

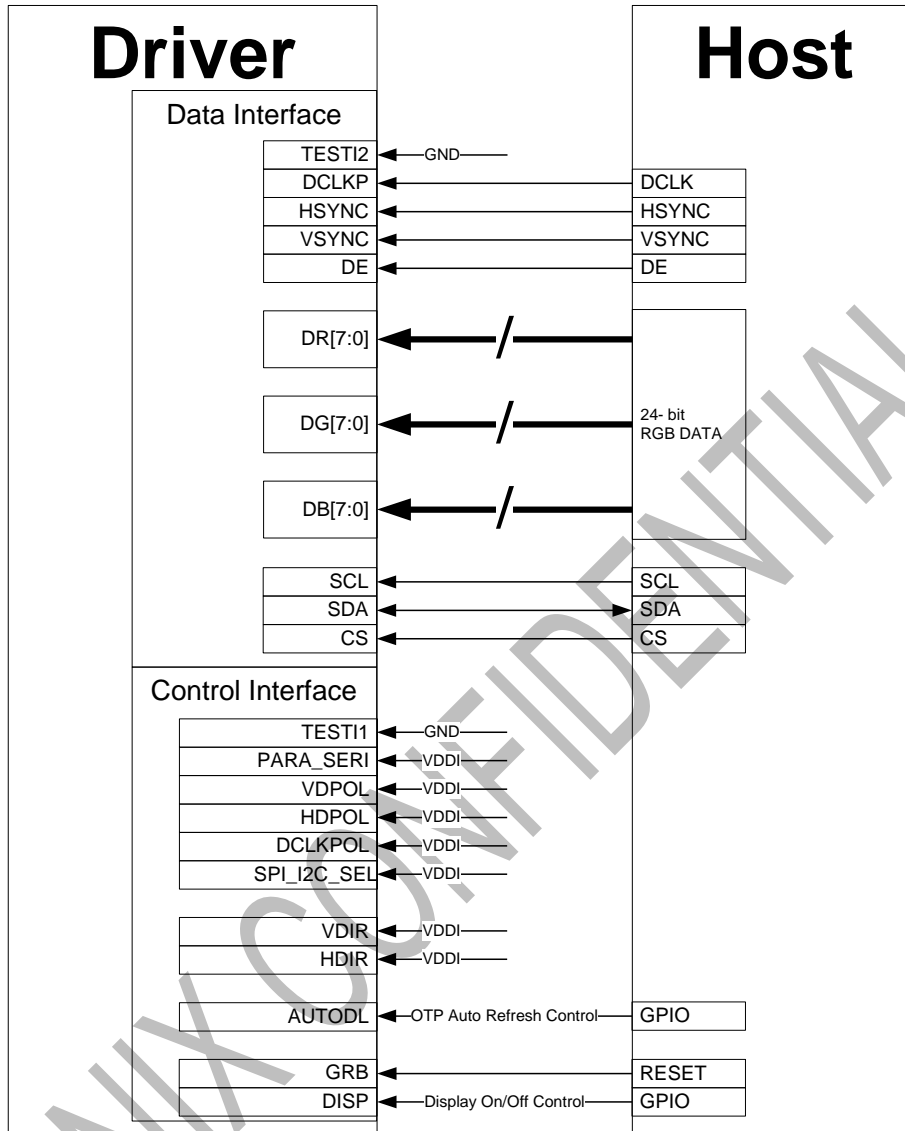

Pin Connection	Description
TESTI[2:1]	Reserved for testing only, please leave those pins connect to "L"
PARA_SERI= "H"	Parallel 24-bit RGB interface
VDPOL= "H"	VSYNC negative polarity
HDPOL= "H"	HSYNC negative polarity
DCLKPOL= "H"	DCLK negative polarity
SPI_I2C_SEL= "H"	3-Wire SPI
VDIR= "H"	Vertical scan direction= L1->L2->..... ->L(last line)
HDIR= "H"	Horizontal scan direction= Y1->Y2->.....->Y(last data)

Note: For detailed pin description please refer to section 6.1 PIN DESCRIPTION.

10.3 Serial 8-bit RGB with 3-wire SPI

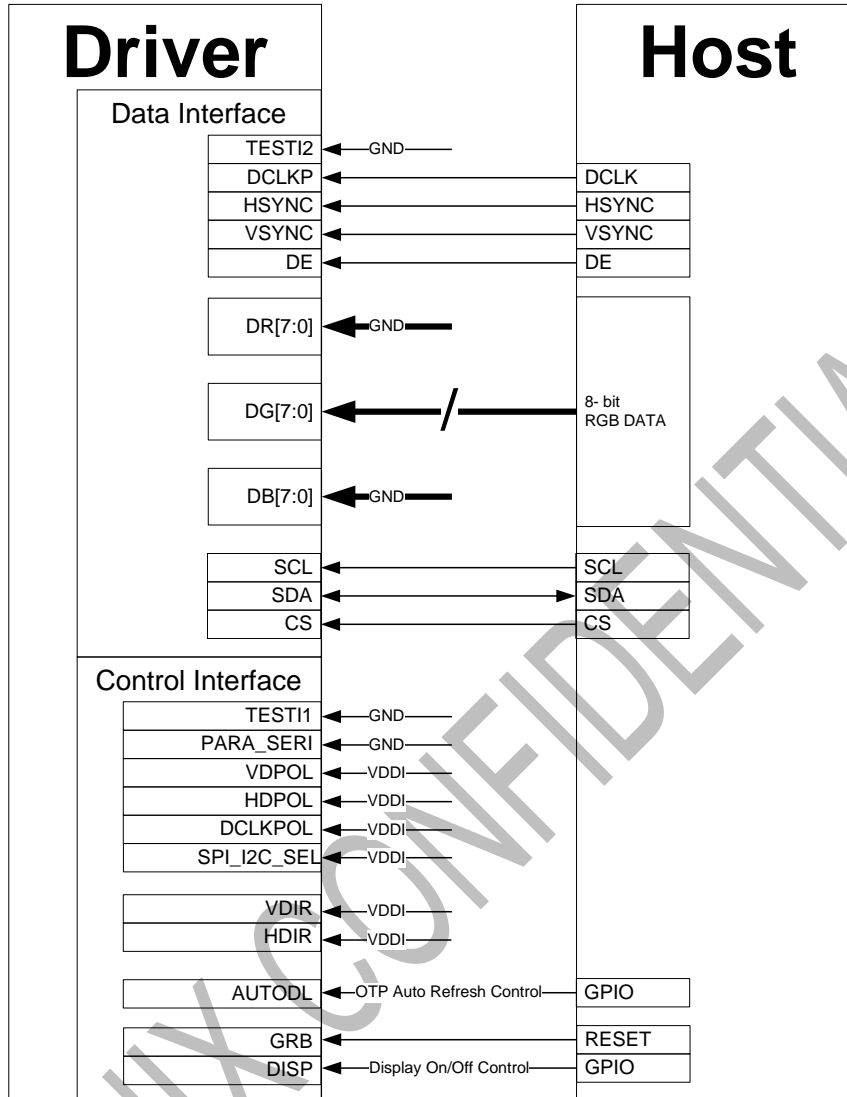

Pin Connection	Description
TESTI[2:1]	Reserved for testing only, please leave those pins connect to "L"
PARA_SERI = "L"	Serial 8-bit RGB interface
VDPOL= "H"	VSYNC negative polarity
HDPOL= "H"	HSYNC negative polarity
DCLKPOL= "H"	DCLK negative polarity
SPI_I2C_SEL= "H"	3-Wire SPI
VDIR= "H"	Vertical scan direction= L1->L2->.....->L(last line)
HDIR= "H"	Horizontal scan direction= Y1->Y2->.....->Y(last data)

Note: For detailed pin description please refer to section 6.1 PIN DESCRIPTION.

10.4 OTP Operation

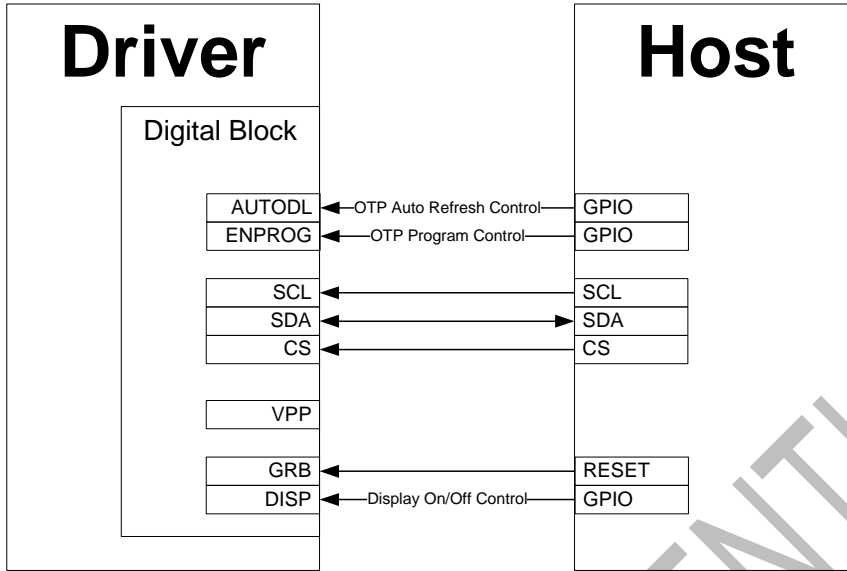

Pin Connection	Description
AUTODL	OTP auto-refresh function control
ENPROG	OTP program function control
VPP	Reserved for testing only, please leave this pin open.

Note: For detailed pin description please refer to section 6.1 PIN DESCRIPTION.

11. POWER ON/OFF SEQUENCE

11.1 Power On Sequence

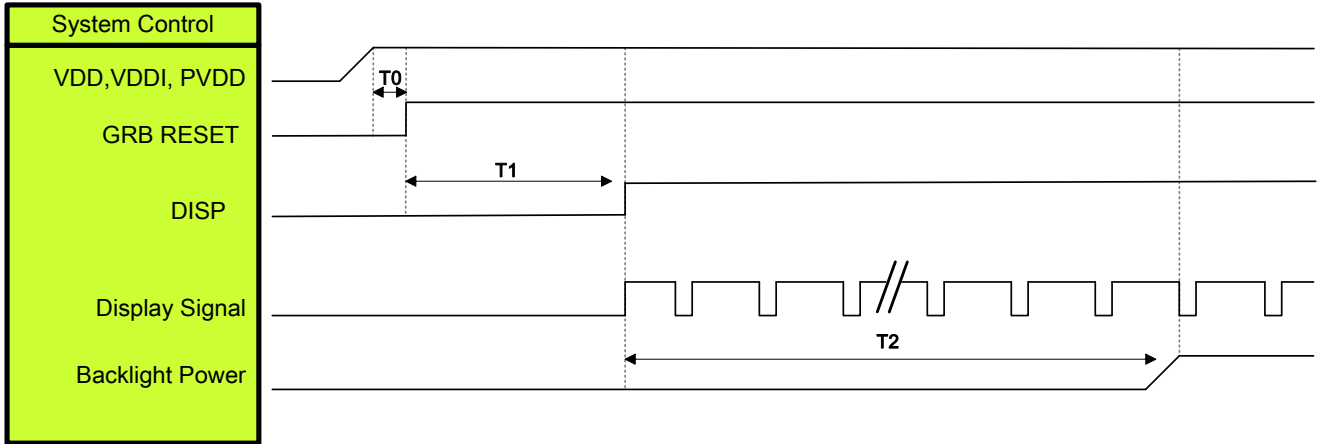

Symbol	Description	Min. Time	Unit
T0	System power stability to GRB RESET signal	0	ms
T1	GRB RESET= "High" to DISP="High"	10	ms
T2	Display Signal output to Backlight Power on	250	ms

Note: Display signal: DCLK; VSYNC; HSYNC; DE; DR[7:0]; DG[7:0]; DB[7:0]

11.2 Power Off Sequence

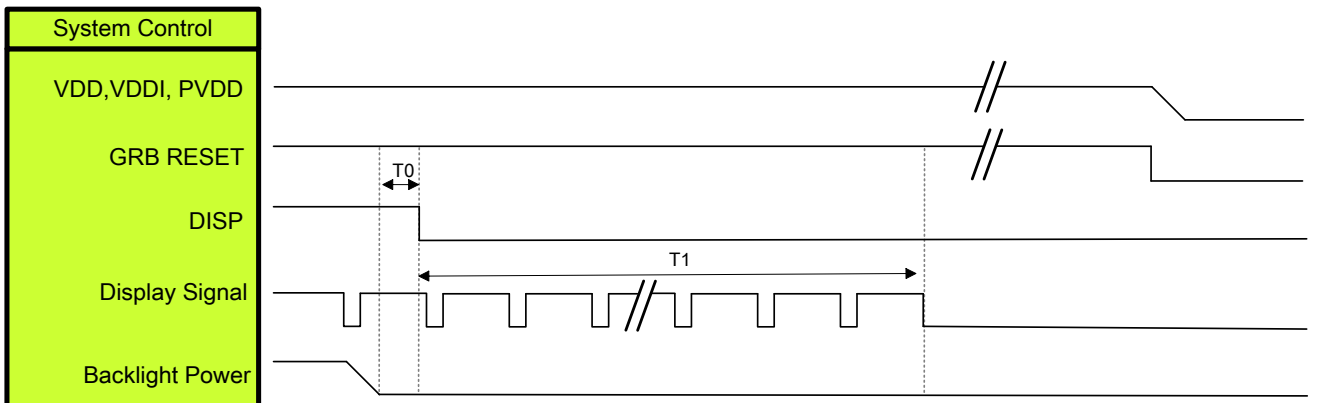

Symbol	Description	Min. Time	Unit
T0	Backlight Power off to DISP="Low"	5	ms
T1	DISP="Low" to IC internal voltage discharge complete	80	ms

Note: Display signal: DCLK; VSYNC; HSYNC; DE; DR[7:0]; DG[7:0]; DB[7:0]

12. BIST FUNCTION

When "BIST\_EN" pin sets to "H", the BIST function is enabled. The BIST pattern will automatically display BIST pattern in the BIST mode as follows.

12.1 BIST Pattern

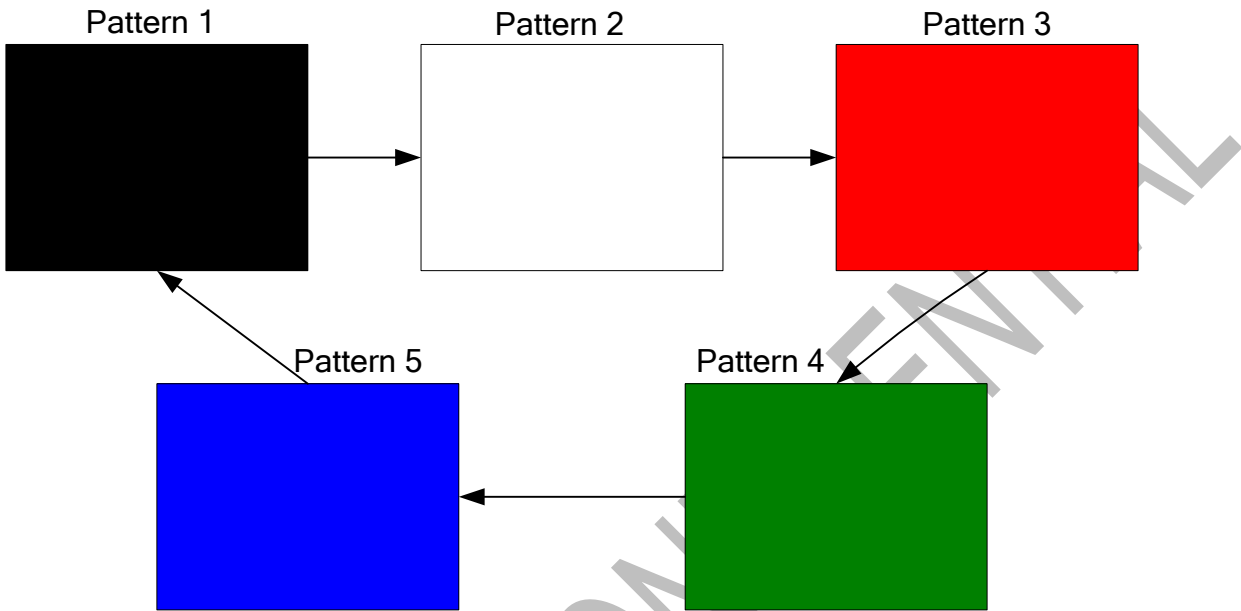



13. OTP PROGRAM FLOW

13.1 VCOM Offset OTP Flow

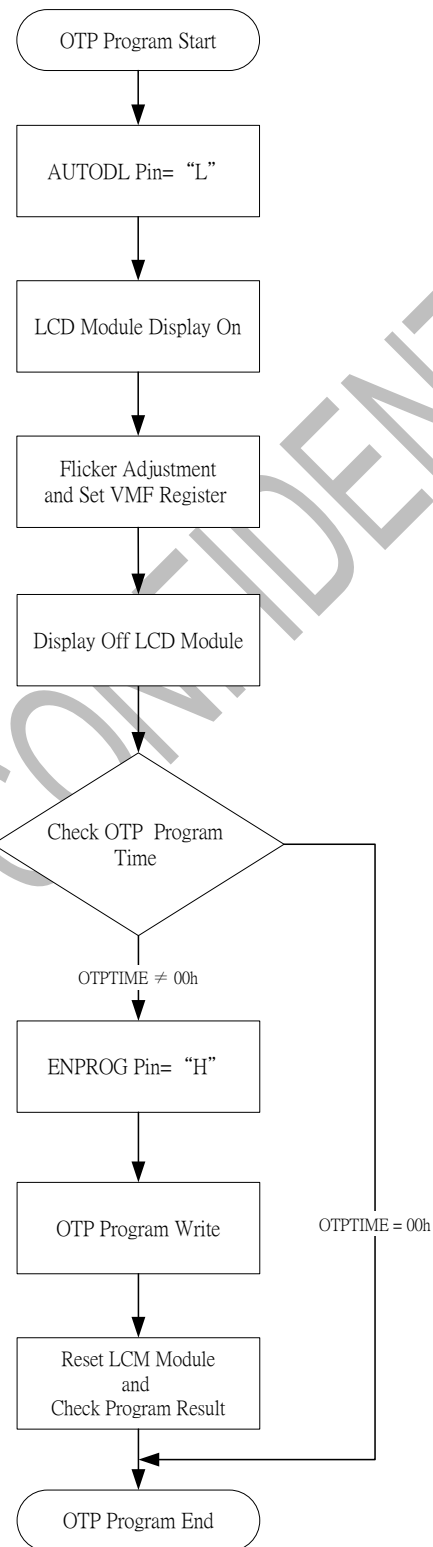

```
void Set_VMF_Register ()
{
    Write(Command,0x05);           //Flicker adjustment and VMF[6:0] register setting
    Write(Data, VMF);
}
```

```
void Check_OTP_Program_Time()
{
    Write(Command,0x66);           //VMF OTPTIME register address
    Read(Data, VMFOTPTIME);
}
```

```
void OTP_Program_Write()
{
    Write(Command,0x60);           //OTP write function enable
    Write(Data,0x46);
    Write(Command,0x65);           //OTP ACK= 0x3A
    Write(Data,0x3A);
}
```

```
void Check_Program_Result()
{
    Write(Command,0x05);           //Read VMF[6:0] register setting
    Read(Data, VMF);
}
```

13.2 Custom Application ID Code OTP Flow

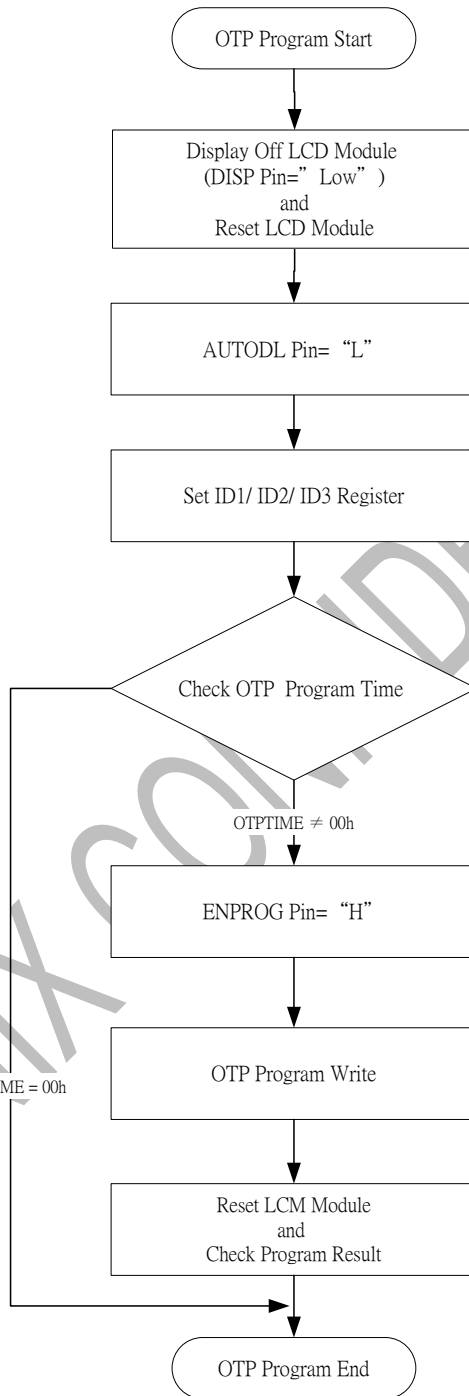

```
void Set_OTP_Register ()
{
    Write(Command,0x01);           //The parameter should be adjusted by the customer
    Write(Data, ID);              //ID= 0x01, ID2= 0x02, ID3= 0x03
}

void Check_OTP_Program_Time()
{
    Write(Command,0x69);           //The parameter should be adjusted by the customer;
    Read(Data, IDOTPTIME);        //MF OTPTIME= 0x6A, MF OTPTIME= 0x6A
}                                  //DS OTPTIME= 0x6B

void OTP_Program_Write()
{
    Write(Command,0x60);           //OTP write function enable
    Write(Data,0x46);
    Write(Command,0x65);          // The parameter should be adjusted by the customer;
    Write(Data,0x31);             // ID ACK= 0x31, ID2 ACK= 0x32, ID3 ACK= 0x33
}

void Check_Program_Result ()
{
    Write(Command,0x01);           // The parameter should be adjusted by the customer
    Read(Data, ID);               // ID= 0x01, ID2= 0x02, ID3= 0x03
}
```



15. COLOR FILTER ARRANGEMENT

The IC supports the stripe color filter of dual-gate application. The color filter arrangement on panel is shown below.

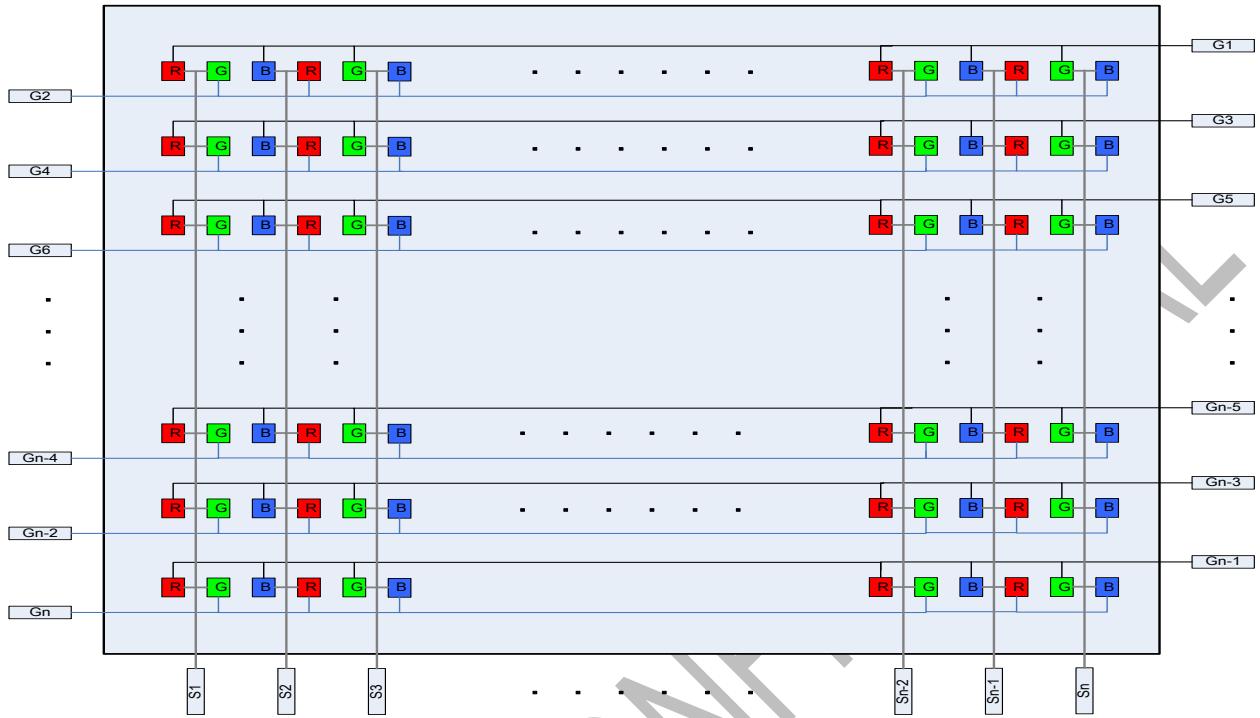

16. SOURCE VOLTAGE RELATIONS

The relations between VCOM and source voltage is shown as below:

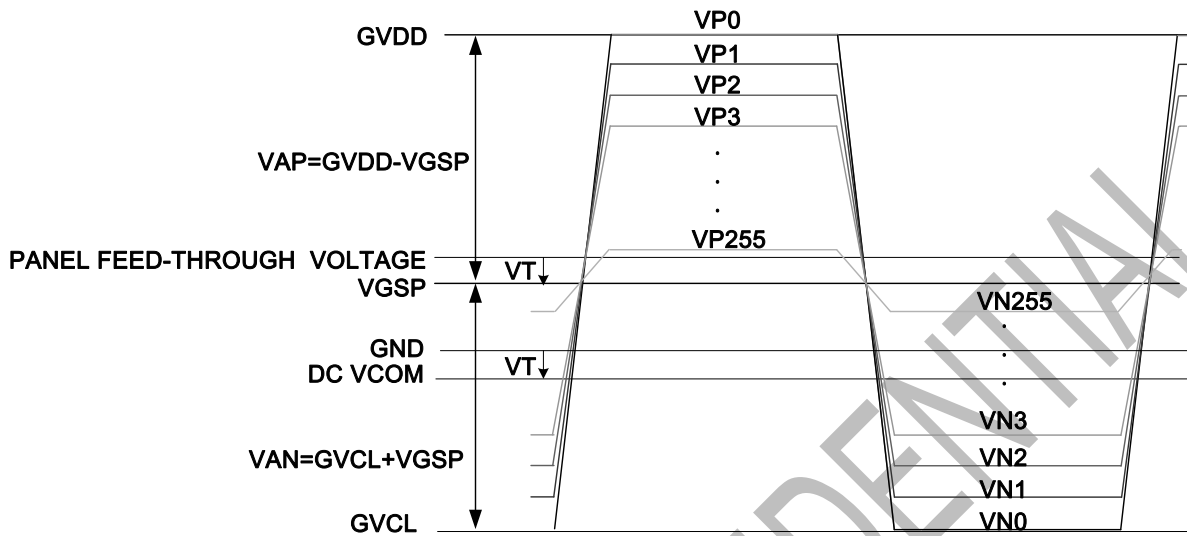

Note: The IC source support maximum LC driving voltage VAP (VAN): 5.224V [ (GVDD-VGSP )=(VGSP-GVCL)=(GVDD-GVCL)/ 2 ].

The driver compensate the panel feed-through voltage VT: VCOM+ VGSP

**17. REVISION HISTORY**

Revision	Description	Date
Draft 0.1	1 <sup>st</sup> edition	2017/11
Draft 0.2	2 <sup>nd</sup> edition	2018/01
Version 0.3	3 <sup>rd</sup> edition	2018/01
Version 0.4	Add Bump Dimension (P8) Add Alignment Mark (P9) Modify Power On/ Off Sequence (P79)	2018/03

SITRONIX CONFIDENTIAL