



# PRODUCT SPECIFICATION

CDTECH Model: **S121BWX05ED**

CUSTOMER Model: **-**

Description: **12.1" TFT-LCD Module**

Version: **1.0**

CDTECH	PREPARED BY	CHECKED BY	APPROVED BY
SIGNATURE			
DATE	2023.5.23	2023.5.23	2023.5.23

CUSTOMER APPROVAL	SIGNATURE	DATE





---

## Contents

1. General Specifications .....	4
2. Absolute Maximum Ratings .....	4
3. Electrical Characteristics .....	5
4. Interface Pin Assignment .....	7
5. Interface Characteristics .....	8
6. Optical Specifications .....	15
7. Reliability Test Items .....	18
8. Mechanical Drawing .....	19
9. Packing .....	20
10. Precautions for Use of LCD modules .....	21

# 1. General Specifications

## 1.1 LCM General Information

Item	Specification	Unit
LCD Size	12.1	inch
Number of Pixels	1280 (H) RGB x 800 (V)	pixels
Display Mode	Normally Black	-
Viewing Direction	Free	o' clock
Interface	LVDS	-
Display Colors	16.7M	colors
Outline Dimension	277.7 (H) x 180.6 (V) x 7.5 (D)	mm
Active Area	261.12 (H) x 163.2 (V)	mm
Pixel Pitch	0.204 (H) x 0.204 (V)	mm
Driver IC	-	-
Operation Temperature	-20~70	°C
Storage Temperature	-30~80	°C

Note1:Requirements on environmental protection RoHS compliant.

## 2. Absolute Maximum Ratings

Item	Symbol	MIN.	MAX.	Unit	Note
Analog Supply voltage	VDD	-0.3	5.0	V	Note 1

Note 1:Permanent damage may occur to the LCD module if beyond this specification.

Functional operation should be restricted to the conditions described under normal operating conditions.

### 3. Electrical Characteristics

#### 3.1 Recommended Operating Condition for TFT LCD

Item	Symbol	Min.	Typ.	Max.	Unit	Note
Analog Supply voltage	VDD	3.0	3.3	3.6	V	
Analog supply current	I <sub>VDD</sub>	-	TBD	-	mA	VDD=3.3V
Logic input voltage	V <sub>IH</sub>	0.7*VDD	-	VDD	V	
	V <sub>IL</sub>	GND	-	0.3*VDD	V	

#### 3.2 Recommended Driving Condition for Backlight

Item	Symbol	Min.	Typ.	Max.	Unit	Note
Driving Current	I <sub>F</sub>	-	360	-	mA	
Driving Voltage	V <sub>F</sub>	23.0	-	26.5	V	
Power consumption	W <sub>BL</sub>	8.28	-	9.54	W	
LED Life-Time	N/A	-	30,000	-	Hours	Ta=25°C Note 1

Note 1:LED lifetime is defined as the module brightness decay 50% of original brightness at Ta=25 degree, typical current.

Note 2:LED circuit :

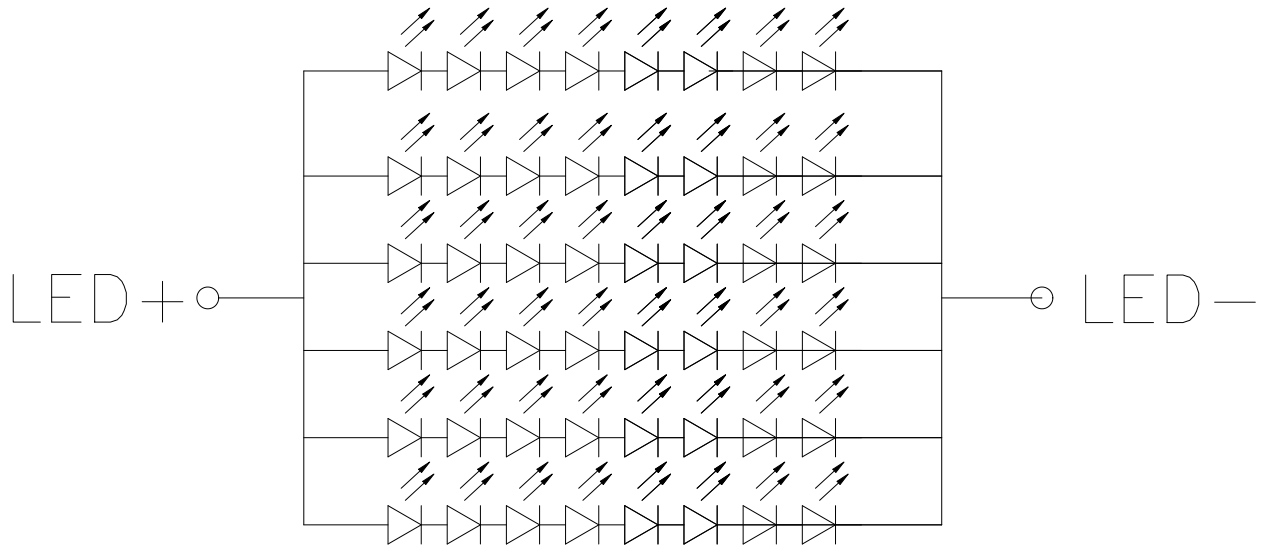

## 4. Interface Pin Assignment

### 4.1 LCM Pin Assignment

No.	Symbol	Description
1	NC	No connection
2-4	VDD	Power Supply
5	NC	No connection
6-7	GND	Ground
8	Rin0-	- LVDS differential data input
9	Rin0+	+ LVDS differential data input
10	GND	Ground
11	Rin1-	- LVDS differential data input
12	Rin1+	+ LVDS differential data input
13	GND	Ground
14	Rin2-	- LVDS differential data input
15	Rin2+	+ LVDS differential data input
16	GND	Ground
17	LVDS_CLK-	LVDS CLOCK differential signal input pins
18	LVDS_CLK+	LVDS CLOCK differential signal input pins
19	GND	Ground
20	Rin3-	- LVDS differential data input
21	Rin3+	+ LVDS differential data input
22	GND	Ground
23-24	NC	No connection
25	GND	Ground
26-27	NC	No connection
28	GND	Ground
29-30	NC	No connection
31-33	GND	Ground
34-40	NC	No connection

## 5. Interface Characteristics

### 5.1 LVDS Rx Interface Timing Parameter

The specification of the LVDS Rx interface timing parameter is shown in Table 8.

<Table 8. LVDS Rx Interface Timing Specification>

Item	Symbol	Min	Typ	Max	Unit	Remark
CLKIN Period	tRCP	10	T	40	nsec	
Receiver Data Input Margin	tRMG	-0.45	-	+0.45	nsec	fCLKIN=80.9MHz
		-0.60	-	+0.60	nsec	fCLKIN=75MHz
Input Data 0	tRIP1	-   tRMG	0.0	tRMG	Clock	
Input Data 1	tRIP0	T/7-   tRMG	T/7	T/7+   tRMG	Clock	
Input Data 2	tRIP6	2 T/7-   tRMG	2T/7	2T/7+   tRMG	Clock	
Input Data 3	tRIP5	3T/7-   tRMG	3T/7	3T/7+   tRMG	Clock	
Input Data 4	tRIP4	4T/7-   tRMG	4T/7	4T/7+   tRMG	Clock	
Input Data 5	tRIP3	5T/7-   tRMG	5T/7	5T/7+   tRMG	Clock	
Input Data 6	tRIP2	6T/7-   tRMG	6T/7	6T/7+   tRMG	Clock	

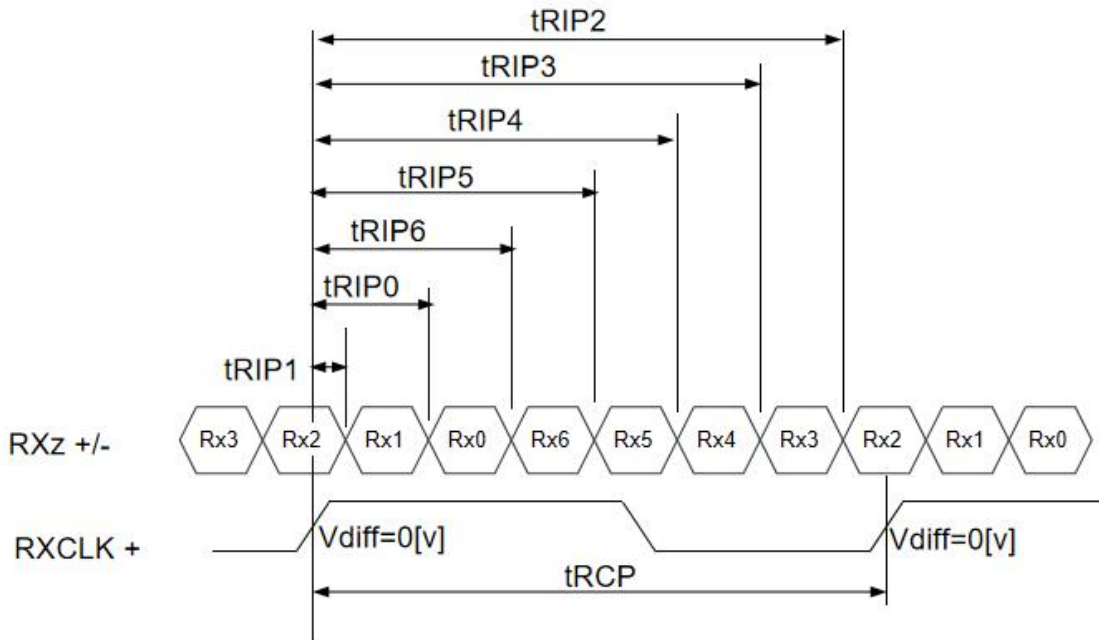

\* Vdiff = (RXz+)-(RXz-),.....,(RXCLK+)-(RXCLK-)



## 5.2 DC Specification

- LVDS Receiver Differential Input ( DC Characteristics )

< Table 9-1. LVDS Rx DC Characteristics >

Parameter	Symbol	Min	Typ	Max	Unit	Notes
Differential Input High Threshold Voltage	$V_{TH}$	-	-	+100	mV	VCM=1.2V
Differential Input Low Threshold Voltage	$V_{TL}$	-100	-	-	mV	
Differential Input Common Mode Voltage	VCM	1	1.2	1.4	V	
Differential Input Voltage	$ V_{ID} $	200	-	600	mV	

Single-end Signals

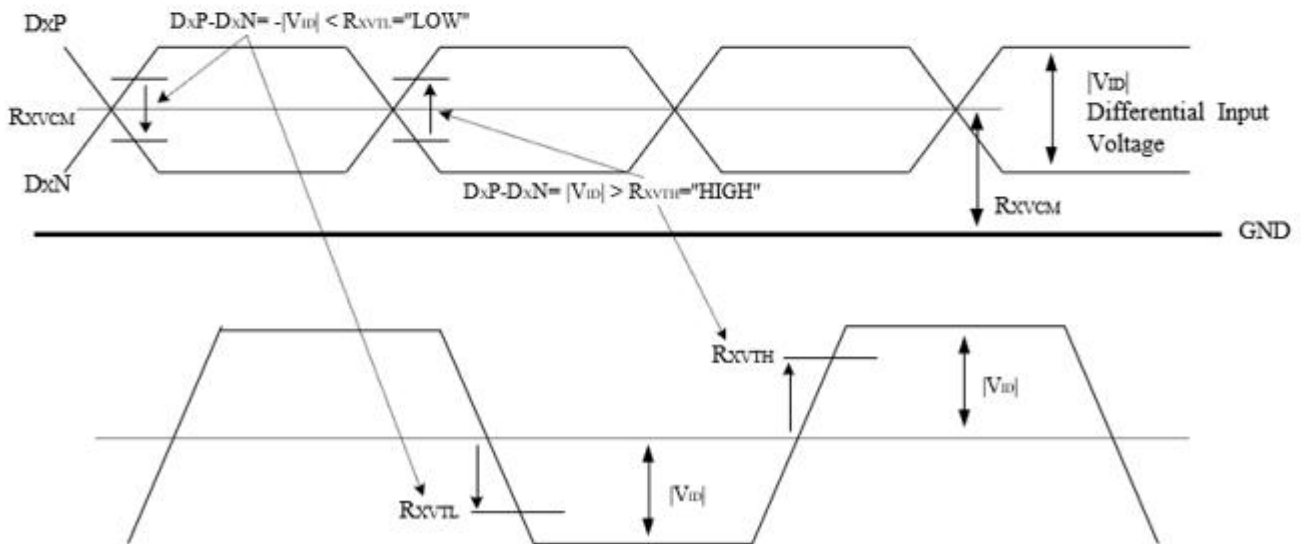

## 5.3 AC Specification

- LVDS Receiver Differential Input ( AC Characteristics )

< Table 9-2. LVDS Rx AC Characteristics >

Parameter	Symbol	Min	Typ	Max	Unit	Notes
LVDS Strobe Width	t <sub>SW</sub>	200	-	-	ps	V <sub>cm</sub> =1.2V VID = 200mV @81MHz
LVDS Receiver Skew Margin	t <sub>RSKM</sub>	500	-	-	ps	

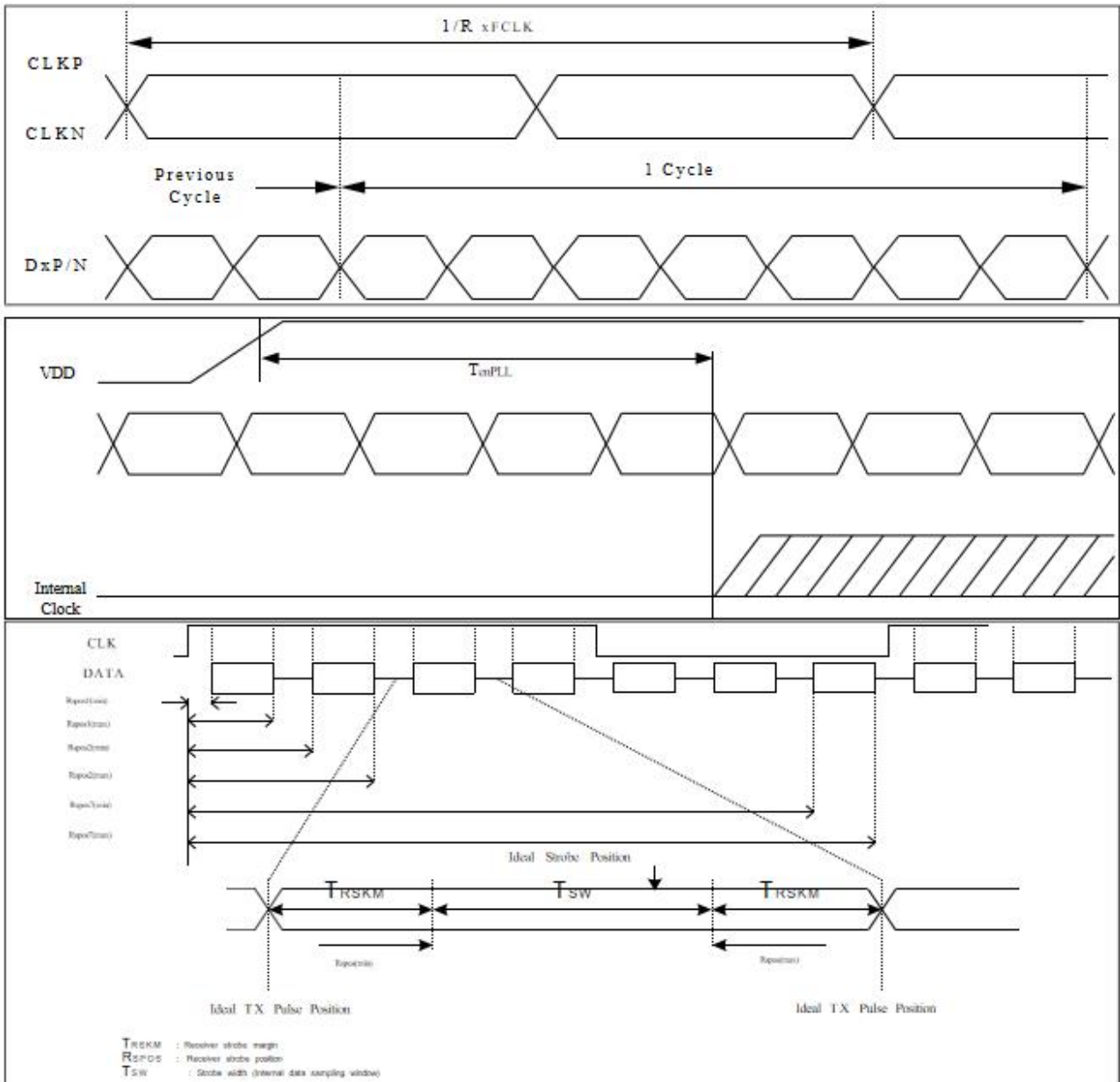

## 5.4 Interface timing Parameter

### 5.4.1 Timing Parameters (DE only mode)

For 1280RGBx800

Parameter	Symbol	Value			Unit
		Min.	Typ.	Max.	
DCLK frequency @Frame rate=60Hz (LVDS)	F <sub>DCLK</sub>	66.3	72.4	78.9	MHz
HSYNC period time	T <sub>H</sub>	1380	1440	1500	DCLK
Horizontal display area	T <sub>HD</sub>	1280			DCLK
HSYNC pulse width	T <sub>HPW</sub>	Min.	2		
		Typ.	-		
		Max.	40		
HSYNC back porch(with pulse width)	T <sub>HBP</sub>	88	88	88	DCLK
HSYNC front porch	T <sub>HFP</sub>	12	72	132	DCLK
VSYNC period time	T <sub>V</sub>	824	838	872	H
Vertical display area	T <sub>VD</sub>	800			H
VSYNC pulse width	T <sub>VPW</sub>	Min.	2		H
		Typ.	-		
		Max.	20		
VSYNC back porch(with pulse width)	T <sub>VBP</sub>	23	23	23	H
VSYNC front porch	T <sub>VFP</sub>	1	15	49	H

For 1280RGBx800 DE mode

Parameter	Symbol	Value			Unit
		Min.	Typ.	Max.	
DCLK frequency @Frame rate=60Hz (LVDS)	F <sub>DCLK</sub>	69.7	75	80.9	MHz
Horizontal display area	T <sub>HD</sub>	1280			DCLK
HSYNC period time	T <sub>H</sub>	1380	1440	1500	DCLK
HSYNC blanking	T <sub>HBP</sub> +T <sub>HFP</sub>	100	160	220	DCLK
Vertical display area	T <sub>VD</sub>	800			H
VSYNC period time	T <sub>V</sub>	842	838	872	H
VSYNC blanking	T <sub>VBP</sub> +T <sub>VFP</sub>	24	38	72	H

#### Note

1. DE Only Mode, While operation, DE signal should be have the same cycle. The input of HSYNC & VSYNC signal does not have an effect on normal operation.
2. Best operation clock frequency is 75Mhz.
3. Frequency] = [H Total] \* [V Total] \* [vertical Frame rate]  
H Total, V Total and Frame rate]should operate within the range between Frequency\_Min and Frequency\_Max
4. Except Best operation clock frequency, FOS(Flicker & Brightness & Crosstalk, Etc.) are not guaranteed.
5. Main frequency Max is 80.9Mhz MHz without spread spectrum

## 5.5 Signal Timing Waveform

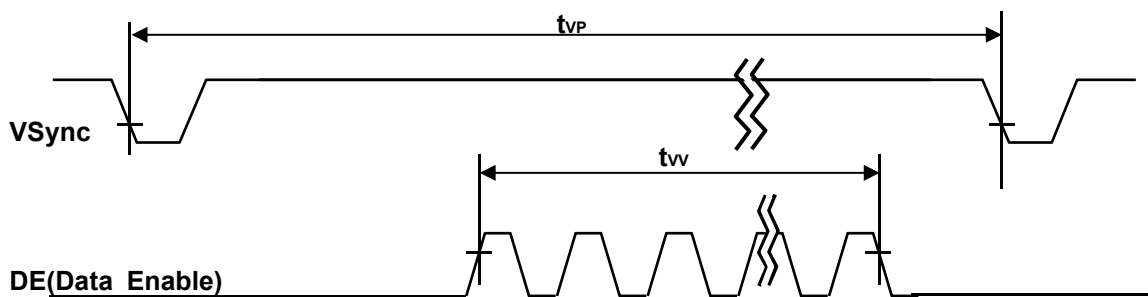
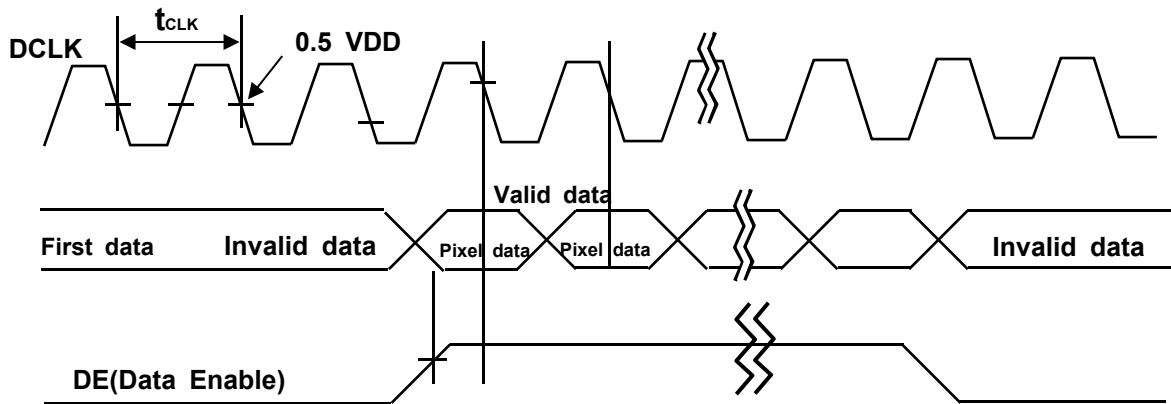



## 5.6 Input Signals, Basic Display Colors and Gray Scale of Colors

< Table 12. Input Signal and Display Color Table >

Color & Gray Scale		Input Data Signal																							
		Red Data								Green Data				Blue Data											
		R7	R6	R5	R4	R3	R2	R1	R0	G7	G6	G5	G4	G3	G2	G1	G0	B7	B6	B5	B4	B3	B2	B1	B0
Basic Colors	Black	0	0	0	0	0	0	0	0	0	0	0	0	0	0	0	0	0	0	0	0	0	0	0	0
	Blue	0	0	0	0	0	0	0	0	0	0	0	0	0	0	0	0	1	1	1	1	1	1	1	1
	Green	0	0	0	0	0	0	0	0	1	1	1	1	1	1	1	1	0	0	0	0	0	0	0	0
	Cyan	0	0	0	0	0	0	0	0	1	1	1	1	1	1	1	1	1	1	1	1	1	1	1	1
	Red	1	1	1	1	1	1	1	1	0	0	0	0	0	0	0	0	0	0	0	0	0	0	0	0
	Magenta	1	1	1	1	1	1	1	1	0	0	0	0	0	0	0	0	1	1	1	1	1	1	1	1
	Yellow	1	1	1	1	1	1	1	1	1	1	1	1	1	1	1	1	0	0	0	0	0	0	0	0
	White	1	1	1	1	1	1	1	1	1	1	1	1	1	1	1	1	1	1	1	1	1	1	1	1
Gray Scale of Red	Black	0	0	0	0	0	0	0	0	0	0	0	0	0	0	0	0	0	0	0	0	0	0	0	
	△	0	0	0	0	0	0	0	1	0	0	0	0	0	0	0	0	0	0	0	0	0	0	0	
	Darker	0	0	0	0	0	0	0	1	0	0	0	0	0	0	0	0	0	0	0	0	0	0	0	
	△																								
	▽																								
	Brighter	1	1	1	1	1	1	0	1	0	0	0	0	0	0	0	0	0	0	0	0	0	0	0	
	▽	1	1	1	1	1	1	1	0	0	0	0	0	0	0	0	0	0	0	0	0	0	0	0	
	Red	1	1	1	1	1	1	1	1	0	0	0	0	0	0	0	0	0	0	0	0	0	0	0	0
Gray Scale of Green	Black	0	0	0	0	0	0	0	0	0	0	0	0	0	0	0	0	0	0	0	0	0	0	0	
	△	0	0	0	0	0	0	0	0	0	0	0	0	0	0	0	1	0	0	0	0	0	0	0	
	Darker	0	0	0	0	0	0	0	0	0	0	0	0	0	0	1	0	0	0	0	0	0	0	0	
	△																								
	▽																								
	Brighter	0	0	0	0	0	0	0	0	1	1	1	1	1	1	0	1	0	0	0	0	0	0	0	
	▽	0	0	0	0	0	0	0	0	1	1	1	1	1	1	0	0	0	0	0	0	0	0	0	
	Green	0	0	0	0	0	0	0	0	1	1	1	1	1	1	1	1	0	0	0	0	0	0	0	0
Gray Scale of Blue	Black	0	0	0	0	0	0	0	0	0	0	0	0	0	0	0	0	0	0	0	0	0	0	0	
	△	0	0	0	0	0	0	0	0	0	0	0	0	0	0	0	0	0	0	0	0	0	0	1	
	Darker	0	0	0	0	0	0	0	0	0	0	0	0	0	0	0	0	0	0	0	0	0	0	1	
	△																								
	▽																								
	Brighter	0	0	0	0	0	0	0	0	0	0	0	0	0	0	0	1	1	1	1	1	1	1	0	
	▽	0	0	0	0	0	0	0	0	0	0	0	0	0	0	0	1	1	1	1	1	1	1	0	
	Blue	0	0	0	0	0	0	0	0	0	0	0	0	0	0	0	1	1	1	1	1	1	1	1	
Gray Scale of White	Black	0	0	0	0	0	0	0	0	0	0	0	0	0	0	0	0	0	0	0	0	0	0	0	
	△	0	0	0	0	0	0	0	1	0	0	0	0	0	0	0	1	0	0	0	0	0	0	1	
	Darker	0	0	0	0	0	0	1	0	0	0	0	0	0	0	1	0	0	0	0	0	0	0	1	
	△																								
	▽																								
	Brighter	1	1	1	1	1	1	0	1	1	1	1	1	1	0	1	1	1	1	1	1	1	0	1	
	▽	1	1	1	1	1	1	1	0	1	1	1	1	1	1	0	1	1	1	1	1	1	1	0	
	White	1	1	1	1	1	1	1	1	1	1	1	1	1	1	1	1	1	1	1	1	1	1	1	

## 5.7 POWER SEQUENCE

To prevent a latch-up or DC operation of the Open Cell, the power on/off sequence shall be as shown in below

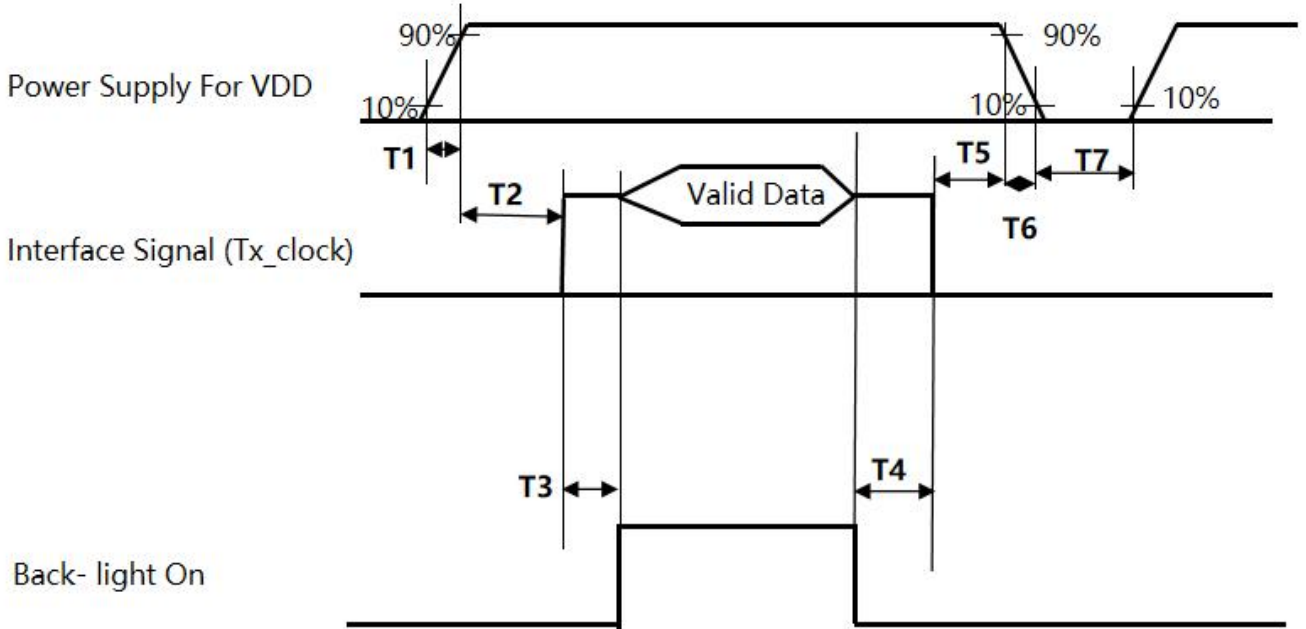

Parameter	Values			Units
	Min	Typ	Max	
T1	0.1	-	10	ms
T2	0.1	-	50	ms
T3	300	-	-	ms
T4	200	-	-	ms
T5	0.1	-	50	s
T6	0.1	-	10	ms
T7	500	-	-	ms

Note 1: Even though T1 is over the specified value, there is no problem if the rush current is within Spec.

Note 2: When the power supply VDD is 0V, keep the level of input signals on the low or high impedance;

※ Please avoid floating state of interface signal at invalid period.

※ When the power supply for LCD (VDD) is off, be sure to pull down the valid and invalid data to 0V.

Note 3: The T3 / T4 is recommended value, the case when failed to meet a minimum specification, abnormal display would be shown. There is no reliability problem.

Note 4: T6: Voltage of VDD must decay smoothly after power-off, there should be none re-bouncing voltage. (customer system decide this value)

Note 5: T7 should be measured after the Module has been fully discharged between power off and on period

## 6. Optical Specifications

Item	Symbol	Condition	Min.	Typ.	Max.	Unit	Note
Viewing Angle (CR≥10) B/L ON	$\theta_T$	$\Phi=90^\circ$ (12 o'clock)	80	85	-	deg	Note2
	$\theta_B$	$\Phi=270^\circ$ (6 o'clock)	80	85	-	deg	Note2
	$\theta_L$	$\Phi=180^\circ$ (9 o'clock)	80	85	-	deg	Note2
	$\theta_R$	$\Phi=0^\circ$ (3 o'clock)	80	85	-	deg	Note2
Response Time	$T_{ON}$	Normal $\theta=\Phi=0^\circ$	-	15	17	msec	Note4
	$T_{OFF}$		-	15	17	msec	Note4
Contrast Ratio	CR		1000	1200	-	-	Note1 Note3
Color Chromaticity	$W_X$		TBD	TBD	TBD	-	Note1 Note5
	$W_Y$		TBD	TBD	TBD	-	Note1 Note5
Luminance	L		800	1000	-	cd/m <sup>2</sup>	Note1 Note7
Luminance Uniformity	$Y_U$		70	80	-	%	Note1 Note6
NTSC	-		68	72	-	%	-

Note 1: Definition of optical measurement system

The optical characteristics should be measured in dark room. After 5 minutes operation, the optical properties are measured at the center point of the LCD screen. All input terminals LCD panel must be ground when measuring the center area of the panel.

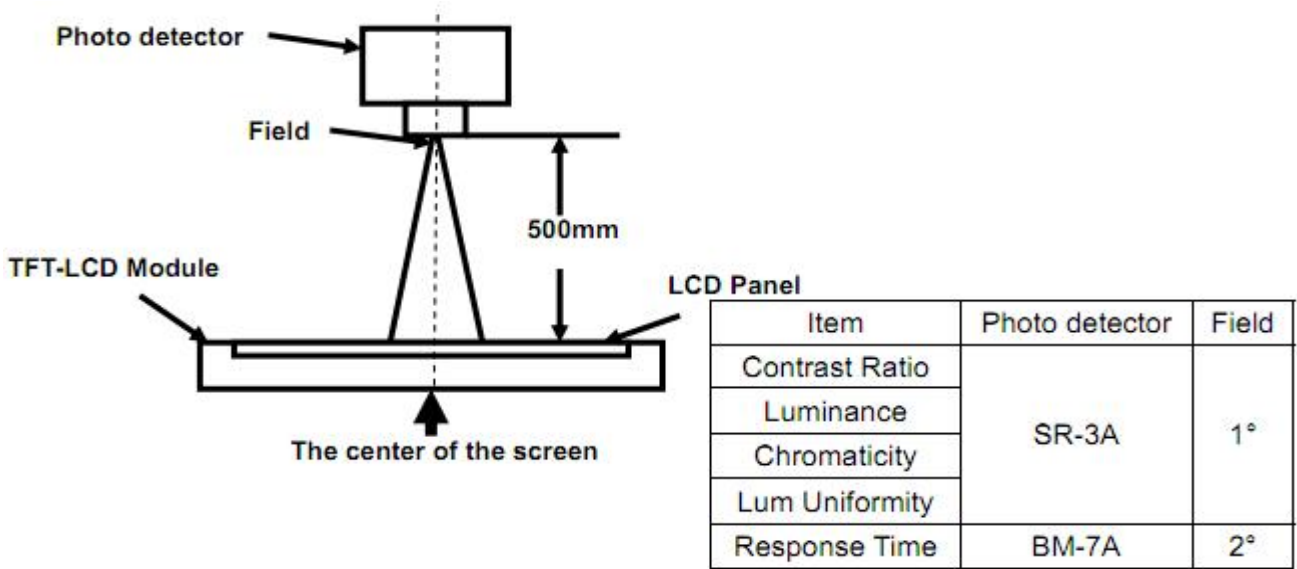

Note 2: Definition of viewing angle range and measurement system  
Viewing angle is measured at the center point of the LCD by CONOSCOPE(ergo-80).

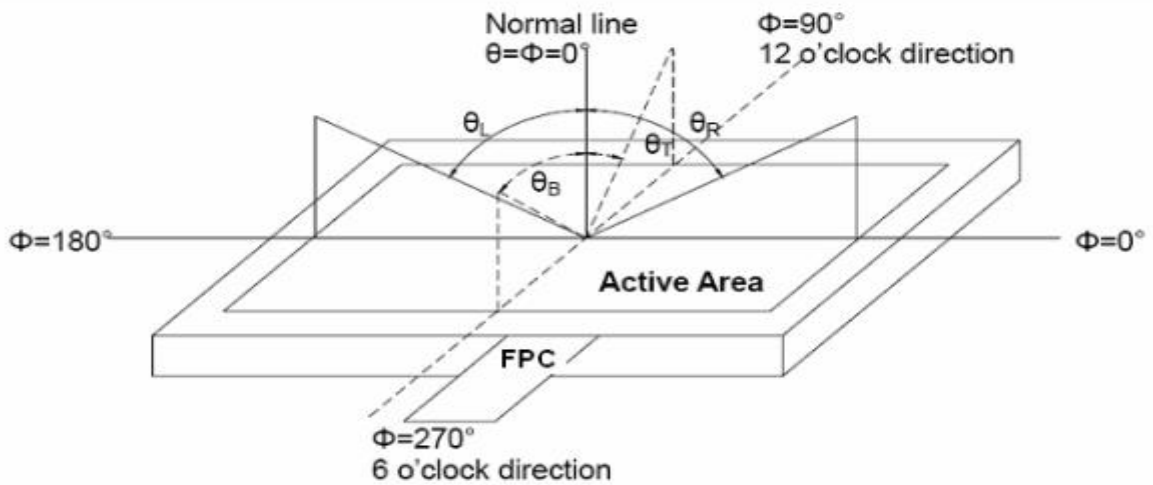

Fig. 1 Definition of viewing angle

Note 3: Definition of contrast ratio

$$CR = \frac{\text{Luminance with all pixels white}}{\text{Luminance with all pixels black}}$$



**Note 4: Definition of Response time**

The response time is defined as the LCD optical switching time interval between “White” state and “Black”state. Rise time (TON) is the time between photo detector output intensity changed from 90% to 10%. And fall time (TOFF) is the time between photo detector output intensity changed from 10% to 90%.

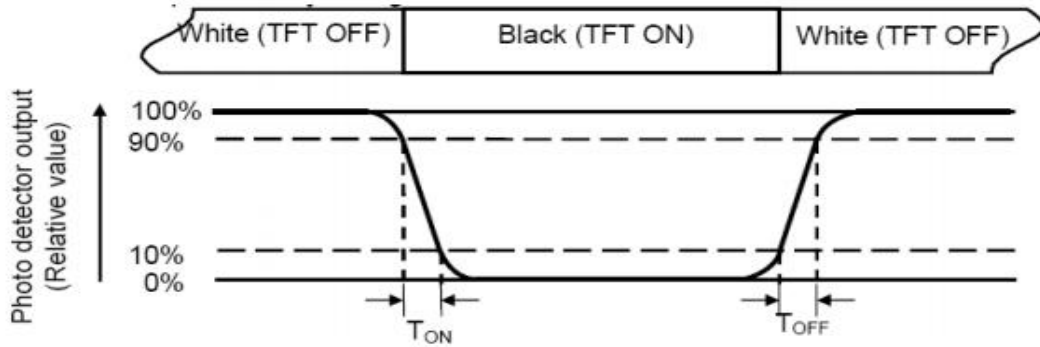

**Note 5: Definition of color chromaticity (CIE1931)**

Color coordinates measured at center point of LCD.

**Note 6: Definition of Luminance Uniformity**

The luminance uniformity in surface luminance is determined by measuring luminance at each test position 1 through n, and then dividing the maximum luminance of n points luminance by minimum luminance of n points luminance. For more information see FIG.2.

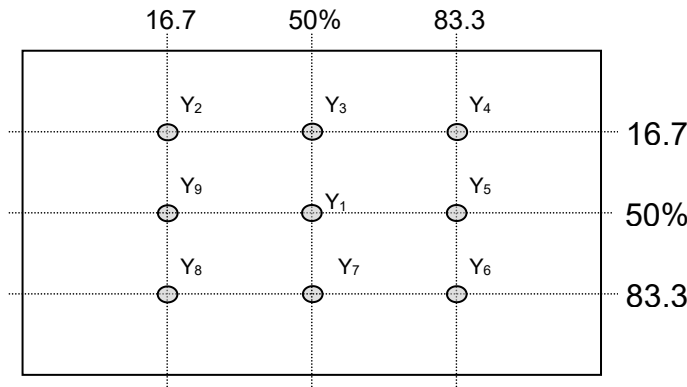

Fig. 2 Definition of points

**Note 7: Definition of Luminance (Refer Fig. 2)**

Surface luminance is the luminance with all pixels displaying white.

$L_v = \text{Average Surface Luminance with all white pixels}(P_1, P_2, P_3, \dots, P_n)$ .

## 7. Reliability Test Items

Test Item	Test Conditions
High Temperature Storage	Ta= +80°C 96hrs
Low Temperature Storage	Ta= -30°C 96hrs
High Temperature Operation	Ta= +70°C 96hrs
Low Temperature Operation	Ta= -20°C 96hrs
High Temperature and Humidity Storage	Ta= +60°C, 90% RH 96hrs
Thermal Shock (Non-operation)	-30°C/30 min ~ +80°C/30 min for 20 cycles Start with cold temperature end with high temperature
Electro Static Discharge	Contact = ± 4 kV, class B Air = ± 8 kV, class B R=330Ω,C=150pF
Vibration	Sweep: 10Hz~55Hz~10Hz Stroke: 1.5mm 2 hrs for each direction of X .Y. Z.
Mechanical Shock	60G 6ms,±X,±Y,±Z 3 times for each direction
Package Drop Test	Height: 60 cm 1 corner, 3 edges, 6 surfaces

Notes: The test result shall be evaluated after the sample has been left at room temperature and humidity for 2 hours without load. No condensation shall be accepted. The sample will not be accepted if appear these defects:

- 1). Air bubble in the LCD
- 2). Seal leak or Glass crack
- 3). Non display or abnormal display
- 4). Brightness reduction >50%

### 8. Mechanical Drawing

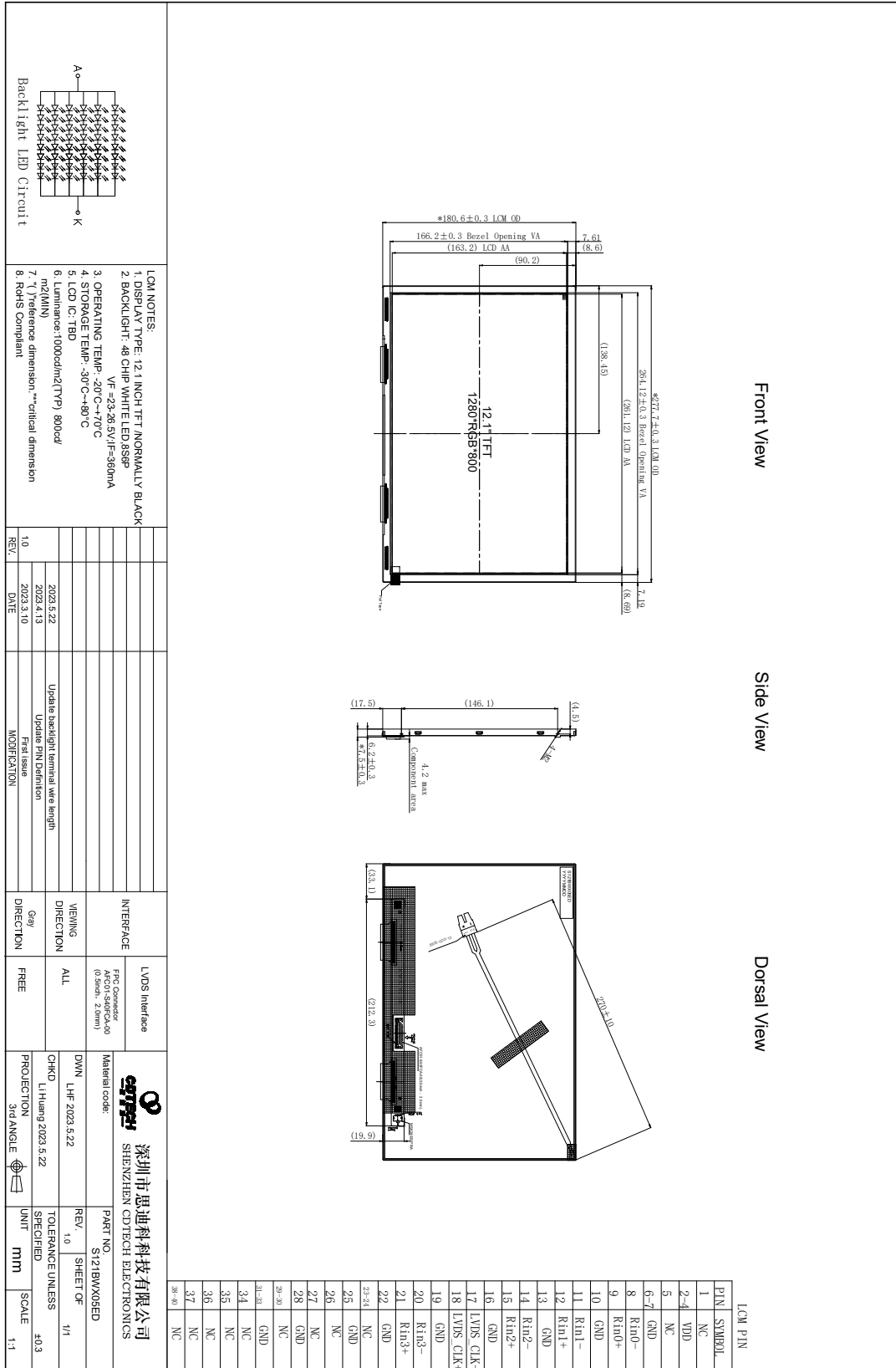

## 9. Packing

### Packing Method

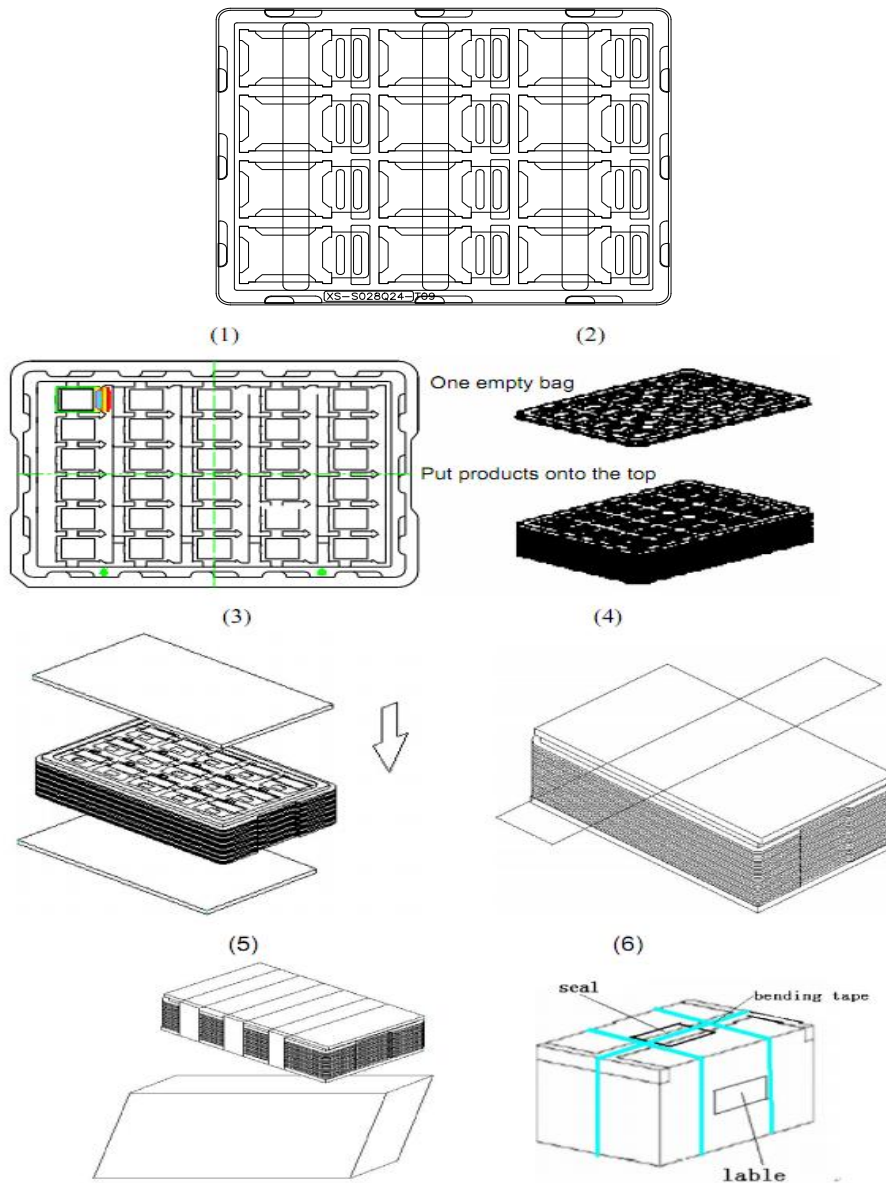

Steps:

1. Put module into tray cavity
2. Tray stacking
3. Put 1 cardboard under the tray stack and 1 cardboard above
4. Fix the cardboard to the tray stack with adhesive tape
5. Put the tray stack into carton
6. Carton sealing with adhesive tape

## 10. Precautions for Use of LCD modules

### 10.1 Handling Precautions

10.1.1. The display panel is made of glass. Do not subject it to a mechanical shock by dropping it from a high place, etc.

10.1.2. If the display panel is damaged and the liquid crystal substance inside it leaks out, be sure not to get any in your mouth, if the substance comes into contact with your skin or clothes, promptly wash it off using soap and water.

10.1.3. Do not apply excessive force to the display surface or the adjoining areas since this may cause the color tone to vary.

10.1.4. The polarizer covering the display surface of the LCD module is soft and easily scratched. Handle this polarizer carefully.

10.1.5. If the display surface is contaminated, breathe on the surface and gently wipe it with a soft dry cloth. If still not completely clear, moisten cloth with one of the following solvents:

- Isopropyl alcohol
- Ethyl alcohol

Solvents other than those mentioned above may damage the polarizer. Especially, do not use the following:

- Water
- Ketene
- Aromatic solvents

10.1.6. Do not attempt to disassemble the LCD Module.

10.1.7. If the logic circuit power is off, do not apply the input signals.

10.1.8. To prevent destruction of the elements by static electricity, be careful to maintain an optimum work environment.

10.1.8.1. Be sure to ground the body when handling the LCD Modules.

10.1.8.2. Tools required for assembly, such as soldering irons, must be properly ground.

10.1.8.3. To reduce the amount of static electricity generated, do not conduct assembly and other work under dry conditions.

10.1.8.4. The LCD Module is coated with a film to protect the display surface. Be care when peeling off this protective film since static electricity may be generated.

### 10.2 Storage Precautions

10.2.1. When storing the LCD modules, avoid exposure to direct sunlight or to the light of fluorescent lamps.

10.2.2. The LCD modules should be stored under the storage temperature range if the LCD modules will be stored for a long time, the recommend condition is :

Temperature : 0°C ~40°C    Relatively humidity: ≤80%

10.2.3. The LCD modules should be stored in the room without acid, alkali and harmful gas.

### 10.3 Transportation Precautions

The LCD modules should be no falling and violent shocking during transportation, and also should avoid excessive press, water, damp and sunshine.