

## Product Specification

<b>Model Name</b>	S040HWV08NN-DC03
<b>Description</b>	Standard LCD Module 4.0" WVGA 480(RGB)x480 Dots
<b>Date</b>	2022/9/6
<b>Version</b>	1.0

<b>Approved by/Date</b>	<b>Check by/Date</b>	<b>Prepared by/Date</b>
ZHP 2022/9/06	HZX 2022/9/06	ZWF 2022/9/06

<b>Customer Approval</b>	
<b>Date</b>	



# CDTech(H.K.)Electronics Limited

## Table of Contents

<b>1. Record of Revision .....</b>	<b>3</b>
<b>2. General Specifications .....</b>	<b>4</b>
<b>3. Input/Output Terminals .....</b>	<b>5</b>
<b>4. Absolute Maximum Rating .....</b>	<b>6</b>
<b>7. Optical Characteristics .....</b>	<b>16</b>
<b>8. Environmental / Reliability Tests .....</b>	<b>19</b>
<b>9. Mechanical Drawing .....</b>	<b>20</b>
<b>10. Packing .....</b>	<b>21</b>
<b>11. Precautions for Use of LCD modules .....</b>	<b>22</b>



## 1. Record of Revision

Rev	Issued Date	Description	Editor
1.0	2019/7/20	First Release.	Yigui.Han
	2022/9/6	Update IIS	ZWF

## 2. General Specifications

	Feature	Spec
Characteristics	Size	4.0 inch
	Resolution	480(horizontal)*480(Vertical)
	Interface	RGB-24bit
	Connect type	Connector
	Display Colors	16.7M
	Technology type	a-Si
	Pixel pitch (mm)	0.149*0.146
	Pixel Configuration	R.G.B-Stripe
	Display Mode	Normally Black
	LCD Driver IC	ST7701-G5
	CTP Driver IC	GT911
	Viewing Direction	Full view
Mechanical	LCM (W x H x D) (mm)	86.0*86.0*3.9
	Active Area(mm)	71.86 x70.18
	With /Without TSP	With CTP
	Weight (g)	TBD
	LED Numbers	10 LEDs

Note 1: Requirements on Environmental Protection: RoHs

Note 2: LCM weight tolerance: +/- 5%

## 3. Input/Output Terminals

No.	Symbol	Description
1	GND	Ground
2	VLED+	Backlight LED Anode.
3	VLED-	Backlight LED Cathode
4	VCC	Power supply 3.3V
5	IOVCC	Power supply 1.8V
6	SDO	Serial output signal
7	SDI	Serial Data Input
8	GND	Ground
9	SCL-WR	Serial Clock
10	CS	Chip select pin
11	NC	No connect
12	RESET	Reset signal pin
13~20	R0~R7	Data bus
21~28	G0~G7	Data bus
29~36	B0~B7	Data bus
37	DE	Data enable input. Active high to enable the input data bus under "DE Mode."
38	GND	Ground
39	PCLK	Dot clock signal input. Latching input data at its rising edge.
40	GND	Ground
41	HSYNC	Horizontal sync input. Negative polarity.
42	VSYNC	Vertical sync input. Negative polarity..
43	IC-ID	No connect
44	LED-PWM	The PWM frequency output for LCD driver control.
45	GND	Ground

## CTP PIN-MAP

Pin	Signal	Description
1	VSS	Ground
2	/INT	Interrupt request to the host
3	/RST	Reset Pin for CTP
4	VSS	Ground
5	SCL	I2C clock input
6	SDA	I2C data input and output
7	VSS	Ground
8	VSS	Ground
9	VDD	Power supply for CTP
10	VDD	Power supply for CTP

## 4. Absolute Maximum Rating

Item	Symbol	MIN	Typ	MAX	Unit	Remark
Supply Voltage	VDD	-0.5	-	5	V	-
Digital supply voltage	IOVCC	-0.3	-	3.6	V	
Operating Temperature	TOPR	-20	-	70	°C	-
Storage Temperature	TSTG	-30	-	80	°C	

## 5. Electrical Characteristics

### 5.1 Driving TFT LCD Panel

Item	Symbol	Min.	Typ.	Max.	Unit	Note
Analog Supply voltage	VDD	3.0	3.3	3.6	V	
Analog supply current	I <sub>VDD</sub>	20	30	40	mA	VDD=3.3V
Logic supply voltage	IOVCC	1.65	1.8	3.3	V	
Logic supply current	I <sub>IOVCC</sub>	3	5	10	mA	IOVCC=1.8V
Logic input voltage	VIH	0.7*IOVCC	-	IOVCC	V	
	VIL	GND	-	0.3*IOVCC	V	

## 5.2 CTP Electrical Characteristics

FPC Design	Item	Description	Remark
COF	IC solution on TP Model	GT911	
	Touch Count Max	5 point	
	Display Resolution	480*480	
	Interface Type	I2C	
	I2C Slave Address	0X28	
	Origin of Coordinate	Top left corner	

Parameter	Symbol	Min	Typ	Max	Unit
Interface Signal Voltage	VDDI	-	3.3	-	V
Power Voltage	VDD	-	3.3	-	V
Power current	IDD	10	15	20	mA

## 5.3 LED Driving Conditions

Item	Symbol	MIN	TYP	MAX	Unit	Remark
Forward Current	$I_F$	-	40	-	mA	
Forward Voltage	$V_F$	13.8	15	16.2	V	
Backlight Power consumption	$W_{BL}$	-	0.6	-	W	
LED Lifetime		-	30000	-	Hrs	

Note 1: Each LED:  $I_F = 20 \text{ mA}$ ,  $V_F = 3.2 \pm 0.2 \text{ V}$ .

Note 2: Optical performance should be evaluated at  $T_a = 25^\circ \text{C}$  only.

Note 3: If LED is driven by high current, high ambient temperature & humidity condition. The life Time of LED will be reduced. Operating life means brightness goes down to 50% initial brightness. Typical operating life time is estimated data.

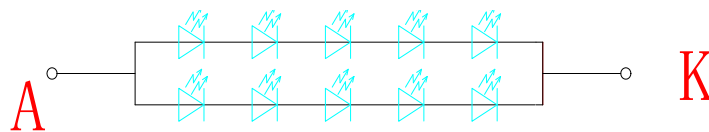
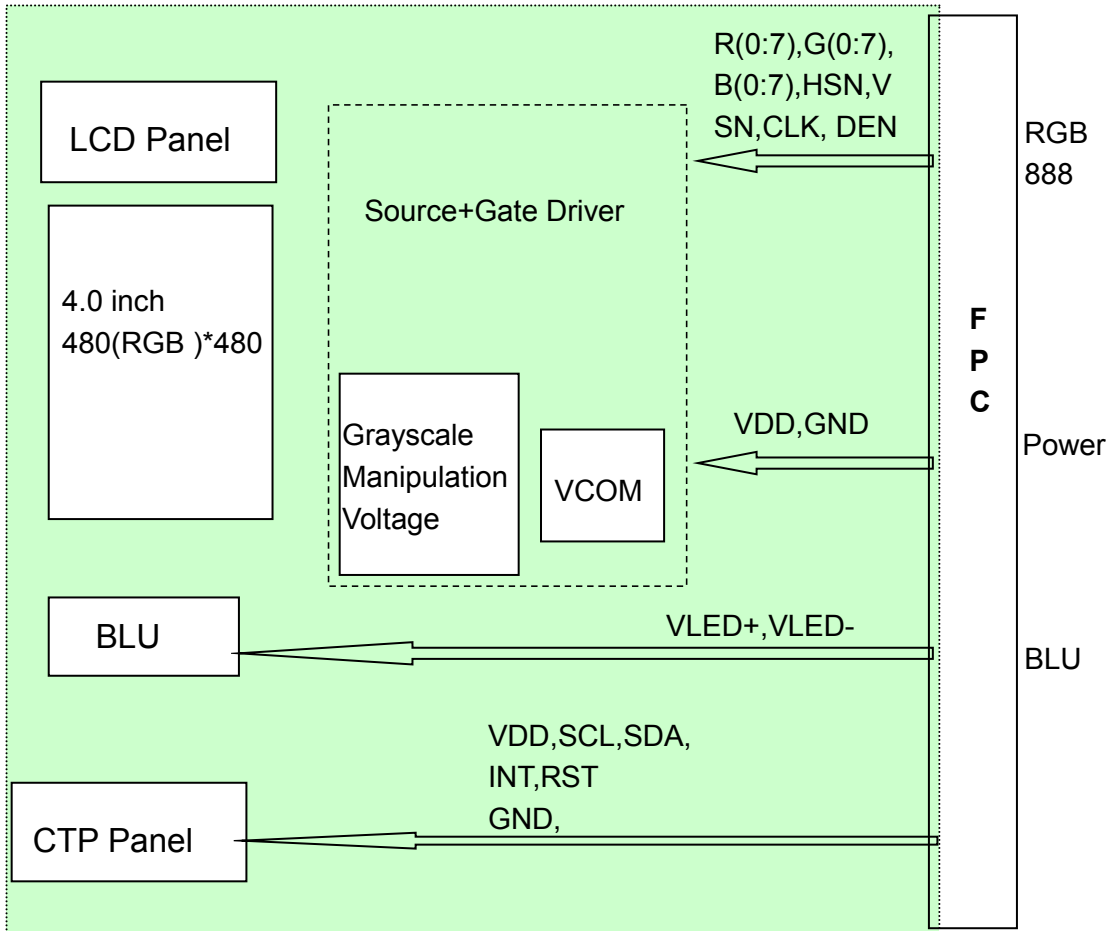

Figure: LED connection of backlight(Constant Current)

## 5.4 Black Diagram





## 6. Interface Timing

### 6.1 Serial Interface Characteristics (3-line serial):

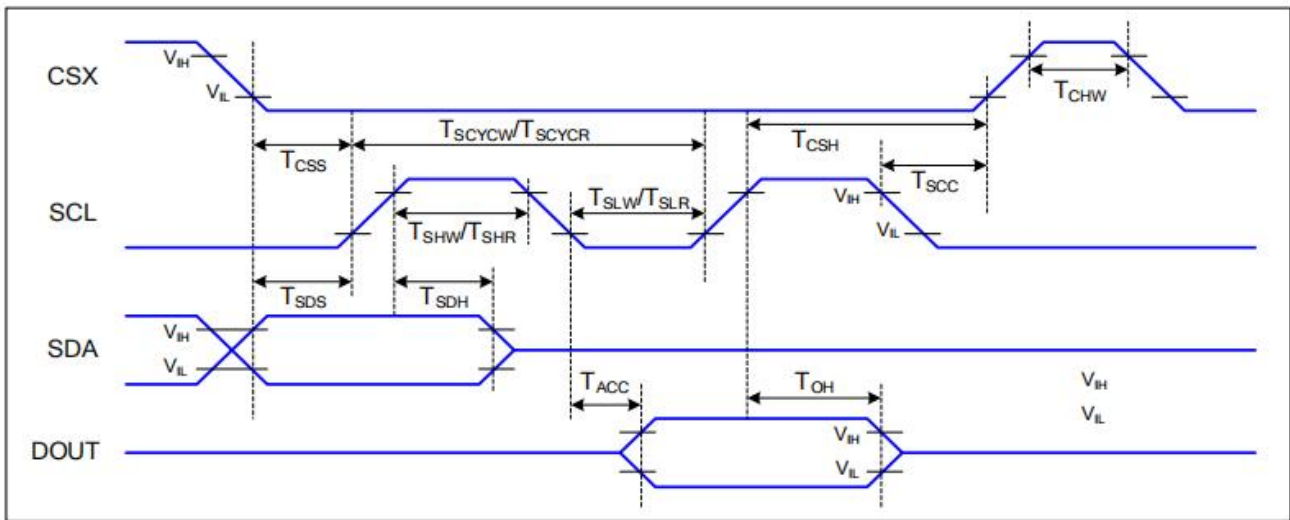

### 3-line serial Interface Timing Characteristics

Signal	Symbol	Parameter	Min	Max	Unit	Description
CSX	$T_{CSS}$	Chip select setup time (write)	15		ns	
	$T_{CSH}$	Chip select hold time (write)	15		ns	
	$T_{CSS}$	Chip select setup time (read)	60		ns	
	$T_{SCC}$	Chip select hold time (read)	60		ns	
	$T_{CHW}$	Chip select "H" pulse width	40		ns	
SCL	$T_{SCYCW}$	Serial clock cycle (Write)	66		ns	
	$T_{SHW}$	SCL "H" pulse width (Write)	15		ns	
	$T_{SLW}$	SCL "L" pulse width (Write)	15		ns	
	$T_{SCYCR}$	Serial clock cycle (Read)	150		ns	
	$T_{SHR}$	SCL "H" pulse width (Read)	60		ns	
	$T_{SLR}$	SCL "L" pulse width (Read)	60		ns	
SDA (DIN)	$T_{SDS}$	Data setup time	10		ns	
	$T_{SDH}$	Data hold time	10		ns	

## 6.2 Serial Interface Characteristics (4-line serial):

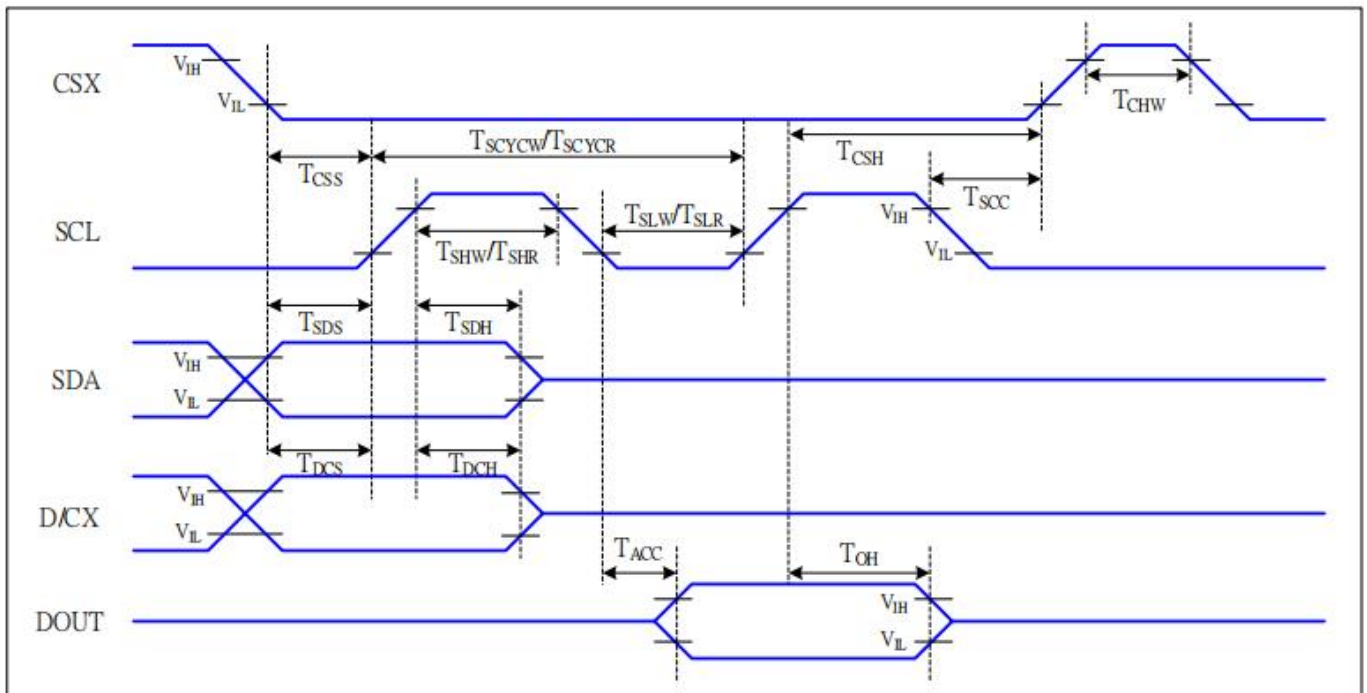

## 4-line serial Interface Timing Characteristics

Signal	Symbol	Parameter	MIN	MAX	Unit	Description
CSX	T <sub>CSS</sub>	Chip select setup time (write)	15		ns	
	T <sub>CSh</sub>	Chip select hold time (write)	15		ns	
	T <sub>CSS</sub>	Chip select setup time (read)	60		ns	
	T <sub>SCC</sub>	Chip select hold time (read)	65		ns	
	T <sub>CHW</sub>	Chip select "H" pulse width	40		ns	
SCL	T <sub>SCYCW</sub>	Serial clock cycle (Write)	66		ns	-write command & data ram
	T <sub>SHW</sub>	SCL "H" pulse width (Write)	15		ns	
	T <sub>SLW</sub>	SCL "L" pulse width (Write)	15		ns	
	T <sub>SCYCR</sub>	Serial clock cycle (Read)	150		ns	-read command & data ram
	T <sub>SHR</sub>	SCL "H" pulse width (Read)	60		ns	
	T <sub>SLR</sub>	SCL "L" pulse width (Read)	60		ns	
D/CX	T <sub>DCS</sub>	D/CX setup time	10		ns	
	T <sub>DCH</sub>	D/CX hold time	10		ns	
SDA (DIN)	T <sub>SDS</sub>	Data setup time	10		ns	
	T <sub>SDH</sub>	Data hold time	10		ns	

## 6.3 RGB Interface Characteristics :

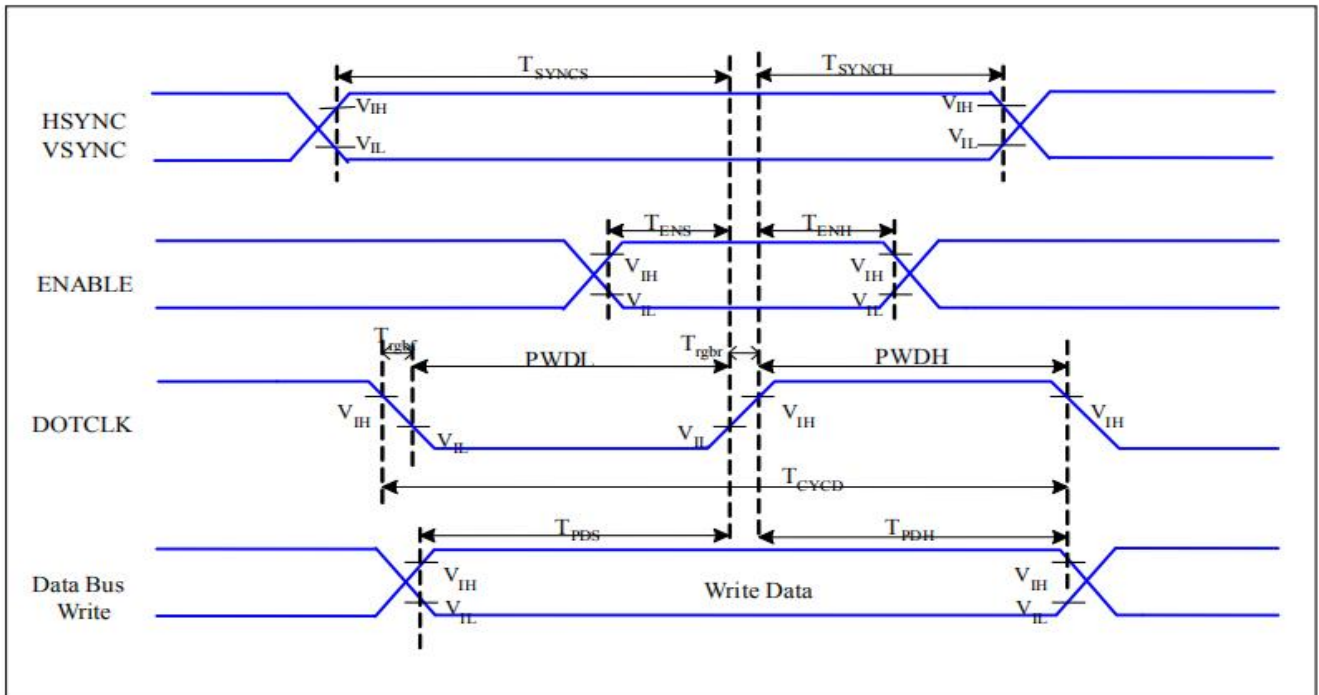

## RGB Interface Timing Characteristics

Signal	Symbol	Parameter	MIN	MAX	Unit	Description
HSYNC, VSYNC	$T_{SYNCS}$	VSUNC, HSYNC Setup Time	5	-	ns	
ENABLE	$T_{ENS}$	Enable Setup Time	5	-	ns	
	$T_{ENH}$	Enable Hold Time	5	-	ns	
DOTCLK	PWDH	DOTCLK High-level Pulse Width	15	-	ns	
	PWDL	DOTCLK Low-level Pulse Width	15	-	ns	
	$T_{CYCD}$	DOTCLK Cycle Time	33	-	ns	
	Trghr, Trghf	DOTCLK Rise/Fall time	-	15	ns	
DB	$T_{PDS}$	PD Data Setup Time	5	-	ns	
	$T_{PDH}$	PD Data Hold Time	5	-	ns	

## 6.4 The timing chart of RGB interface DE mode is shown as follows.

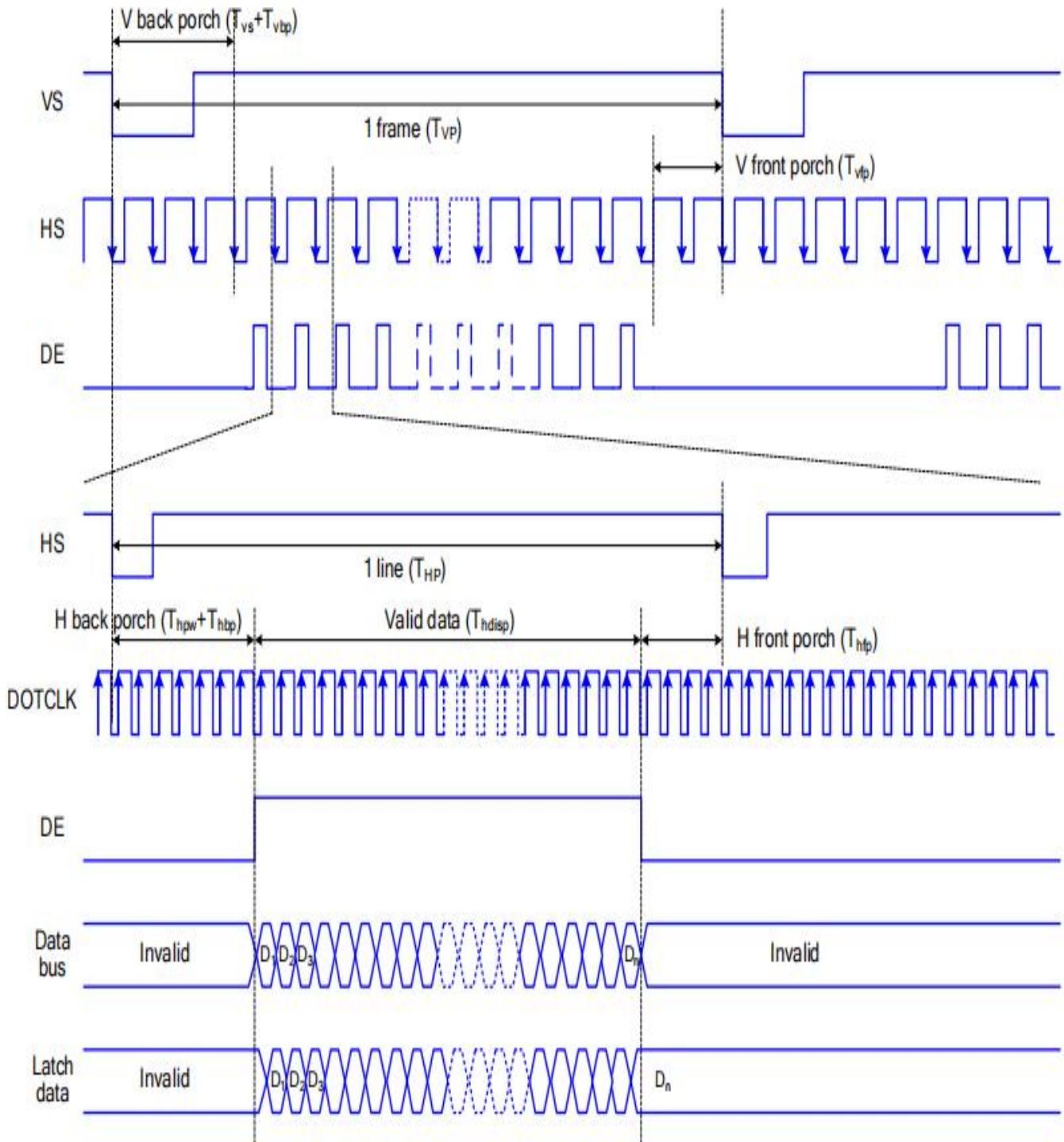



## 6.5 The timing chart of RGB interface HV mode is shown as follows

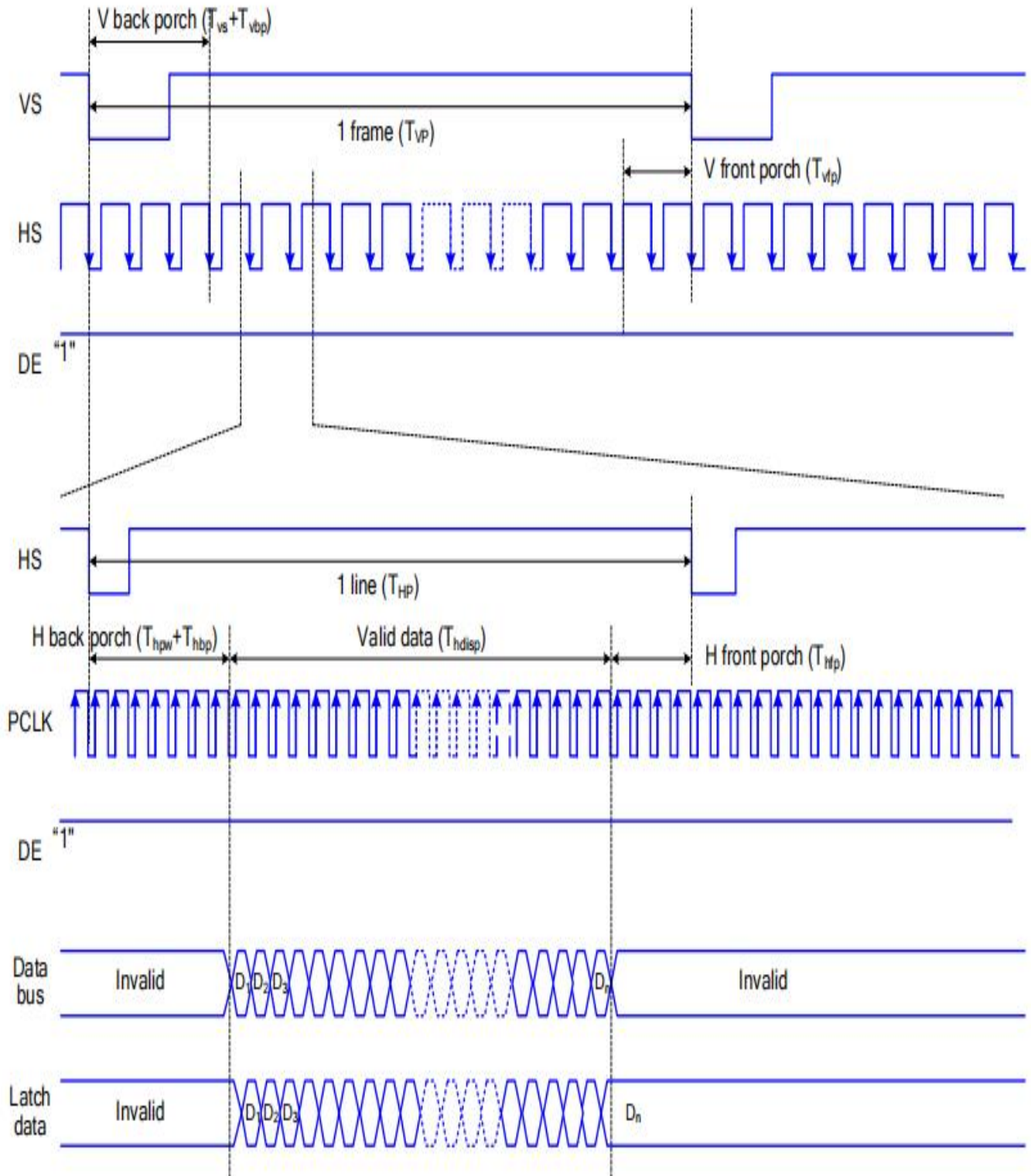

## 6.6 Capacitive touch panel Specification

### I2C

The I2C is always configured in the Slave mode. The data transfer format is shown in [Figure 2-4](#).

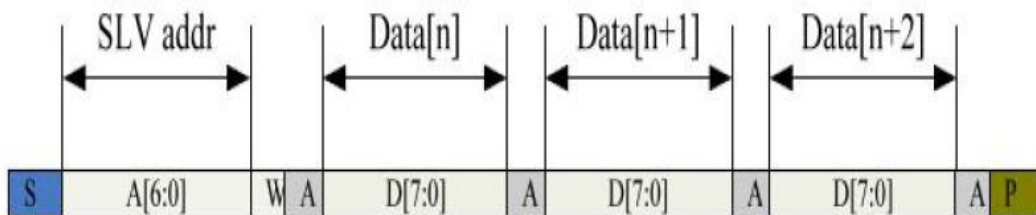
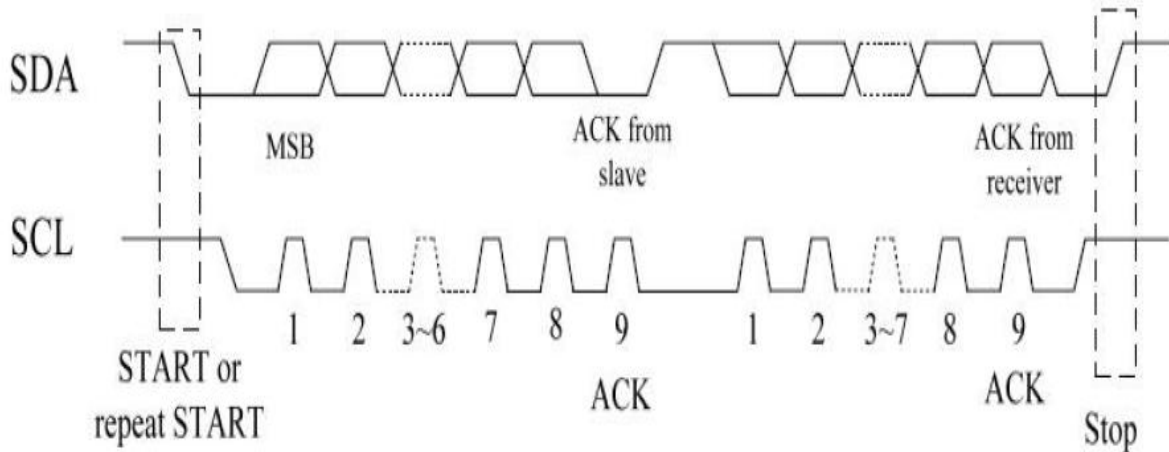

Figure 2-5 I2C master write, slave read

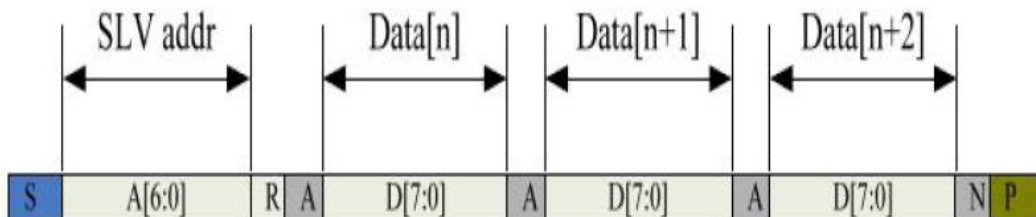

Figure 2-6 I2C master read, slave write

Table 2-1 lists the meanings of the mnemonics used in the above figures.

**Table 2-1 Mnemonics Description**

Mnemonics	Description
S	I2C Start or I2C Restart
A[6:0]	Slave address A[6:4]: 3'b011 A[3:0]: data bits are identical to those of I2CCON[7:4] register.
W	1'b0: Write
R	1'b1: Read
A(N)	ACK(NACK)
P	STOP: the indication of the end of a packet (if this bit is missing, S will indicate the end of the current packet and the beginning of the next packet)

I2C Interface Timing Characteristics is shown in Table 2-2.

**Table 2-2 I2C Timing Characteristics**

Parameter	Unit	Min	Max
SCL frequency	KHz	0	400
Bus free time between a STOP and START condition	us	4.7	\
Hold time (repeated) START condition	us	4.0	\
Data setup time	ns	250	\
Setup time for a repeated START condition	us	4.7	\
Setup Time for STOP condition	us	4.0	\

## 7. Optical Characteristics

Items		Symbol	Condition	Min.	Typ.	Max.	Unit	Remark	Note
Response time		Tr+Tf	-	-	25	35	ms	FIG.1	Note4
Contrast Ratio		CR		500	700	-	-	FIG.2	Note1
Surface luminance		LV	$\theta = 0^\circ$	-	300	-	cd/m <sup>2</sup>	FIG.2	Note2
Luminance uniformity		Yu	$\theta = 0^\circ$	70	80	-	%	FIG.2	Note3
NTSC		-	$\theta = 0^\circ$	-	50	-	%	FIG.2	Note5
Viewing angle		$\theta_T$	Center CR $\geq$ 10	-	80	-	deg	FIG.3	Note6
		$\theta_B$		-	80	-	deg	FIG.3	
		$\theta_L$		-	80	-	deg	FIG.3	
		$\theta_R$		-	80	-	deg	FIG.3	
Chromaticity	Red	R <sub>X</sub>	$\theta = 0^\circ$ $\phi = 0^\circ$ Ta=25 $^\circ$	0.5784	0.6284	0.6784	-	FIG.2 CIE1931	Note5
		R <sub>Y</sub>		0.3046	0.3546	0.4046	-		
	Green	G <sub>X</sub>		0.2914	0.3414	0.3914	-		
		G <sub>Y</sub>		0.5068	0.5568	0.6068	-		
	Blue	B <sub>X</sub>		0.0952	0.1452	0.1952	-		
		B <sub>Y</sub>		0.0297	0.0797	0.1298	-		
	White	W <sub>X</sub>		0.2511	0.3011	0.3511	-		
		W <sub>Y</sub>		0.2526	0.3026	0.3526	-		

### Note1. Definition of contrast ratio

Contrast ratio(Cr) is defined mathematically by the following formula. For more information see FIG.2.

$$\text{Contrast ratio} = \frac{\text{Luminance measured when LCD on the "White" state}}{\text{Luminance measured when LCD on the "Black" state}}$$

For contrast ratio, Surface Luminance, Luminance uniformity and CIE, the testing data is based on TOPCON's BM-5 or BM-7 photo detector or compatible.

### Note2. Definition of surface luminance.

Surface luminance is the luminance with all pixels displaying white. For more information see FIG.2.

Lv = Average Surface Luminance with all white pixels(P1,P2,P3, .....,Pn)

### Note3. Definition of luminance uniformity

The luminance uniformity in surface luminance is determined by measuring luminance at each test position 1 through n, and then dividing the maximum luminance of n points luminance by minimum luminance of n points luminance. For more information see FIG.2.

$$YU = \frac{\text{Minimum surface luminance with all white pixels (P1,P2,P3,.....,Pn)}}{\text{Maximum surface luminance with all white pixels (P1,P2,P3,.....,Pn)}}$$



**Note4. Definition of response time**

The response time is defined as the LCD optical switching time interval between “White” state and “Black”state. Rise time ( $T_r$ ) is the time between photo detector output intensity changed from 90% to 10%. And fall time ( $T_f$ ) is the time between photo detector output intensity changed from 10% to 90%.

For additional information see FIG1.

**Note5. Definition of color chromaticity (CIE1931)**

CIE (x,y) chromaticity, The x,y value is determined by screen active area center position P5. For more information see FIG.2.

**Note6. Definition of viewing angle**

Viewing angle is the angle at which the contrast ratio is greater than 10. Angles are determined for the horizontal or x axis and the vertical or y axis with respect to the z axis which is normal to the LCD surface. For more information see FIG.3.

For viewing angle and response time testing, the testing data is base on Autronic-Melchers’ s ConoScope or DMS series Instruments or compatible.

**FIG.1. The definition of response Time**

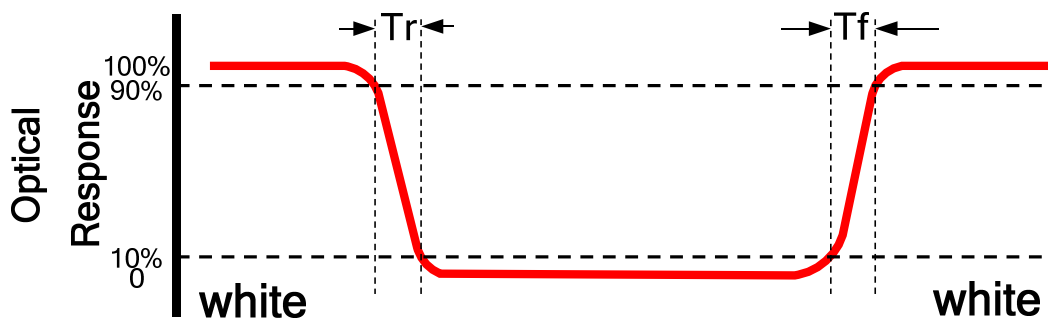

**FIG.2. Measuring method for contrast ratio, surface luminance,**

**luminance uniformity, CIE (x,y) chromaticity**

Size :  $S \leq 5"$  (see Figure a) A : 5 mm B : 5 mm

H,V : Active area

Light spot size  $\varnothing = 5\text{mm}$  (BM-5) or  $\varnothing = 7.7\text{mm}$  (BM-7) 50cm distance or compatible distance from the LCD surface to detector lens.

test spot position : see Figure a.

measurement instrument : TOPCON's luminance meter BM-5 or BM-7 or compatible (see Figure c).

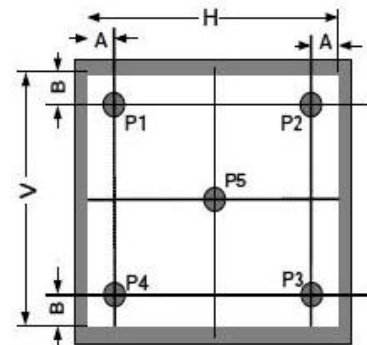

Figure a

Size :  $5'' < S \leq 12.3''$  (see Figure b) H,V : Active area

Light spot size  $\varnothing=5\text{mm}$  (BM-5) or  $\varnothing=7.7\text{mm}$  (BM-7) 50cm distance or compatible distance from the LCD surface to detector lens.

test spot position : see Figure b.

measurement instrument : TOPCON's luminance meter BM-5 or BM-7 or compatible (see Figure c).

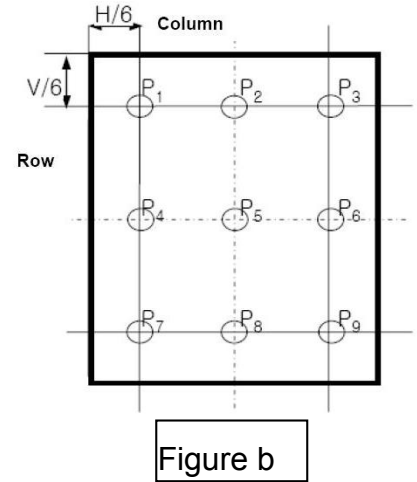
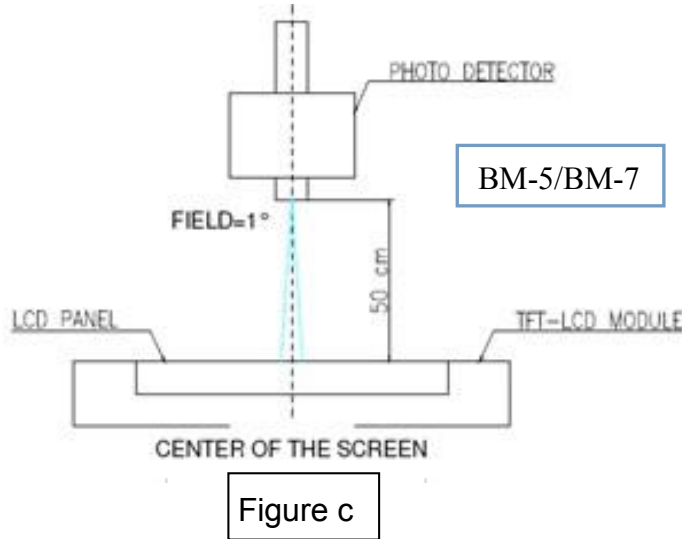
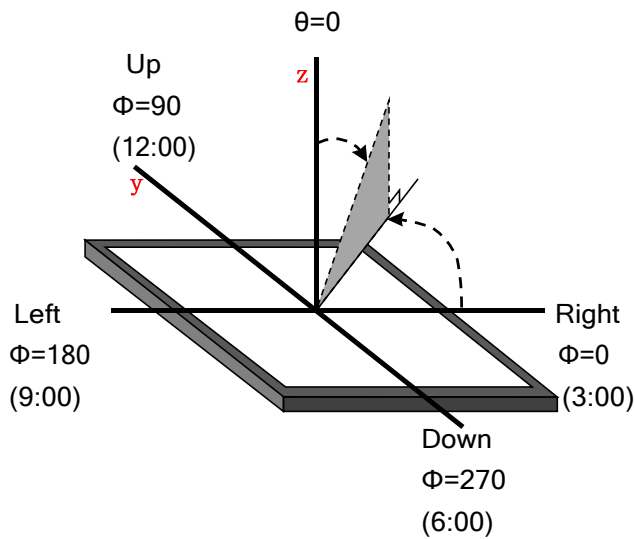

FIG.3.The definition of viewing angle



## 8. Environmental / Reliability Tests

No	Test Item	Condition	Remarks
1	High Temperature Operation	Ts= +70°C, 96hrs	Note 1 IEC60068-2-2, GB2423. 2-89
2	Low Temperature Operation	Ta= -20°C, 96hrs	Note 2 IEC60068-2-1 GB2423.1-89
3	High Temperature Storage	Ta= +80°C, 120hrs	IEC60068-2-2 GB2423. 2-89
4	Low Temperature Storage	Ta= -30°C, 120hrs	IEC60068-2-1 GB/T2423.1-89
5	High Temperature & Humidity Storage	Ta= +70°C, 90% RH max,120 hours	IEC60068-2-3 GB/T2423.3-2006
6	Thermal Shock (Non-operation)	-20°C 30 min ~ +70°C 30 min Change time: 5min, 30 Cycle	Start with cold temperature, end with high temperature IEC60068-2-14, GB2423.22-87
7	Electro Discharge (Operation)	Static C=150pF, R=330 Ω, 5 points/panel Air:±8KV, 5 times; Contact: ±4KV, 5 times; (Environment: 15°C ~ 35°C, 30% ~ 60%, 86Kpa ~ 106Kpa)	IEC61000-4-2 GB/T17626.2-1998
8	Vibration (Non-operation)	Frequency range: 10~55Hz, Stroke: 1.mm Sweep: 10Hz~55Hz~10Hz 2 hours for each direction of X .Y. Z. (package condition)	IEC60068-2-6 GB/T2423.5-1995
9	Shock (Non-operation)	60G 6ms, ± X, ±Y , ± Z 3 times for each direction	IEC60068-2-27 GB/T2423.5-1995
10	Package Drop Test	Height: 80 cm, 1 corner, 3 edges, 6 surfaces	IEC60068-2-32 GB/T2423.8-1995

Note: 1. Ts is the temperature of panel's surface.

2. Ta is the ambient temperature of sample.

3. The size of sample is 5pcs.



## 10. Packing

### Packing Method

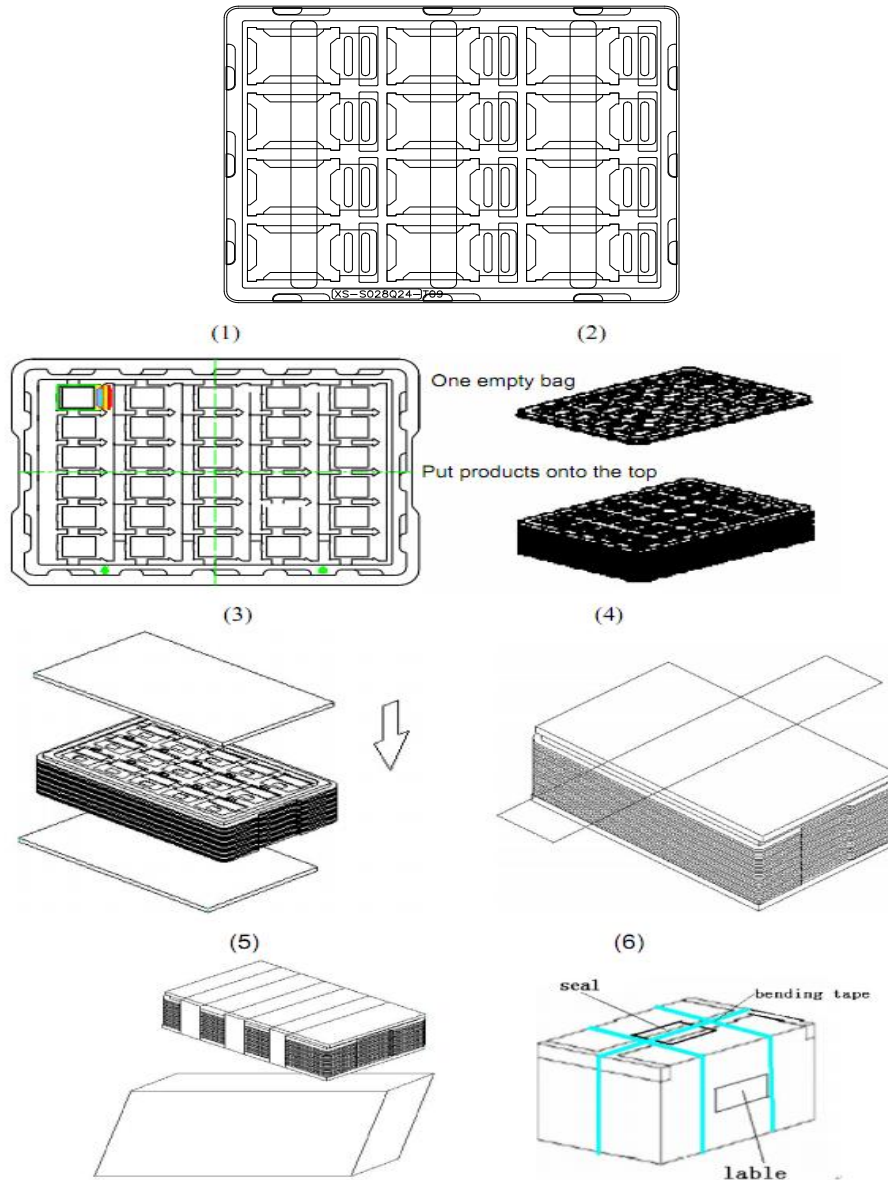

Steps:

1. Put module into tray cavity
2. Tray stacking
3. Put 1 cardboard under the tray stack and 1 cardboard above
4. Fix the cardboard to the tray stack with adhesive tape
5. Put the tray stack into carton
6. Carton sealing with adhesive tape

## 11. Precautions for Use of LCD modules

### 11.1 Handling Precautions

11.1.1. The display panel is made of glass. Do not subject it to a mechanical shock by dropping it from a high place, etc.

11.1.2. If the display panel is damaged and the liquid crystal substance inside it leaks out, be sure not to get any in your mouth, if the substance comes into contact with your skin or clothes, promptly wash it off using soap and water.

11.1.3. Do not apply excessive force to the display surface or the adjoining areas since this may cause the color tone to vary.

11.1.4. The polarizer covering the display surface of the LCD module is soft and easily scratched. Handle this polarizer carefully.

11.1.5. If the display surface is contaminated, breathe on the surface and gently wipe it with a soft dry cloth. If still not completely clear, moisten cloth with one of the following solvents:

- Isopropyl alcohol
- Ethyl alcohol

Solvents other than those mentioned above may damage the polarizer. Especially, do not use the following:

- Water
- Ketene
- Aromatic solvents

11.1.6. Do not attempt to disassemble the LCD Module.

11.1.7. If the logic circuit power is off, do not apply the input signals.

11.1.8. To prevent destruction of the elements by static electricity, be careful to maintain an optimum work environment.

11.1.8.1. Be sure to ground the body when handling the LCD Modules.

11.1.8.2. Tools required for assembly, such as soldering irons, must be properly ground.

11.1.8.3. To reduce the amount of static electricity generated, do not conduct assembly and other work under dry conditions.

11.1.8.4. The LCD Module is coated with a film to protect the display surface. Be care when peeling off this protective film since static electricity may be generated.

### 11.2 Storage Precautions

11.2.1. When storing the LCD modules, avoid exposure to direct sunlight or to the light of fluorescent lamps.

11.2.2. The LCD modules should be stored under the storage temperature range. If the LCD modules will be stored for a long time, the recommend condition is:

Temperature : 0°C ~ 40°C      Relatively humidity: ≤80%

11.2.3. The LCD modules should be stored in the room without acid, alkali and harmful gas.

### 12.3 Transportation Precautions

The LCD modules should be no falling and violent shocking during transportation, and also



# CDTech(H.K.)Electronics Limited

should avoid excessive press, water, damp and sunshine.