



# 深圳市思迪科科技有限公司

## SHENZHEN CDTECH ELECTRONICS

### Product Specification

<b>Model Name</b>	S039HWQ12HS
<b>Description</b>	Standard LCD Module 3.9" WQVGA 480(RGB)x128 Dots
<b>Date</b>	2021/5/27
<b>Version</b>	1.0

<b>Approved by/Date</b>	<b>Check by/Date</b>	<b>Prepared by/Date</b>
ZHP 2021/5/27	HL 2021/5/27	ZWF 2021/5/27

<b>Customer Approval</b>	
<b>Date</b>	



# 深圳市思迪科科技有限公司

## SHENZHEN CDTECH ELECTRONICS

### Table of Contents

1. Record of Revision .....	3
2. General Specifications .....	4
3. Input/Output Terminals .....	5
4. Absolute Maximum Rating .....	5
5. Electrical Characteristics .....	6
6. Interface Timing .....	8
7. Optical Characteristics .....	14
8. Environmental / Reliability Tests .....	18
9. Mechanical Drawing .....	20
10. Packing .....	21
11. Precautions for Use of LCD modules .....	22



# 深圳市思迪科科技有限公司

## SHENZHEN CDTECH ELECTRONICS

### 1. Record of Revision

Rev	Issued Date	Description	Editor
1.0	2021/5/27	First Release.	ZWF



# 深圳市思迪科科技有限公司

## SHENZHEN CDTECH ELECTRONICS

### 2. General Specifications

	Feature	Spec
Characteristics	Size	3.9 inch
	Resolution	480(horizontal)*128(Vertical)
	Interface	RGB-24bit
	Connect type	Connector
	Display Colors	16.7M
	Technology type	a-Si
	Pixel pitch (mm)	0.198*0.198
	Pixel Configuration	R.G.B-Stripe
	Display Mode	Normally Black
	LCD Driver IC	SC-7283-G4-1
	Viewing Direction	Full view
Mechanical	LCM (W x H x D) (mm)	105.50*40.64*2.95
	Active Area(mm)	95.04 x25.34
	Weight (g)	TBD
	LED Numbers	10 LEDs

Note 1: Requirements on Environmental Protection: RoHs

Note 2: LCM weight tolerance: +/- 5%

### 3. Input/Output Terminals

#### LCD PIN-MAP

No.	Symbol	Description
1	VBL-K	Backlight LED Cathode
2	VBL-A	Backlight LED Anode.
3	GND	Ground
4	VDD	Power supply
5~12	R0~R7	Data bus
13~20	G0~G7	Data bus
21~28	B0~B7	Data bus
29	GND	Ground
30	DCLK	Dot clock signal input. Latching input data at its rising edge.
31	DISP	Standby mode. Normally pulled high. DISP="1": Normally operation (Default) DISP="0": Timing controller, source driver will turn off ,all output are High-Z.
32	HSYNC	Horizontal sync input. Negative polarity.
33	VSYSN	Vertical sync input. Negative polarity..
34	DE	Data enable input. Active high to enable the input data bus under "DE Mode."
35	NC	No connect
36	GND	Ground
37	XR(NC)	The right side signal of TP
38	YD(NC)	The down side signal of TP
39	XL(NC)	The left side signal of TP
40	YU(NC)	The up side signal of TP

### 4. Absolute Maximum Rating

Item	Symbol	MIN	Typ	MAX	Unit	Remark
Supply Voltage	VDD	-0.5	-	5	V	-
Operating Temperature	TOPR	-20	-	70	°C	-
Storage Temperature	TSTG	-30	-	80	°C	-

### 5. Electrical Characteristics

#### 5.1 Driving TFT LCD Panel

Item	Symbol	MIN	TYP	MAX	Unit	Remark
Supply Voltage	VDD	3.0	3.3	3.6	V	
Input Signal Voltage	Low Level	V <sub>IL</sub>	GND	-	0.3x VDD	V
	High Level	V <sub>IH</sub>	0.7x VDD	-	VDD	V
Output Signal Voltage	Low Level	V <sub>IL</sub>	GND	-	VDD+0.4	V
	High Level	V <sub>IH</sub>	VDD-0.4	-	VDD	V
(Panel+LSI) Power Consumption	Black Mode (60Hz)	-	74		nW	
	Standby	-	50	-	uW	

#### 5.2 LED Driving Conditions

Item	Symbol	MIN	TYP	MAX	Unit	Remark
Forward Current	I <sub>F</sub>	-	40		mA	
Forward Voltage	V <sub>F</sub>	13.5		17	V	
Backlight Power consumption	W <sub>BL</sub>	0.54		0.68	W	
LED Lifetime		-	30000	-	Hrs	

Note 1: Each LED: I<sub>F</sub> =20 mA, V<sub>F</sub> =3.2+/-0.2V.

Note 2: Optical performance should be evaluated at Ta=25°C only.

Note 3: If LED is driven by high current, high ambient temperature & humidity condition. The life Time of LED will be reduced. Operating life means brightness goes down to 50% initial brightness. Typical operating life time is estimated data.

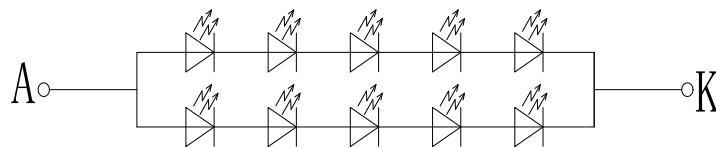
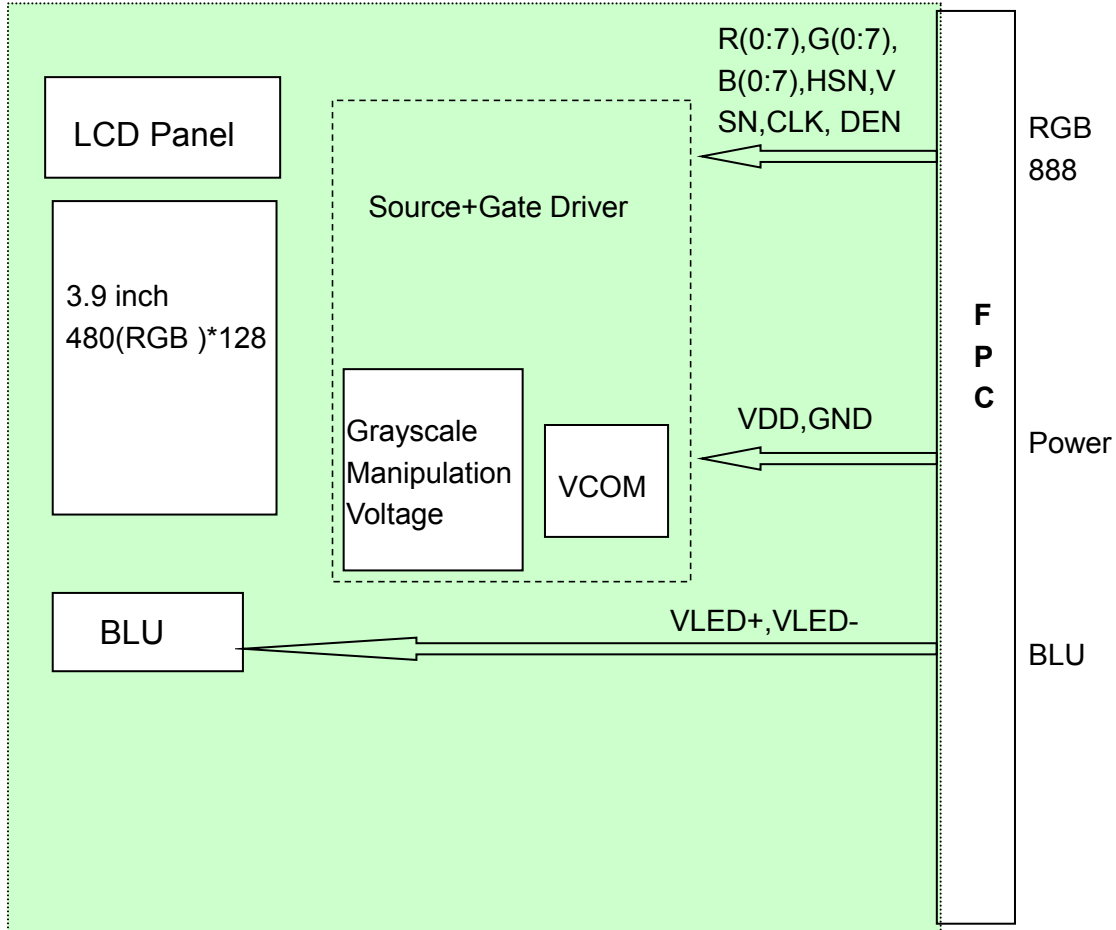

Figure: LED connection of backlight(Constant Current)

### 5.3 Block Diagram



## 6. Interface Timing

### 6.1 RGB Interface

#### 6.1.1 SYNC Mode

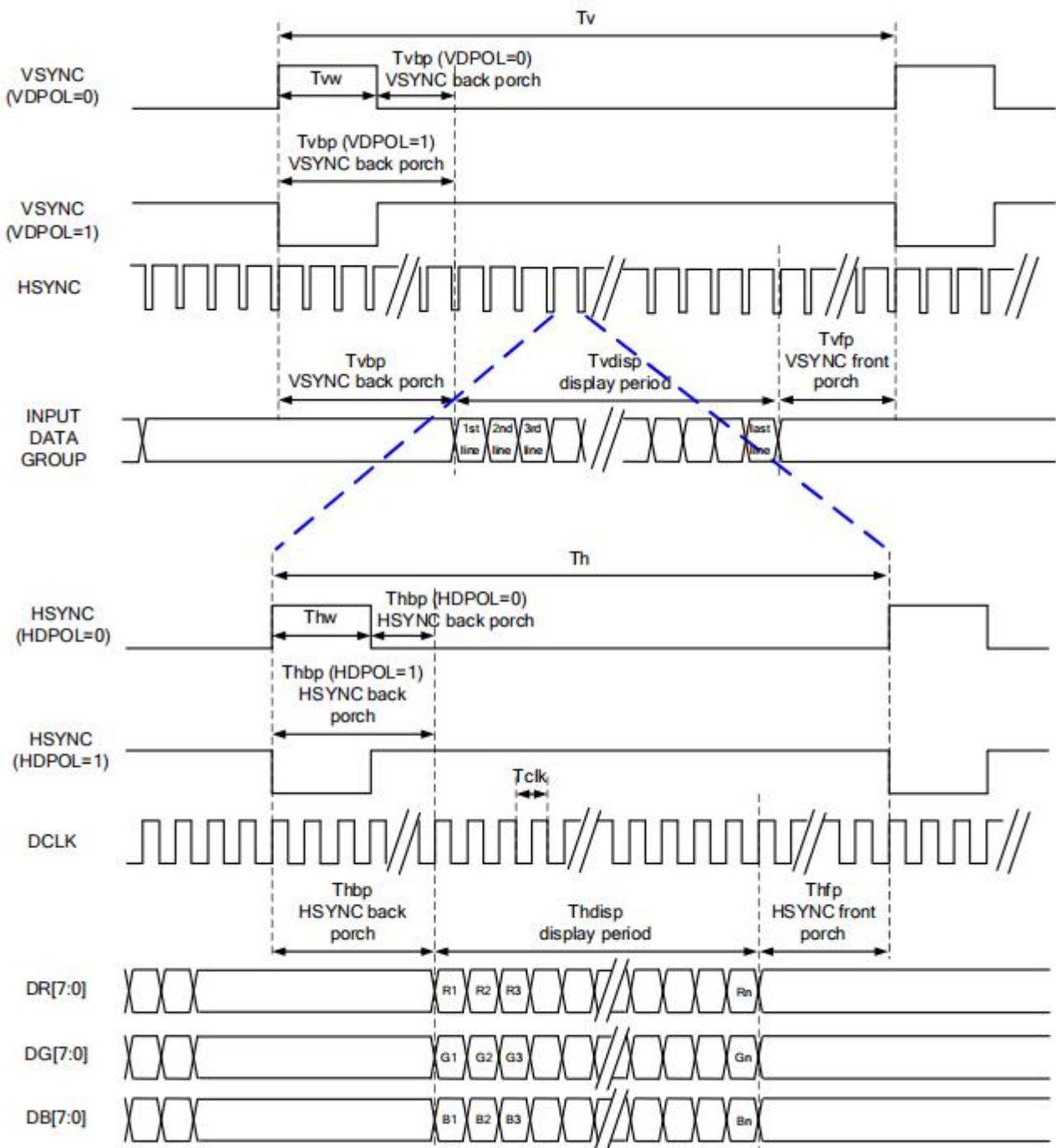



### 6.1. SYNC-DE Mode

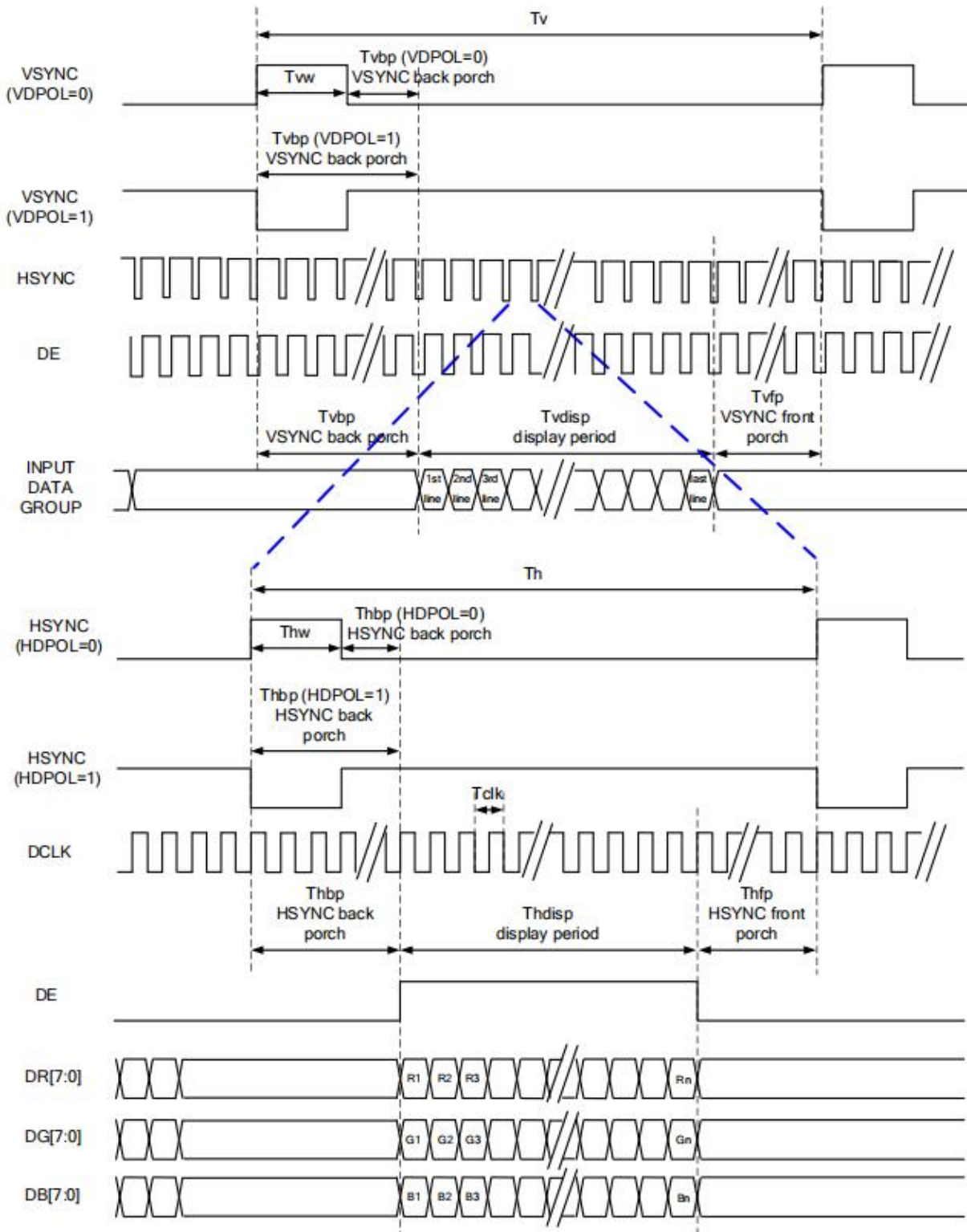

### 6.1.3 DE Mode

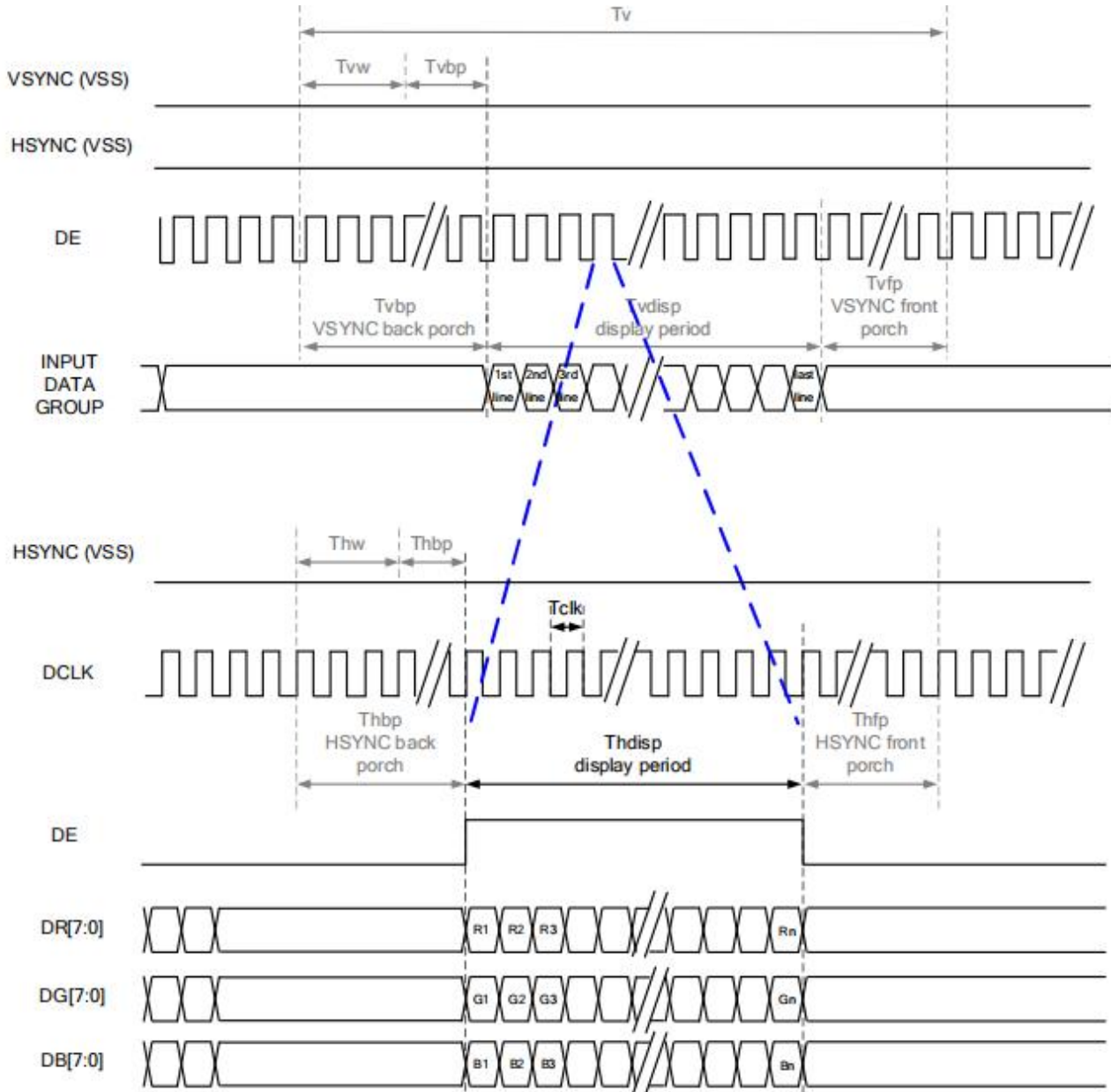

RGB Mode Selection Table	DCLK	HSYNC	VSYNC	DE
SYNC - DE Mode	Input	Input	Input	Input
SYNC Mode	Input	Input	Input	GND
DE Mode	Input	GND	GND	Input

Note: "Input" means these signals are driven by host side.

### 6.1.4 Parallel 24 bit RGB Input Timing Table

Parallel 24-bit RGB Input Timing (PVDD=VDD=VDDI= 3.3V, AGND= 0V, TA=25°C)

480RGB X 272 Resolution Timing Table							
Item	Symbol	Min.	Typ.	Max.	Unit	Remark	
DCLK Frequency	Fclk	8	9	12	MHz		
DCLK Period	Tclk	83	111	125	ns		
HSYNC	Period Time	Th	485	531	598	DCLK	
	Display Period	Thdisp		480		DCLK	
	Back Porch	Thbp	3	43	43	DCLK	By H_BLANKING setting
	Front Porch	Thfp	2	8	75	DCLK	
	Pulse Width	Thw	2	4	43	DCLK	
VSYNC	Period Time	Tv	276	292	321	HSYNC	
	Display Period	Tvdisp		272		HSYNC	
	Back Porch	Tvbp	2	12	12	HSYNC	By V_BLANKING setting
	Front Porch	Tvfp	2	8	37	HSYNC	
	Pulse Width	Tvw	2	4	12	HSYNC	

Note: It is necessary to keep Tvbp =12 and Thbp =43 in sync mode. DE mode is unnecessary to keep it.

### 6.1.5 Serial 8 bit RGB Input Timing Table

Serial 8-bit RGB Input Timing (PVDD=VDD=VDDI= 3.3V, AGND= 0V, TA=25°C)

480RGB X 272 Resolution Timing Table							
Item	Symbol	Min.	Typ.	Max.	Unit	Remark	
DCLK Frequency	Fclk	24	27	30	MHz		
DCLK Period	Tclk	33	37	42	ns		
HSYNC	Period Time	Th	1445	1491	1558	DCLK	
	Display Period	Thdisp		1440		DCLK	
	Back Porch	Thbp	3	43	43	DCLK	By H_BLANKING setting
	Front Porch	Thfp	2	8	75	DCLK	
	Pulse Width	Thw	2	4	43	DCLK	
VSYNC	Period Time	Tv	276	292	321	HSYNC	
	Display Period	Tvdisp		272		HSYNC	
	Back Porch	Tvbp	2	12	12	HSYNC	By V_BLANKING setting
	Front Porch	Tvfp	2	8	37	HSYNC	
	Pulse Width	Tvw	2	4	12	HSYNC	

Note: It is necessary to keep Tvbp =12 and Thbp =43 in sync mode. DE mode is unnecessary to keep it.

### 6.2 System Bus Timing for RGB Interface

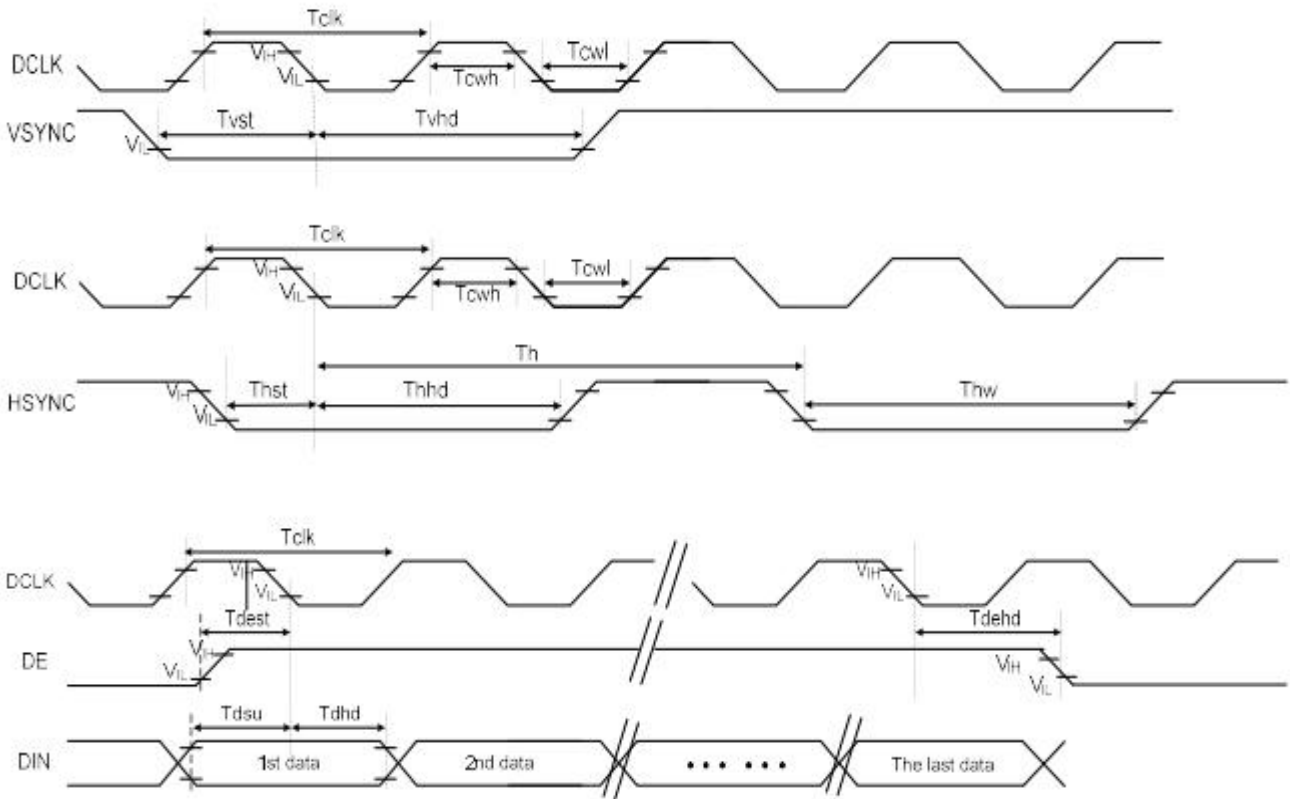

Item	Symbol	Min.	Typ.	Max.	Unit	Conditions
CLK Pulse Duty	$T_{cw}$	40	50	60	%	
HSYNC Width	$T_{hw}$	2	-	-	DCLK	
HSYNC Period	$T_h$	55	60	65	us	
VSYNC Setup Time	$T_{vst}$	12	-	-	ns	
VSYNC Hold Time	$T_{vhd}$	12	-	-	ns	
HSYNC Setup Time	$T_{hst}$	12	-	-	ns	
HSYNC Hold Time	$T_{hhd}$	12	-	-	ns	
Data Setup Time	$T_{dsu}$	12	-	-	ns	
Data Hold Time	$T_{dhhd}$	12	-	-	ns	
DE Setup Time	$T_{dst}$	12	-	-	ns	
DE Hold Time	$T_{dehd}$	12	-	-	ns	



## 7. Optical Characteristics

Items		Symbol	Condition	Min.	Typ.	Max.	Unit	Remark	Note
Response time		Tr+Tf	-	-	30	40	ms	FIG.1	Note4
Contrast Ratio		CR		600	800	-	-	FIG.2	Note1
Surface luminance		LV	$\theta = 0^\circ$	450	500	-	cd/m <sup>2</sup>	FIG.2	Note2
Luminance uniformity		Yu	$\theta = 0^\circ$	75	80	-	%	FIG.2	Note3
NTSC		-	$\theta = 0^\circ$	-	50	-	%	FIG.2	Note5
Viewing angle		$\theta_T$	Center CR $\geq$ 10	-	80	-	deg	FIG.3	Note6
		$\theta_B$		-	80	-	deg	FIG.3	
		$\theta_L$		-	80	-	deg	FIG.3	
		$\theta_R$		-	80	-	deg	FIG.3	
Chromaticity	Red	R <sub>X</sub>	$\theta = 0^\circ$ $\phi = 0^\circ$ Ta=25 $^\circ$	0.579	0.629	0.679	-	FIG.2 CIE1931	Note5
		R <sub>Y</sub>		0.276	0.326	0.376	-		
	Green	G <sub>X</sub>		0.287	0.337	0.387	-		
		G <sub>Y</sub>		0.536	0.586	0.636	-		
	Blue	B <sub>X</sub>		0.086	0.136	0.186	-		
		B <sub>Y</sub>		0.093	0.143	0.193	-		
	White	W <sub>X</sub>		0.260	0.310	0.360	-		
		W <sub>Y</sub>		0.290	0.340	0.390	-		



# 深圳市思迪科科技有限公司

## SHENZHEN CDTECH ELECTRONICS

### Note1. Definition of contrast ratio

Contrast ratio(Cr) is defined mathematically by the following formula. For more information see FIG.2.

$$\text{Contrast ratio} = \frac{\text{Luminance measured when LCD on the "White" state}}{\text{Luminance measured when LCD on the "Black" state}}$$

For contrast ratio, Surface Luminance, Luminance uniformity and CIE, the testing data is based on TOPCON's BM-5 or BM-7 photo detector or compatible.

### Note2. Definition of surface luminance.

Surface luminance is the luminance with all pixels displaying white. For more information see FIG.2.

$L_v$  = Average Surface Luminance with all white pixels ( $P_1, P_2, P_3, \dots, P_n$ )

### Note3. Definition of luminance uniformity

The luminance uniformity in surface luminance is determined by measuring luminance at each test position 1 through n, and then dividing the maximum luminance of n points luminance by minimum luminance of n points luminance. For more information see FIG.2.

$$YU = \frac{\text{Minimum surface luminance with all white pixels (} P_1, P_2, P_3, \dots, P_n \text{)}}{\text{Maximum surface luminance with all white pixels (} P_1, P_2, P_3, \dots, P_n \text{)}}$$

### Note4. Definition of response time

The response time is defined as the LCD optical switching time interval between "White" state and "Black" state. Rise time ( $T_r$ ) is the time between photo detector output intensity changed from 90% to 10%. And fall time ( $T_f$ ) is the time between photo detector output intensity changed from 10% to 90%.

For additional information see FIG1.

### Note5. Definition of color chromaticity (CIE1931)

CIE (x,y) chromaticity, The x,y value is determined by screen active area center position P5. For more information see FIG.2.

### Note6. Definition of viewing angle

Viewing angle is the angle at which the contrast ratio is greater than 10. Angles are determined for the horizontal or x axis and the vertical or y axis with respect to the z axis which is normal to the LCD surface. For more information see FIG.3.

For viewing angle and response time testing, the testing data is based on Autronic-Melchers' s ConoScope or DMS series Instruments or compatible.

FIG.1.The definition of response Time

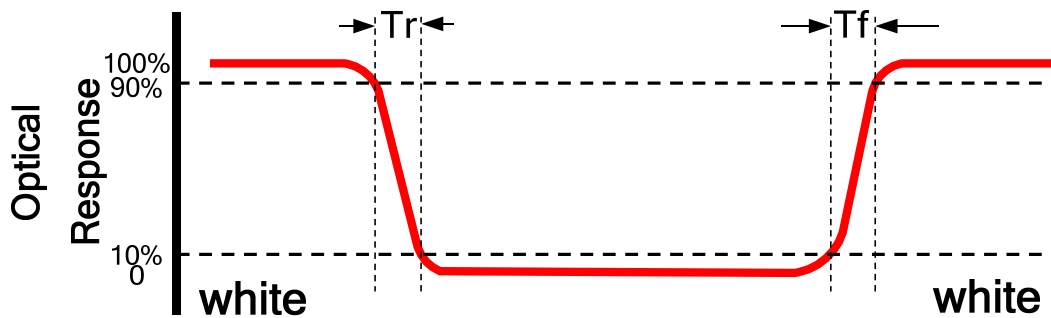

FIG.2. Measuring method for contrast ratio, surface luminance, luminance uniformity, CIE (x,y) chromaticity

Size :  $S \leq 5''$  (see Figure a) A : 5 mm B : 5 mm  
H,V : Active area

Light spot size  $\varnothing = 5\text{mm}$  (BM-5) or  $\varnothing = 7.7\text{mm}$  (BM-7) 50cm distance or compatible distance from the LCD surface to detector lens.

test spot position : see Figure a.

measurement instrument : TOPCON's luminance meter BM-5 or BM-7 or compatible (see Figure c).

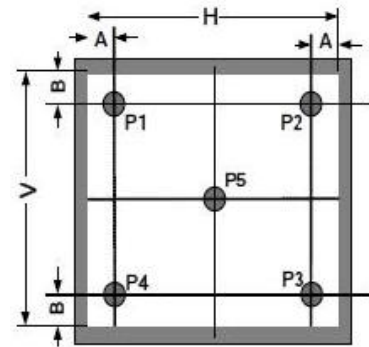

Figure a

Size :  $5'' < S \leq 12.3''$  (see Figure b) H,V : Active area

Light spot size  $\varnothing = 5\text{mm}$  (BM-5) or  $\varnothing = 7.7\text{mm}$  (BM-7) 50cm distance or compatible distance from the LCD surface to detector lens.

test spot position : see Figure b.

measurement instrument : TOPCON's luminance meter BM-5 or BM-7 or compatible (see Figure c).

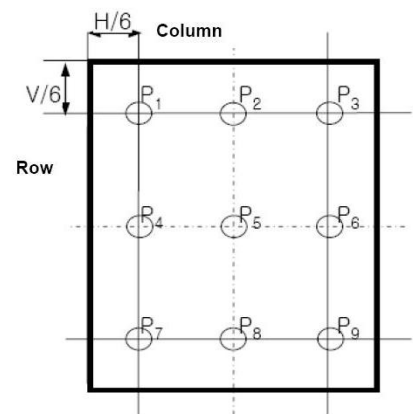

Figure b

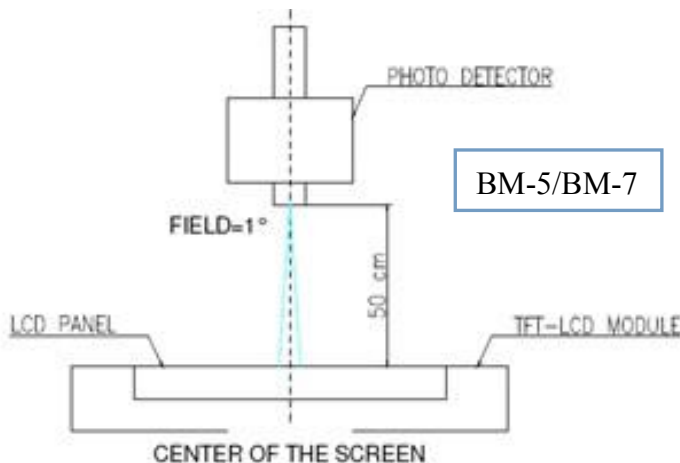
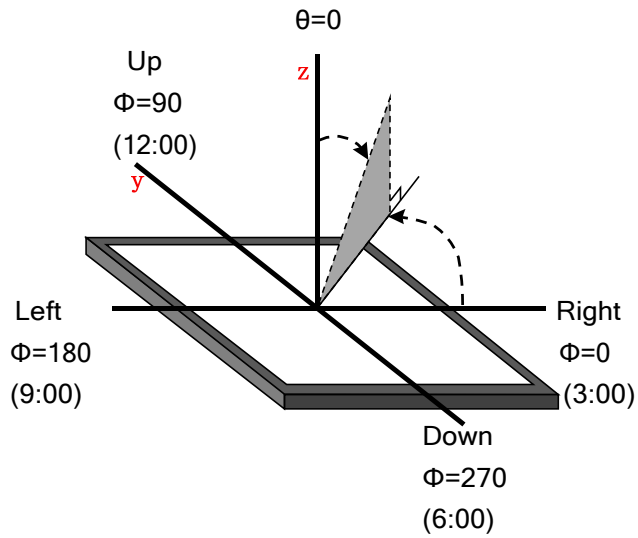



Figure c

FIG.3.The definition of viewing angle



## 8. Environmental / Reliability Tests

No	Test Item	Condition	Remarks
1	High Temperature Operation	Ts= +70°C, 96hrs	IEC60068-2-1:2007 GB2423. 2-2008
2	Low Temperature Operation	Ta= -20°C, 96hrs	IEC60068-2-1:2007 GB2423.1-2008
3	High Temperature Storage	Ta= +80°C, 96hrs	IEC60068-2-1:2007 GB2423. 2-2008
4	Low Temperature Storage	Ta= -30°C, 96hrs	IEC60068-2-1:2007 GB2423.1-2008
5	High Temperature & Humidity Operation	Ta= +60°C, 90% RH max, 96 hours	IIEC60068-2-78:2001 GB/T2423.3-2006
6	Thermal Shock (Non-operation)	-30°C 30 min ~ +80°C 30 min Change time: 5min, 20 Cycle	Start with cold temperature, end with high temperature IEC60068-2-14:1984, GB2423.22-2002
7	ESD	C=150pF, R=330 Ω, 5 points/panel , Air:±8KV, 5 times Contact: ±4KV, 5 times (Environment: 15°C ~ 35°C, 30% ~ 60%, 86Kpa ~ 106Kpa)	IEC61000-4-2:2001 GB/T17626.2-2006
8	Vibration (Non-operation)	Frequency range: 10~55Hz, Stroke: 1.5mm , Sweep: 10Hz~55Hz~10Hz 2 hours for each direction of X .Y. Z. (6 hours for total)	IEC60068-2-6:1982 GB/T2423.10-1995
9	Mechanical Shock (Non-operation)	Half Sine Wave 60G ,6ms,±X,±Y,±Z 3times for each direction	IEC60068-2-27:1987 GB/T2423.5—1995
10	Package Drop Test	Height: 60 cm, 1 corner, 3 edges, 6 surfaces	IEC60068-2-32:1990 GB/T2423.8-1995

Notes:



# 深圳市思迪科科技有限公司

## SHENZHEN CDTECH ELECTRONICS

1. The test result shall be evaluated after the sample has been left at room temperature and humidity for 2 hours without load. No condensation shall be accepted. The sample will not be accepted if appear these defects:

- 1).Air bubble in the LCD;
  - 2).Seal leak
  - 3).Non-display
  - 4).missing segments
  - 5).Glass crack
  - 6).CR reduction >40%
  - 7).IDD increase >100%
  - 8).Brightness reduction >50%
  - 9).Color coordinate tolerance >0.05
- 2.≤7.0 inch: The size of sample is 5pcs;  
>7.0 inch: The size of sample is 2pcs;
3. One test sample must complete each test item;
- 4.In case of malfunction defect caused by ESD damage, if it would be recovered to normal state after resetting, it would be judge as a good part.
- 5.In the test of High Temperature Operation and High Temperature & Humidity Operation ,the operation temperature is the surface temperature of module.

### 9. Mechanical Drawing

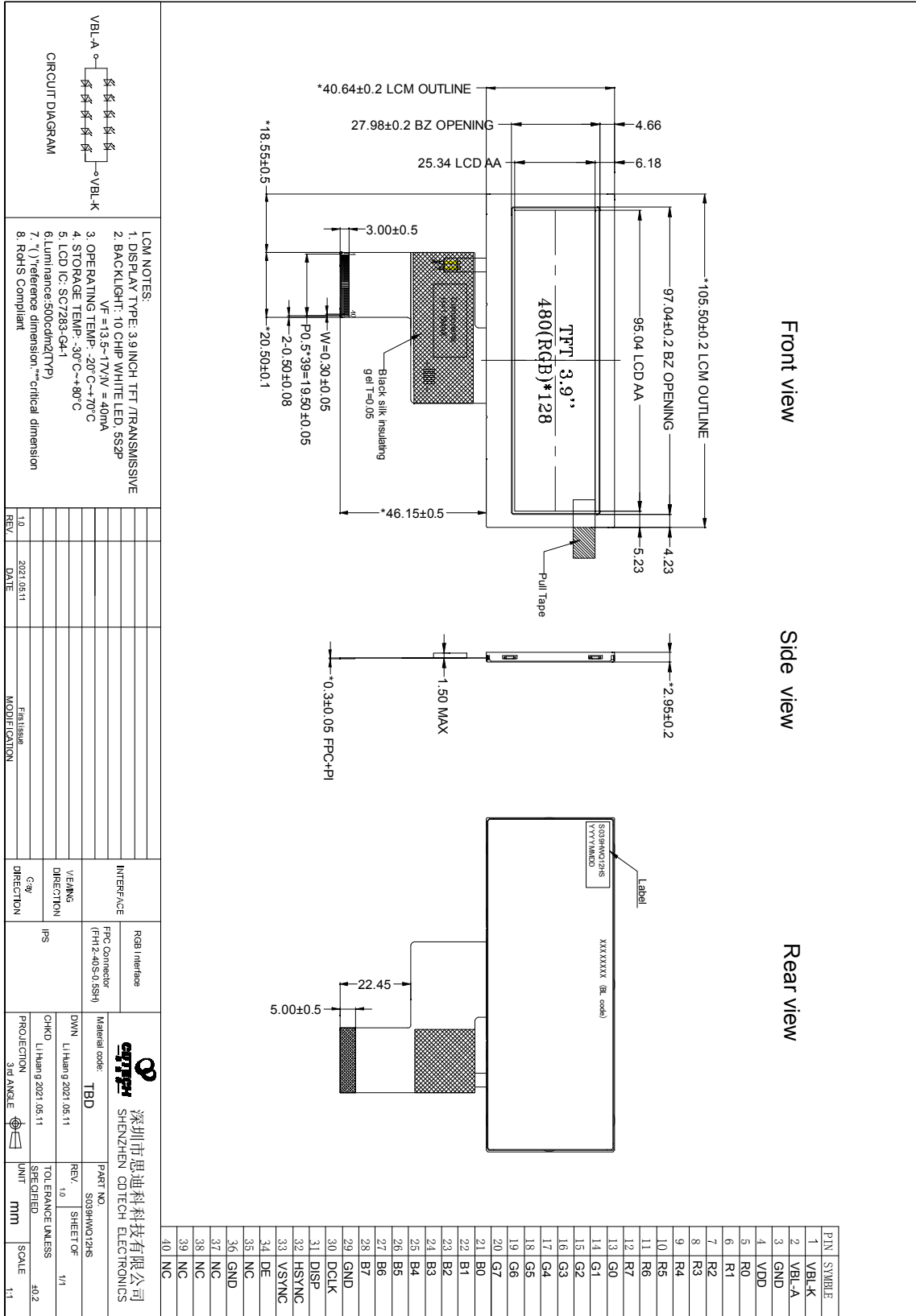

### 10. Packing

#### Packing Method

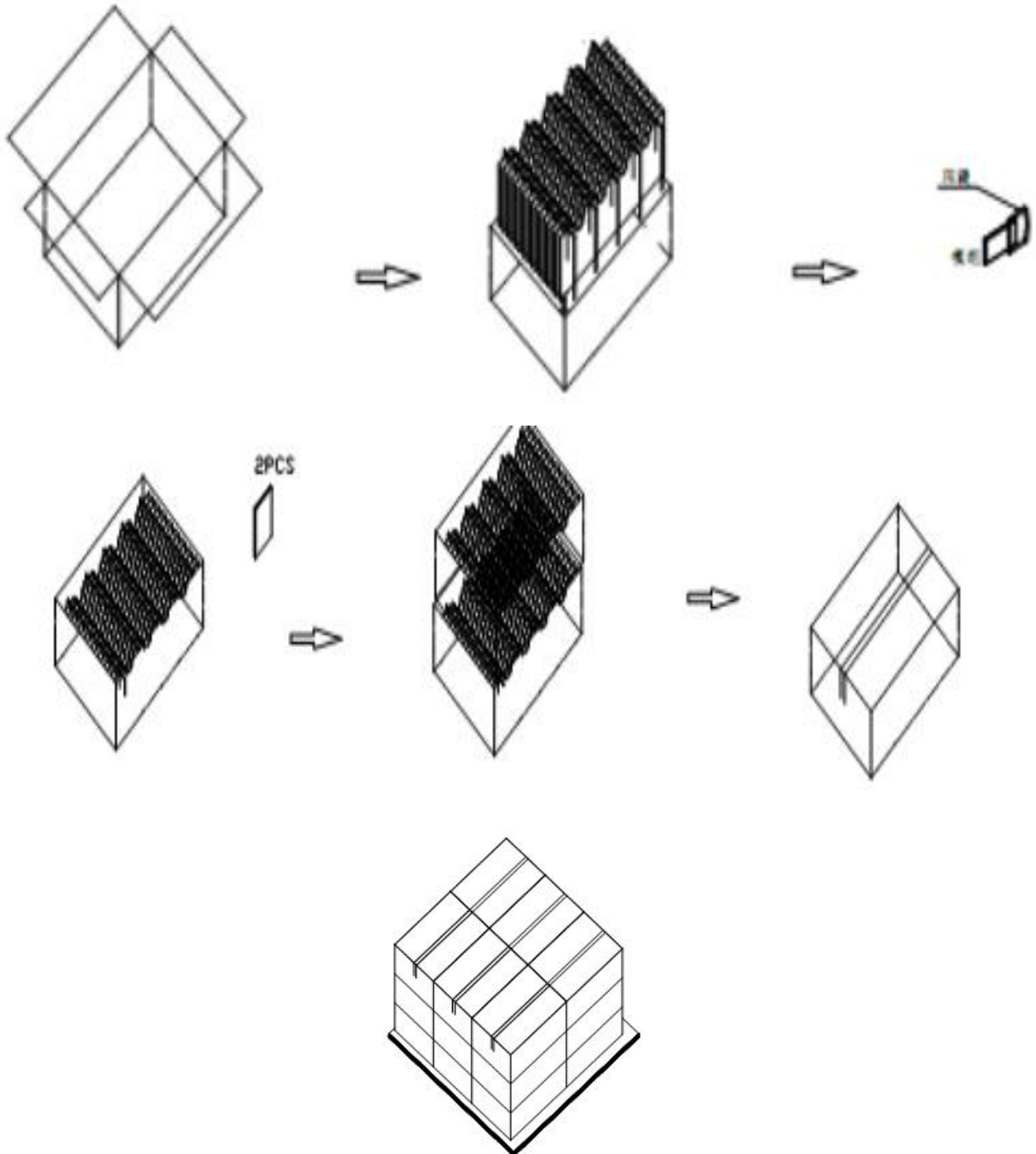

## 11. Precautions for Use of LCD modules

### 11.1 Handling Precautions

11.1.1. The display panel is made of glass. Do not subject it to a mechanical shock by dropping it from a high place, etc.

11.1.2. If the display panel is damaged and the liquid crystal substance inside it leaks out, be sure not to get any in your mouth, if the substance comes into contact with your skin or clothes, promptly wash it off using soap and water.

11.1.3. Do not apply excessive force to the display surface or the adjoining areas since this may cause the color tone to vary.

11.1.4. The polarizer covering the display surface of the LCD module is soft and easily scratched. Handle this polarizer carefully.

11.1.5. If the display surface is contaminated, breathe on the surface and gently wipe it with a soft dry cloth. If still not completely clear, moisten cloth with one of the following solvents:

- Isopropyl alcohol
- Ethyl alcohol

Solvents other than those mentioned above may damage the polarizer. Especially, do not use the following:

- Water
- Ketene
- Aromatic solvents

11.1.6. Do not attempt to disassemble the LCD Module.

11.1.7. If the logic circuit power is off, do not apply the input signals.

11.1.8. To prevent destruction of the elements by static electricity, be careful to maintain an optimum work environment.

11.1.8.1. Be sure to ground the body when handling the LCD Modules.

11.1.8.2. Tools required for assembly, such as soldering irons, must be properly ground.

11.1.8.3. To reduce the amount of static electricity generated, do not conduct assembly and other work under dry conditions.

11.1.8.4. The LCD Module is coated with a film to protect the display surface. Be care when peeling off this protective film since static electricity may be generated.

### 11.2 Storage Precautions

11.2.1. When storing the LCD modules, avoid exposure to direct sunlight or to the light of fluorescent lamps.

11.2.2. The LCD modules should be stored under the storage temperature range. If the LCD modules will be stored for a long time, the recommend condition is:

Temperature : 0°C ~ 40°C      Relatively humidity: ≤80%

11.2.3. The LCD modules should be stored in the room without acid, alkali and harmful gas.



# 深圳市思迪科科技有限公司

## SHENZHEN CDTECH ELECTRONICS

### **11.3 Transportation Precautions**

The LCD modules should be no falling and violent shocking during transportation, and also should avoid excessive press, water, damp and sunshine.